

Wenzhou LEEYEE Electric Co., Ltd.

Add : Dagang Industrial Zone, Beibaixiang, Yueqing, Zhejiang, China

Service Hotline : 4008267118

Sales Hotline : +86-577-62967776

Fax : +86-577-62986088



Solemnly declare that:

- This manual is printed by Shanghai leiyue Electric Co., Ltd. and is only used to explain the information related to some products.
- Relevant contents of this manual will be improved at any time due to technical upgrading or new production process without notice.
- Please feel free to contact us when ordering to confirm relevant information.
- Reproduction in whole or in part is prohibited without permission.
- Continuous product research and development, continuous technological innovation.

SURGE PROTECTIVE DEVICE

Products Selection Manual



Waterproof



Lightning Protection



Dustproof

Safe and reliable lightning protection device
Provide comprehensive protection





Company Profile

Wenzhou Leeyee Electric is a professional manufacturer, which specialized in lightning protection products research and design, manufacture and sale. Over the ten years since company establish, with the principle of seeking development by technology, creating brand with quality, push the lightning protection technology development continuously. Our products are widely used in buildings, power, communication, petrochemical industry, railway, military project, PV system, Car charging pile, power distribution equipment, automation control etc. areas, sells all over the world.

Company insist the purpose of 'Quality first, Customer first, Service first, Reputation first, introduce international advanced technology, took the lead of gaining ISO in lightning protection area. All items are PICC guarantee.

Our hot sell items including power supply surge protective device, signal surge protective device, PV surge protective device, lightning protection box, Photovoltaic combiner box, lightning rod etc. and very glad to supply all the best to customers overseas.



LEEYEE®

雷悦电气



2.0

Shop Fabrication



- Mould Independent Research and Development
- Plastic parts, metal parts stamping integration
- SPD lightning impact test stand complete
- Got CE certificate
- OEM ODM service supply





→ Every process of our products is accurate during production. We require that every product meet the national quality inspection standards. We have the strength to reassure our customers...



3.0

Production Equipment

→ Have powerful production machines
Design and manufacturing capabilities of automated assembly equipment...



Quality service

→ To provide customers with the products they need - and to have excellent service, we value each customer. Even if it's just to buy a small product. When mistakes are made, learn from them, not make excuses for the customer.



Integrity cooperation



24-hour maintenance hotline



Technical service hotline



Quality warranty 36 months







Product Contents



LY1-D20/1(S) Pluggable Single-Pole SPD	01
LY1-D20/2(S) Pluggable Single-Pole SPD	03
LY1-D20/3(S) Pluggable Multi-Pole SPD	05
LY1-D20/4(S) Pluggable Multi-Pole SPD	07
LY1-D20/1(S)+1 Pluggable Single-Pole SPD	09
LY1-D20/3(S)+1 Pluggable Multi-Pole SPD	11
LY1-C40/1(S) Pluggable Single-Pole SPD	13
LY1-C40/2(S) Pluggable Single-Pole SPD	15
LY1-C40/3(S) Pluggable Multi-Pole SPD	17
LY1-C40/4(S) Pluggable Multi-Pole SPD	19
LY1-C40/1(S)+1 Pluggable Single-Pole SPD	21
LY1-C40/3(S)+1 Pluggable Multi-Pole SPD	23
LY1-C40PV/2(S) 600V Pluggable Single-Pole SPD	25
LY1-C40PV/3(S) 600V Pluggable Multi-Pole SPD	27
LY1-C40PV/2(S) 1000V Pluggable Multi-Pole SPD	29
LY1-C40PV/3(S) 1000V Pluggable Multi-Pole SPD	31
LY1-C40PV/3(S) 1000V(D4) Pluggable Multi-Pole SPD	33
LY1-C40PV/3(S) 1500V(D4) Pluggable Multi-Pole SPD	35
LY1-D20M/2(S) Pluggable Single-Pole SPD	37
LY1-D20M/4(S) Pluggable Multi-Pole SPD	39
LY1-D20M/1(S)+1 Pluggable Single-Pole SPD	41
LY1-D20M/3(S)+1 Pluggable Multi-Pole SPD	43
LY1-C40M/2(S) Pluggable Single-Pole SPD	45
LY1-C40M/4(S) Pluggable Multi-Pole SPD	47
LY1-C40M/1(S)+1 Pluggable Single-Pole SPD	49
LY1-C40M/3(S)+1 Pluggable Multi-Pole SPD	51
LY1-B65/1(S) Pluggable Single-Pole SPD	53
LY1-B65/2(S) Pluggable Single-Pole SPD	55
LY1-B65/3(S) Pluggable Multi-Pole SPD	57
LY1-B65/4(S) Pluggable Multi-Pole SPD	59
LY1-B65/1(S)+1 Pluggable Single-Pole SPD	61
LY1-B65/3(S)+1 Pluggable Multi-Pole SPD	63

LY1-B80/1(S) Pluggable Single-Pole SPD	65
LY1-B80/2(S) Pluggable Single-Pole SPD	67
LY1-B80/3(S) Pluggable Multi-Pole SPD	69
LY1-B80/4(S) Pluggable Multi-Pole SPD	71
LY1-B80/1(S)+1 Pluggable Single-Pole SPD	73
LY1-B80/3(S)+1 Pluggable Multi-Pole SPD	75
LY1-12.5/1(S) Pluggable Single-Pole SPD	77
LY1-12.5/2(S) Pluggable Single-Pole SPD	79
LY1-12.5/3(S) Pluggable Multi-Pole SPD	81
LY1-12.5/4(S) Pluggable Multi-Pole SPD	83
LY1-12.5/1(S)+1 Pluggable Single-Pole SPD	85
LY1-12.5/3(S)+1 Pluggable Multi-Pole SPD	87
LY1-B25/1(S) Monoblock Single-Pole SPD	89
LY1-B25/2(S) Monoblock Multi-Pole SPD	91
LY1-B25/3(S) Monoblock Multi-Pole SPD	93
LY1-B25/4(S) Monoblock Multi-Pole SPD	95
LY1-B25/1(S)+1 Monoblock Multi-Pole SPD	97
LY1-B25/2(S)+1 Monoblock Multi-Pole SPD	99
LY1-B25/3(S)+1 Monoblock Multi-Pole SPD	101
LYB-12.5/275 Pluggable Multi-Pole SPD	103
LYSCB SPD back-up protector	105
LY10 Data signal/DC surge protective device	107
LY11 RS232 surge protective device	109
LY21-1 RJ11 telephone surge protective device	110
LY21-2 RJ45 network surge protective device(POE)	111
LY21-2 RJ45 network surge protective device	112
LY23 BNC video surge protective device	114
LYX LYX CCTV surge protective device/Camera surge protective device	117
LY26-XF Explosion-proof waterproof series potential connector	119
LY-PVX Photovoltaic combiner box	120
LY30-Z Lightning rod	121
LY-J,3M Lightning counter	123
LY-ZJ Intelligent lightning counter	124
LY-ZFC Intelligent lightning detection module	125
LY Varistor	126

LY1-D20/1(S) Pluggable Single-Pole SPD



Class II • Class III • Type 2 • Type 3

Location of Use: Sub-Distribution Boards
 Mode of Protection: L-PE, N-PE
 Surge Ratings: $I_n = 10 \text{ kA}$ (8/20 μs)
 IEC/EN/UL Category: Class II+III / Type 2+3
 Protective Elements: High Energy MOV
 Housing: Pluggable Design
 Compliance: IEC 61643-11:2011
 EN 61643-11:2012

■ Technical Data

IEC Electrical		75	150	275	320	385	440
Nominal AC Voltage (50/60Hz)	U_o / U_n	60 V	120 V	230 V	230 V	230 V	400 V
Maximum Continuous Operating Voltage (AC)	U_c	75 V	150 V	275V	320 V	385 V	440 V
Nominal Discharge Current (8/20 μs)	I_n	10 kA	10 kA	10 kA	10 kA	10 kA	10 kA
Maximum Discharge Current (8/20 μs)	I_{max}	20 kA	20 kA	20 kA	20 kA	20 kA	20 kA
Voltage Protection Level	U_p	0.2 kV	0.6 kV	1.3 kV	1.5 kV	1.5 kV	1.8 kV
Response Time	t_A	< 25 ns					
Back-Up Fuse (max)		125 A gL / gG					
Short-Circuit Current Rating (AC)	I_{SCCR}	10 kA					
TOV Withstand 5s	U_T	90V	180V	335V	335V	335V	580V
TOV 120min	U_T	115V	230V	440V	440V	440V	765V
	mode	Withstand	Withstand	Safe Fail	Safe Fail	Safe Fail	Safe Fail
Mechanical & Environmental							
Operating Temperature Range	T_a	-40°F to +158°F [-40°C to +70°C]					
Permissible Operating Humidity	RH	5%...95%					
Atmospheric pressure and altitude		80k Pa ... 106k Pa / -500 m.....2000 m					
Terminal Screw Torque	M_{max}	39.9 lbf-in [4.5 Nm]					
Conductor Cross Section (max)		2 AWG (Solid, Stranded) / 4 AWG (Flexible) 35 mm ² (Solid, Stranded) / 25 mm ² (Flexible)					
Mounting		35 mm DIN Rail, EN 60715					
Degree of Protection		IP 20 (built-in)					
Housing Material		Thermoplastic: Extinguishing Degree UL 94 V-0					
Thermal Protection		Yes					
Operating State / Fault Indication		Green ok / Red defect					
Remote Contacts (RC)		Optional					
RC Switching Capacity		AC: 250V / 0.5 A; DC: 250V / 0.1 A;125V / 0.2 A;75V / 0.5 A					
RC Conductor Cross Section (max)		16 AWG (Solid) / 1.5 mm ² (Solid)					

LY1-D20/1(S)

Pluggable Single-Pole SPD



Internal Configuration

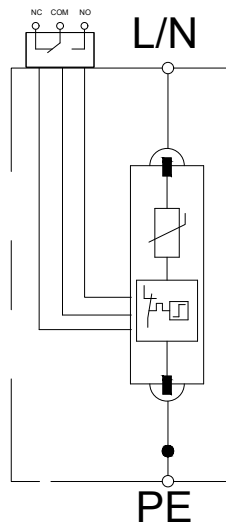

Dimensions & Packaging

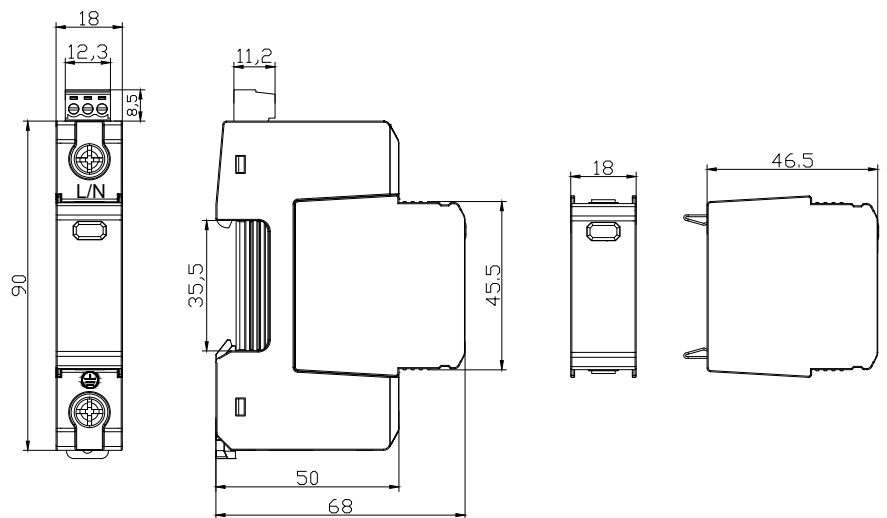

Connection Diagram

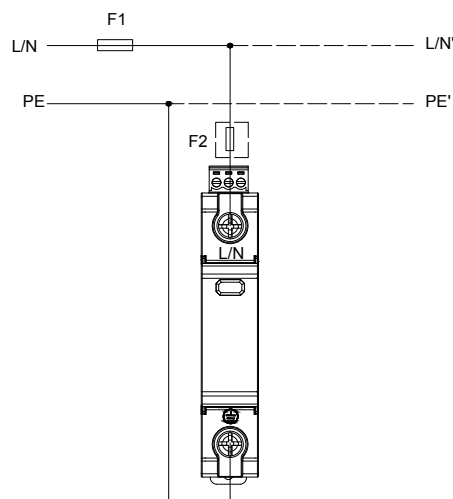

LY1-D20/2(S)

Pluggable Single-Pole SPD



Class II • Class III • Type 2 • Type 3

Location of Use: Sub-Distribution Boards
 Mode of Protection: L-PE, N-PE
 Surge Ratings: $I_n = 10 \text{ kA}$ (8/20 μs)
 IEC/EN/UL Category: Class II+III / Type 2+3
 Protective Elements: High Energy MOV
 Housing: Pluggable Design
 Compliance: IEC 61643-11:2011
 EN 61643-11:2012

■ Technical Data

IEC Electrical		75	150	275	320	385	440
Nominal AC Voltage (50/60Hz)	U_o / U_n	60 V	120 V	230 V	230 V	230 V	400 V
Maximum Continuous Operating Voltage (AC)	U_c	75 V	150 V	275V	320 V	385 V	440 V
Nominal Discharge Current (8/20 μs)	I_n	10 kA	10 kA	10 kA	10 kA	10 kA	10 kA
Maximum Discharge Current (8/20 μs)	I_{max}	20 kA	20 kA	20 kA	20 kA	20 kA	20 kA
Voltage Protection Level	U_p	0.2 kV	0.6 kV	1.3 kV	1.5 kV	1.5 kV	1.8 kV
Response Time	t_A	< 25 ns					
Back-Up Fuse (max)		125 A gL / gG					
Short-Circuit Current Rating (AC)	I_{SCCR}	10 kA					
TOV Withstand 5s	U_T	90V	180V	335V	335V	335V	580V
TOV 120min	U_T	115V	230V	440V	440V	440V	765V
	mode	Withstand	Withstand	Safe Fail	Safe Fail	Safe Fail	Safe Fail
Mechanical & Environmental							
Operating Temperature Range	T_a	-40°F to +158°F [-40°C to +70°C]					
Permissible Operating Humidity	RH	5%...95%					
Atmospheric pressure and altitude		80k Pa ... 106k Pa / -500 m.....2000 m					
Terminal Screw Torque	M_{max}	39.9 lbf-in [4.5 Nm]					
Conductor Cross Section (max)		2 AWG (Solid, Stranded) / 4 AWG (Flexible) 35 mm ² (Solid, Stranded) / 25 mm ² (Flexible)					
Mounting		35 mm DIN Rail, EN 60715					
Degree of Protection		IP 20 (built-in)					
Housing Material		Thermoplastic: Extinguishing Degree UL 94 V-0					
Thermal Protection		Yes					
Operating State / Fault Indication		Green ok / Red defect					
Remote Contacts (RC)		Optional					
RC Switching Capacity		AC: 250V / 0.5 A; DC: 250V / 0.1 A;125V / 0.2 A;75V / 0.5 A					
RC Conductor Cross Section (max)		16 AWG (Solid) / 1.5 mm ² (Solid)					

LY1-D20/2(S)

Pluggable Single-Pole SPD



Internal Configuration

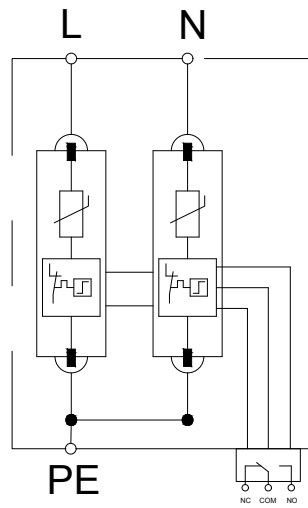

Dimensions & Packaging

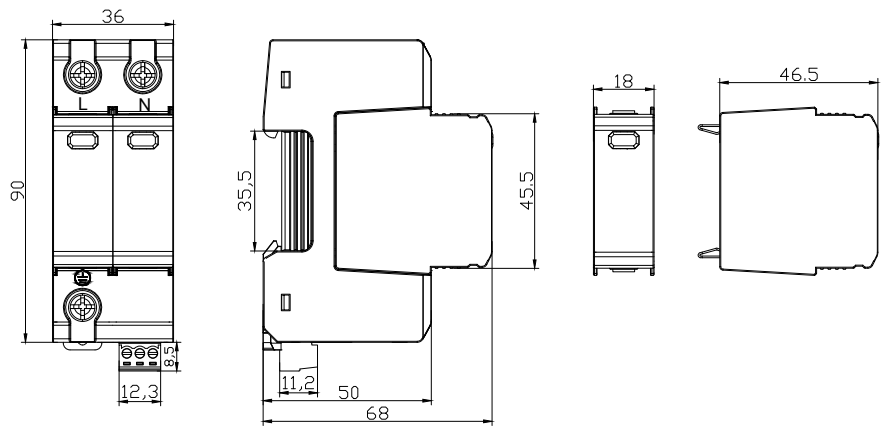

Connection Diagram

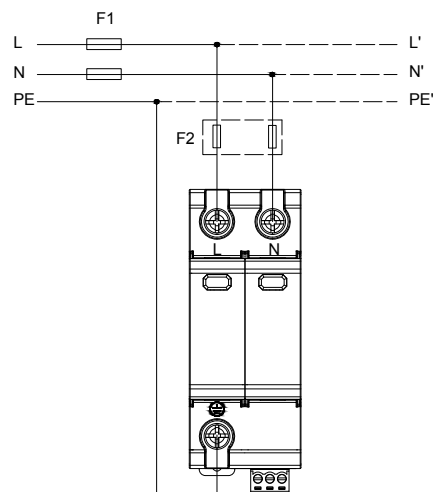

LY1-D20/3(S) Pluggable Multi-Pole SPD



Class II • Class III • Type 2 • Type 3

Location of Use: Sub-Distribution Boards

Mode of Protection: L-PE, N-PE

Surge Ratings: $I_n = 10 \text{ kA}$ (8/20 μs)

IEC/EN/UL Category: Class II / Type 2 / Type 1CA

Protective Elements: High Energy MOV

Housing: Pluggable Design

Compliance: IEC 61643-11:2011

EN 61643-11:2012

■ Technical Data

IEC Electrical		150	275	320	385	440
Nominal AC Voltage (50/60Hz)	U_o / U_n	120 V	230 V	230 V	230 V	400 V
Maximum Continuous Operating Voltage (AC)	U_c	150 V	275V	320 V	385 V	440 V
Nominal Discharge Current (8/20 μs)	I_n	10 kA	10 kA	10 kA	10 kA	10 kA
Maximum Discharge Current (8/20 μs)	I_{max}	20 kA	20 kA	20 kA	20 kA	20 kA
Voltage Protection Level	U_p	0.6 kV	1.3 kV	1.5 kV	1.5 kV	1.8 kV
Response Time	t_A	< 25 ns				
Back-Up Fuse (max)		125 A gL / gG				
Short-Circuit Current Rating (AC)	I_{SCCR}	10 kA				
TOV Withstand 5s	U_T	180V	335V	335V	335V	580V
TOV 120min	U_T	230V	440V	440V	440V	765V
	mode	Withstand	Safe Fail	Safe Fail	Safe Fail	Safe Fail
Mechanical & Environmental						
Operating Temperature Range	T_a	-40°F to +158°F [-40°C to +70°C]				
Permissible Operating Humidity	RH	5%...95%				
Atmospheric pressure and altitude		80k Pa ... 106k Pa / -500 m.....2000 m				
Terminal Screw Torque	M_{max}	39.9 lbf-in [4.5 Nm]				
Conductor Cross Section (max)		2 AWG (Solid, Stranded) / 4 AWG (Flexible)				
		35 mm ² (Solid, Stranded) / 25 mm ² (Flexible)				
Mounting		35 mm DIN Rail, EN 60715				
Degree of Protection		IP 20 (built-in)				
Housing Material		Thermoplastic: Extinguishing Degree UL 94 V-0				
Thermal Protection		Yes				
Operating State / Fault Indication		Green ok / Red defect				
Remote Contacts (RC)		Optional				
RC Switching Capacity		AC: 250V / 0.5 A; DC: 250V / 0.1 A;125V / 0.2 A;75V / 0.5 A				
RC Conductor Cross Section (max)		16 AWG (Solid) / 1.5 mm ² (Solid)				

LY1-D20/3(S)

Pluggable Multi-Pole SPD



Internal Configuration

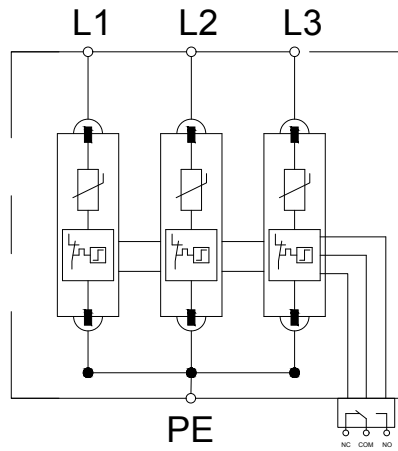

Dimensions & Packaging

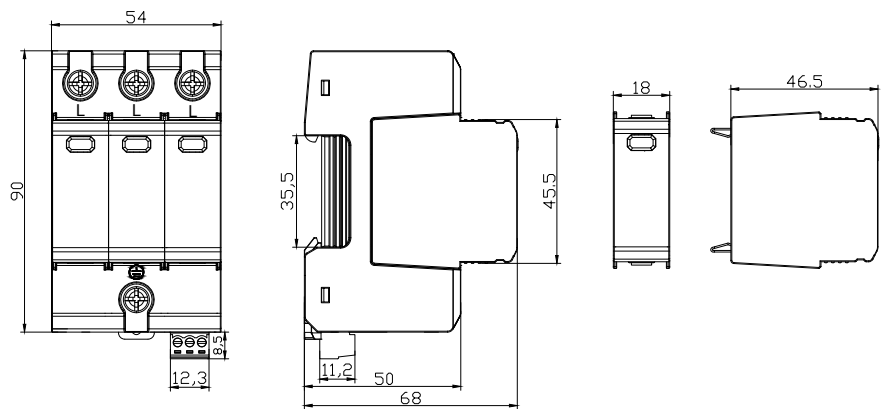

Connection Diagram

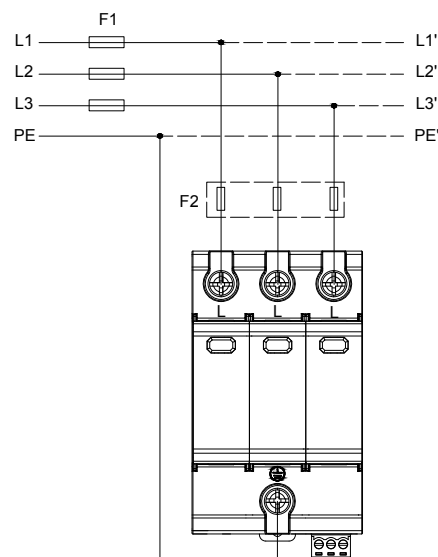

LY1-D20/4(S) Pluggable Multi-Pole SPD



Class II • Class III • Type 2 • Type 3

Location of Use: Sub-Distribution Boards
 Mode of Protection: L-PE, N-PE
 Surge Ratings: $I_n = 10 \text{ kA}$ (8/20 μs)
 IEC/EN/UL Category: Class II+III / Type 2+3
 Protective Elements: High Energy MOV
 Housing: Pluggable Design
 Compliance: IEC 61643-11:2011
 EN 61643-11:2012

■ Technical Data

IEC Electrical		150	275	320	385	440
Nominal AC Voltage (50/60Hz)	U_o / U_n	120 V	230 V	230 V	230 V	400 V
Maximum Continuous Operating Voltage (AC)	U_c	150 V	275V	320 V	385 V	440 V
Nominal Discharge Current (8/20 μs)	I_n	10 kA	10 kA	10 kA	10 kA	10 kA
Maximum Discharge Current (8/20 μs)	I_{max}	20 kA	20 kA	20 kA	20 kA	20 kA
Voltage Protection Level	U_p	0.6 kV	1.3 kV	1.5 kV	1.5 kV	1.8 kV
Response Time	t_A	< 25 ns				
Back-Up Fuse (max)		125 A gL / gG				
Short-Circuit Current Rating (AC)	I_{SCCR}	10 kA				
TOV Withstand 5s	U_T	180V	335V	335V	335V	580V
TOV 120min	U_T	230V	440V	440V	440V	765V
	mode	Withstand	Safe Fail	Safe Fail	Safe Fail	Safe Fail
Mechanical & Environmental						
Operating Temperature Range	T_a	-40°F to +158°F [-40°C to +70°C]				
Permissible Operating Humidity	RH	5%...95%				
Atmospheric pressure and altitude		80k Pa ... 106k Pa / -500 m.....2000 m				
Terminal Screw Torque	M_{max}	39.9 lbf-in [4.5 Nm]				
Conductor Cross Section (max)		2 AWG (Solid, Stranded) / 4 AWG (Flexible) 35 mm ² (Solid, Stranded) / 25 mm ² (Flexible)				
Mounting		35 mm DIN Rail, EN 60715				
Degree of Protection		IP 20 (built-in)				
Housing Material		Thermoplastic: Extinguishing Degree UL 94 V-0				
Thermal Protection		Yes				
Operating State / Fault Indication		Green ok / Red defect				
Remote Contacts (RC)		Optional				
RC Switching Capacity		AC: 250V / 0.5 A; DC: 250V / 0.1 A;125V / 0.2 A;75V / 0.5 A				
RC Conductor Cross Section (max)		16 AWG (Solid) / 1.5 mm ² (Solid)				

LY1-D20/4(S)

Pluggable Multi-Pole SPD



Internal Configuration

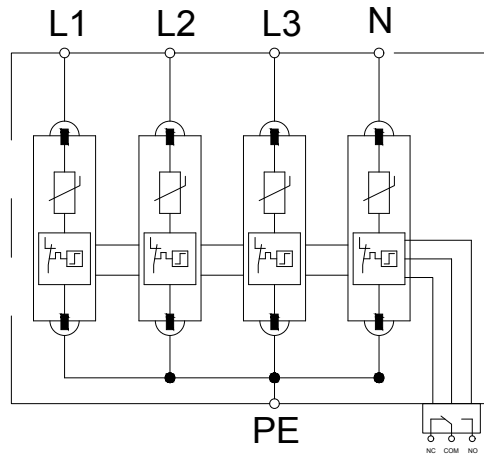

Dimensions & Packaging

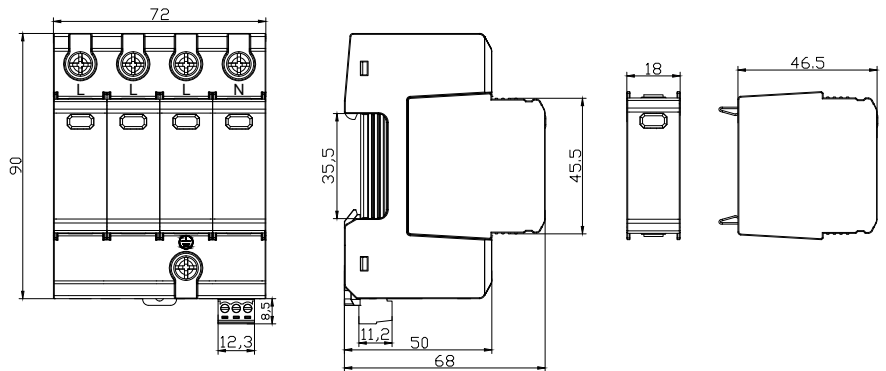

Connection Diagram

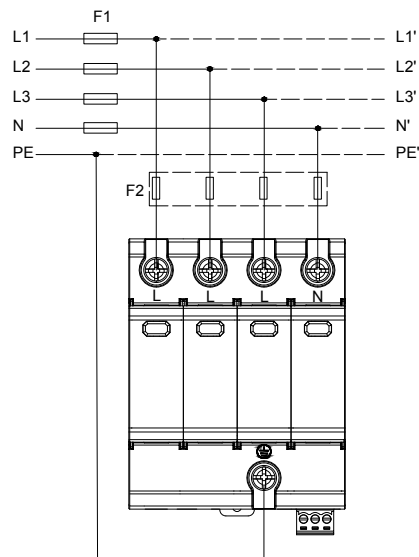

LY1-D20/1(S)+1 Pluggable Single-Pole SPD



Class II • Class III • Type 2 • Type 3

Location of Use: Sub-Distribution Boards

Mode of Protection: L-N, N-PE

Surge Ratings: $I_n = 10 \text{ kA}$ (8/20 μs)

IEC/EN/UL Category: Class II+III / Type 2+3

Protective Elements: High Energy MOV and GDT

Housing: Pluggable Design

Compliance: IEC 61643-11:2011

EN 61643-11:2012

■ Technical Data

IEC Electrical		75	150	275	320	385	440
Nominal AC Voltage (50/60Hz)		60 V	120 V	230 V	230 V	230 V	400 V
Maximum Continuous Operating Voltage (AC)	(L-N) U_c	75 V	150 V	275V	320 V	385 V	440 V
	(N-PE) U_c	255V					
Nominal Discharge Current (8/20 μs)	(L-N) / (N-PE) I_n	10kV / 10kA					
Maximum Discharge Current (8/20 μs)	(L-N) / (N-PE) I_{max}	20 kA / 20 kA					
Voltage Protection Level	(L-N) / (N-PE) U_p	0.2kV/1.5kV	0.6kV/1.5kV	1.3kV/1.5kV	1.5kV/1.5kV	1.5kV/1.5kV	1.8kV/1.5kV
Follow Current Interrupt Rating	(N-PE) I_{fi}	100A _{RMS}					
Response Time	(L-N) / (N-PE) t_A	< 25 ns / < 100 ns					
Back-Up Fuse (max)		125 A gL / gG					
Short-Circuit Current Rating (AC)	(L-N) I_{SCCR}	10 kA					
TOV Withstand 5s	(L-N) U_T	90V	180V	335V	335V	335V	580V
TOV 120min	(L-N) U_T	115V	230V	440V	440V	440V	765V
		mode	Withstand	Withstand	Safe Fail	Safe Fail	Safe Fail
TOV Withstand 200ms	(N-PE) U_T	1200V					
Mechanical & Environmental							
Operating Temperature Range	T_a	-40°F to +158°F [-40°C to +70°C]					
Permissible Operating Humidity	RH	5%...95%					
Atmospheric pressure and altitude		80k Pa ... 106k Pa / -500 m.....2000 m					
Terminal Screw Torque	M_{max}	39.9 lbf-in [4.5 Nm]					
Conductor Cross Section (max)		2 AWG (Solid, Stranded) / 4 AWG (Flexible)					
		35 mm ² (Solid, Stranded) / 25 mm ² (Flexible)					
Mounting		35 mm DIN Rail, EN 60715					
Degree of Protection		IP 20 (built-in)					
Housing Material		Thermoplastic: Extinguishing Degree UL 94 V-0					
Thermal Protection		Yes					
Operating State / Fault Indication		Green ok / Red defect					
Remote Contacts (RC)		Optional					
RC Switching Capacity		AC: 250V / 0.5 A; DC: 250V / 0.1 A; 125 V / 0.2 A; 75 V / 0.5 A					
RC Conductor Cross Section (max)		16 AWG (Solid) / 1.5 mm ² (Solid)					

LY1-D20/1(S)+1

Pluggable Single-Pole SPD



Internal Configuration

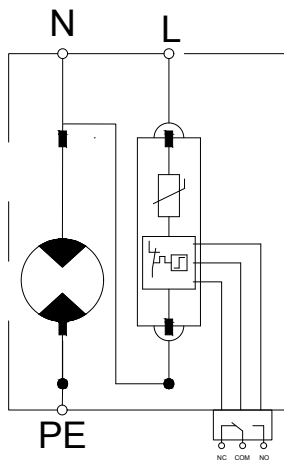

Dimensions & Packaging

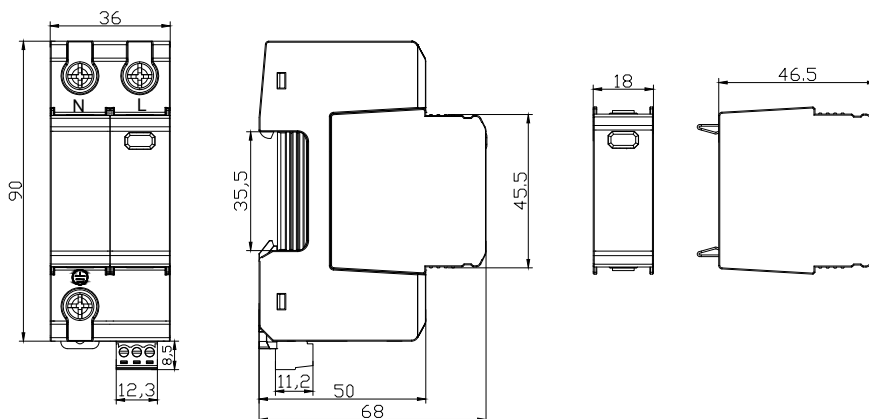

Connection Diagram

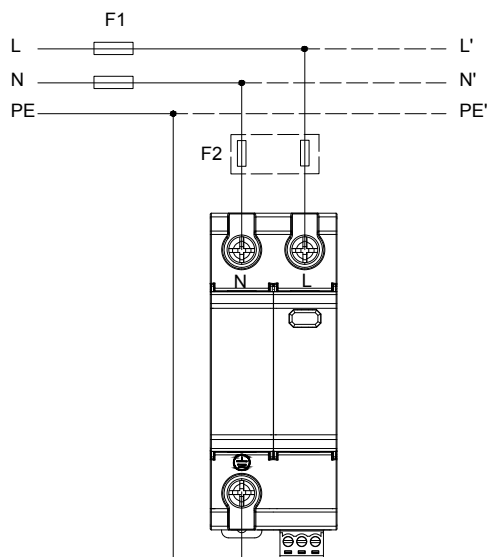

LY1-D20/3(S)+1 Pluggable Multi-Pole SPD



Class II • Class III • Type 2 • Type 3

Location of Use: Sub-Distribution Boards

Mode of Protection: L-N, N-PE

Surge Ratings: $I_n = 10 \text{ kA}$ (8/20 μs)

IEC/EN/UL Category: Class II+III / Type 2+3

Protective Elements: High Energy MOV and GDT

Housing: Pluggable Design

Compliance: IEC 61643-11:2011

EN 61643-11:2012

■ Technical Data

IEC Electrical		150	275	320	385	440
Nominal AC Voltage (50/60Hz)		120 V	230 V	230 V	230 V	400 V
Maximum Continuous Operating Voltage (AC)	(L-N) U_c	150 V	275V	320 V	385 V	440 V
	(N-PE) U_c			255V		
Nominal Discharge Current (8/20 μs)	(L-N) / (N-PE) I_n			10 kA / 10kA		
Maximum Discharge Current (8/20 μs)	(L-N) / (N-PE) I_{max}			20 kA / 20 kA		
Voltage Protection Level	(L-N) / (N-PE) U_p	0.6kV/1.5kV	1.3kV/1.5kV	1.5kV/1.5kV	1.5kV/1.5kV	1.8kV/1.5kV
Follow Current Interrupt Rating	(N-PE) I_{fi}			100A _{RMS}		
Response Time	(L-N) / (N-PE) t_A			< 25 ns / < 100 ns		
Back-Up Fuse (max)				125 A gL / gG		
Short-Circuit Current Rating (AC)	(L-N) I_{SCCR}			10 kA		
TOV Withstand 5s	(L-N) U_T	180V	335V	335V	335V	580V
TOV 120min	(L-N) U_T	230V	440V	440V	440V	765V
	mode	Withstand	Safe Fail	Safe Fail	Safe Fail	Safe Fail
TOV Withstand 200ms	(N-PE) U_T			1200V		
Mechanical & Environmental						
Operating Temperature Range	T_a	-40°F to +158°F [-40°C to +70°C]				
Permissible Operating Humidity	RH	5%...95%				
Atmospheric pressure and altitude		80k Pa ... 106k Pa / -500 m.....2000 m				
Terminal Screw Torque	M_{max}	39.9 lbf-in [4.5 Nm]				
Conductor Cross Section (max)		2 AWG (Solid, Stranded) / 4 AWG (Flexible)				
		35 mm ² (Solid, Stranded) / 25 mm ² (Flexible)				
Mounting		35 mm DIN Rail, EN 60715				
Degree of Protection		IP 20 (built-in)				
Housing Material		Thermoplastic: Extinguishing Degree UL 94 V-0				
Thermal Protection		Yes				
Operating State / Fault Indication		Green ok / Red defect				
Remote Contacts (RC)		Optional				
RC Switching Capacity		AC: 250V / 0.5 A; DC: 250V / 0.1 A; 125 V / 0.2 A; 75 V / 0.5 A				
RC Conductor Cross Section (max)		16 AWG (Solid) / 1.5 mm ² (Solid)				

LY1-D20/3(S)+1

Pluggable Multi-Pole SPD



Internal Configuration

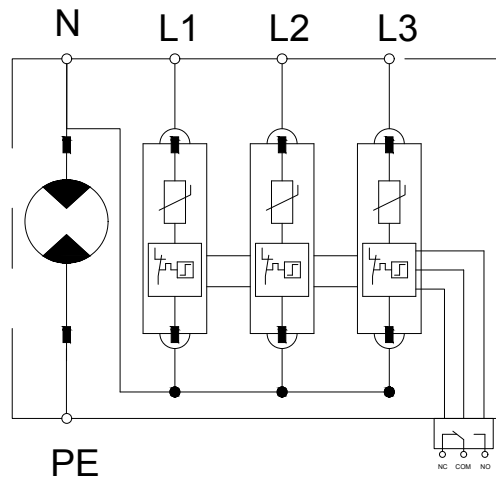

Dimensions & Packaging

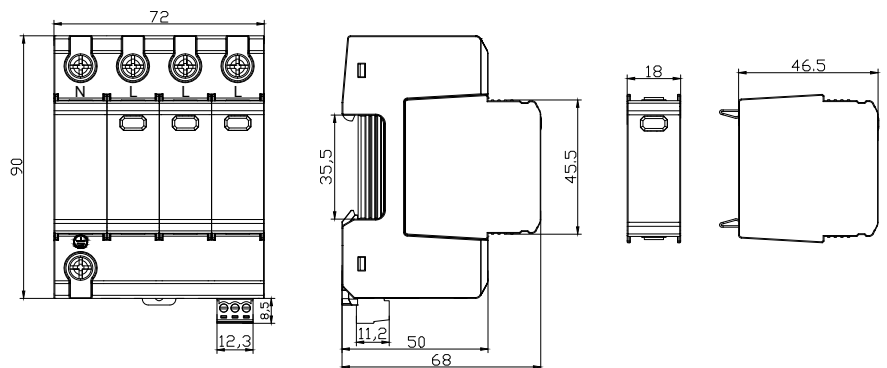

Connection Diagram

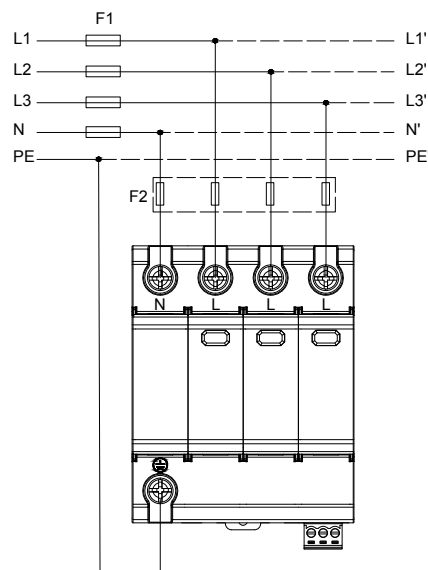

LY1-C40/1(S) Pluggable Single-Pole SPD



Class II • Type 2 • Type 1CA

Location of Use: Sub-Distribution Boards
 Mode of Protection: L-PE, N-PE
 Surge Ratings: $I_n = 20 \text{ kA}$ (8/20 μs)
 IEC/EN/UL Category: Class II / Type 2 / Type 1CA
 Protective Elements: High Energy MOV
 Housing: Pluggable Design
 Compliance: IEC 61643-11:2011
 EN 61643-11:2012

■ Technical Data

IEC Electrical		75	150	275	320	385	440
Nominal AC Voltage (50/60Hz)	U_o / U_n	60 V	120 V	230 V	230 V	230 V	400 V
Maximum Continuous Operating Voltage (AC)	U_c	75 V	150 V	275V	320 V	385 V	440 V
Nominal Discharge Current (8/20 μs)	I_n	20 kA	20 kA	20 kA	20 kA	20 kA	20 kA
Maximum Discharge Current (8/20 μs)	I_{max}	40 kA	40 kA	40 kA	40 kA	40 kA	40 kA
Voltage Protection Level	U_p	0.4 kV	1 kV	11.5 kV	1.6 kV	1.8 kV	2 kV
Impulse Current (10/350 μs) I_{imp} (L-N)		7kA					
Response Time	t_A	< 25 ns					
Back-Up Fuse (max)		125 A gL / gG					
Short-Circuit Current Rating (AC)	I_{SCCR}	25 kA / 50 kA					
TOV Withstand 5s	U_T	90V	180V	335V	335V	335V	580V
TOV 120min	U_T	115V	230V	440V	440V	440V	765V
	mode	Withstand	Withstand	Safe Fail	Safe Fail	Safe Fail	Safe Fail
Mechanical & Environmental							
Operating Temperature Range	T_a	-40°F to +158°F [-40°C to +70°C]					
Permissible Operating Humidity	RH	5%...95%					
Atmospheric pressure and altitude		80k Pa ... 106k Pa / -500 m.....2000 m					
Terminal Screw Torque	M_{max}	39.9 lbf·in [4.5 Nm]					
Conductor Cross Section (max)		2 AWG (Solid, Stranded) / 4 AWG (Flexible) 35 mm ² (Solid, Stranded) / 25 mm ² (Flexible)					
Mounting		35 mm DIN Rail, EN 60715					
Degree of Protection		IP 20 (built-in)					
Housing Material		Thermoplastic: Extinguishing Degree UL 94 V-0					
Thermal Protection		Yes					
Operating State / Fault Indication		Green ok / Red defect					
Remote Contacts (RC)		Optional					
RC Switching Capacity		AC: 250V / 0.5 A; DC: 250V / 0.1 A; 125V / 0.2 A; 75V / 0.5 A					
RC Conductor Cross Section (max)		16 AWG (Solid) / 1.5 mm ² (Solid)					

LY1-C40/1(S)

Pluggable Single-Pole SPD



Internal Configuration

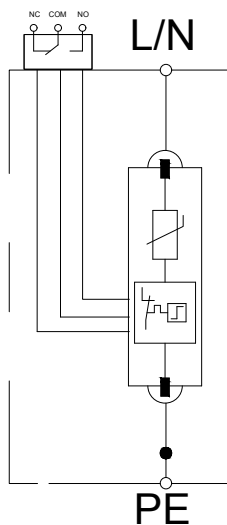

Dimensions & Packaging

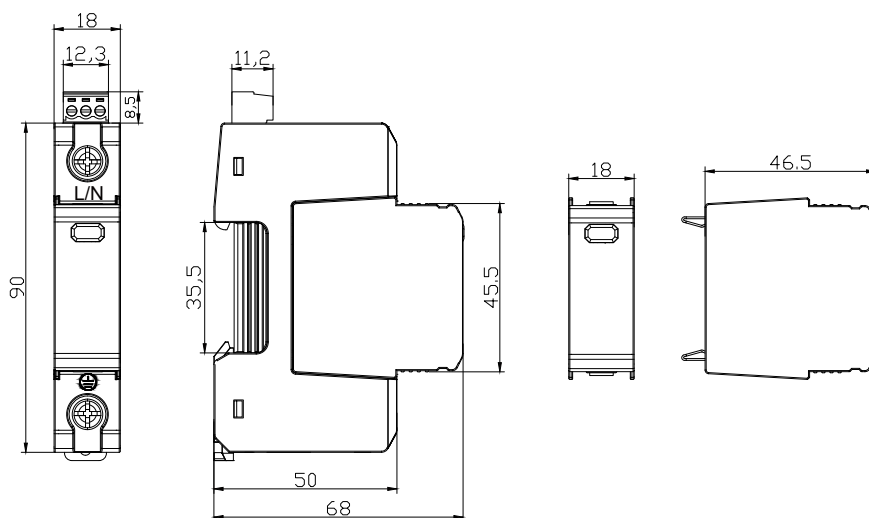

Connection Diagram

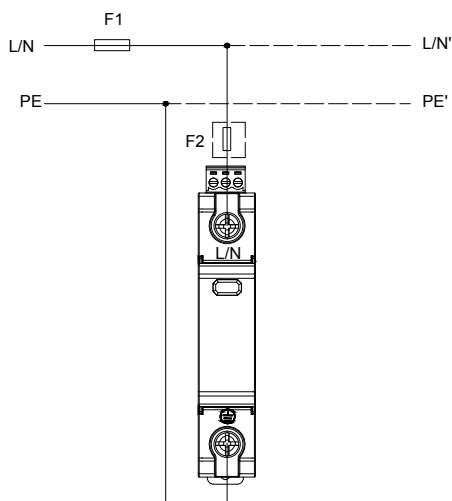

LY1-C40/2(S) Pluggable Single-Pole SPD



Class II • Type 2 • Type 1CA

Location of Use: Sub-Distribution Boards

Mode of Protection: L-PE, N-PE

Surge Ratings: $I_n = 20 \text{ kA}$ (8/20 μs)

IEC/EN/UL Category: Class II / Type 2 / Type 1CA

Protective Elements: High Energy MOV

Housing: Pluggable Design

Compliance: IEC 61643-11:2011

EN 61643-11:2012

■ Technical Data

IEC Electrical		75	150	275	320	385	440
Nominal AC Voltage (50/60Hz)	U_o / U_n	60 V	120 V	230 V	230 V	230 V	400 V
Maximum Continuous Operating Voltage (AC)	U_c	75 V	150 V	275V	320 V	385 V	440 V
Nominal Discharge Current (8/20 μs)	I_n	20 kA	20 kA	20 kA	20 kA	20 kA	20 kA
Maximum Discharge Current (8/20 μs)	I_{max}	40 kA	40 kA	40 kA	40 kA	40 kA	40 kA
Voltage Protection Level	U_p	0.4 kV	1 kV	1.5 kV	1.6 kV	1.8 kV	2 kV
Impulse Current (10/350 μs) I_{imp} (L-N)		7kA					
Response Time	t_A	< 25 ns					
Back-Up Fuse (max)		125 A gL / gG					
Short-Circuit Current Rating (AC)	I_{SCCR}	25 kA / 50 kA					
TOV Withstand 5s	U_T	90V	180V	335V	335V	335V	580V
TOV 120min	U_T	115V	230V	440V	440V	440V	765V
	mode	Withstand	Withstand	Safe Fail	Safe Fail	Safe Fail	Safe Fail
Mechanical & Environmental							
Operating Temperature Range	T_a	-40°F to +158°F [-40°C to +70°C]					
Permissible Operating Humidity	RH	5%...95%					
Atmospheric pressure and altitude		80k Pa ... 106k Pa / -500 m.....2000 m					
Terminal Screw Torque	M_{max}	39.9 lbf-in [4.5 Nm]					
Conductor Cross Section (max)		2 AWG (Solid, Stranded) / 4 AWG (Flexible) 35 mm ² (Solid, Stranded) / 25 mm ² (Flexible)					
Mounting		35 mm DIN Rail, EN 60715					
Degree of Protection		IP 20 (built-in)					
Housing Material		Thermoplastic: Extinguishing Degree UL 94 V-0					
Thermal Protection		Yes					
Operating State / Fault Indication		Green ok / Red defect					
Remote Contacts (RC)		Optional					
RC Switching Capacity		AC: 250V / 0.5 A; DC: 250V / 0.1 A; 125V / 0.2 A; 75V / 0.5 A					
RC Conductor Cross Section (max)		16 AWG (Solid) / 1.5 mm ² (Solid)					

LY1-C40/2(S)

Pluggable Single-Pole SPD



Internal Configuration

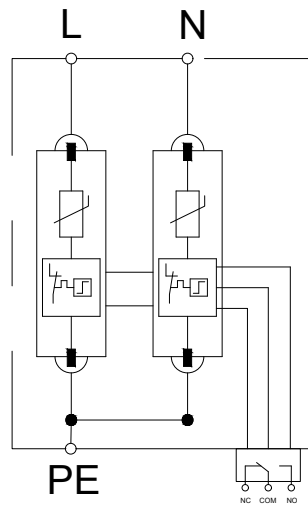

Dimensions & Packaging

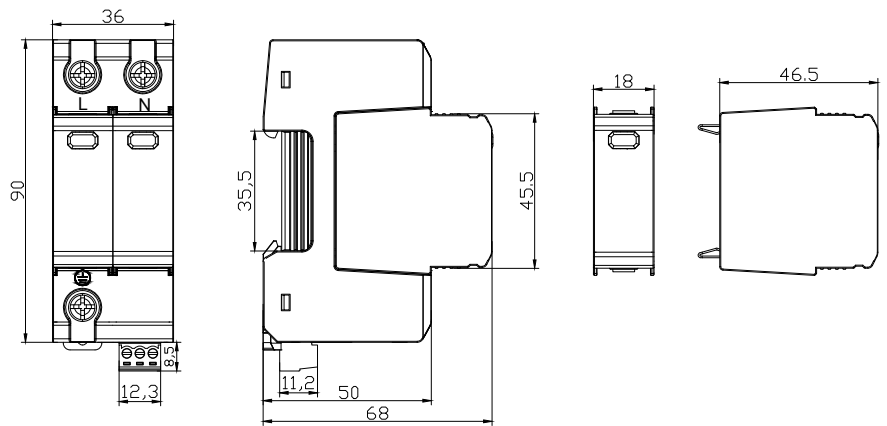

Connection Diagram

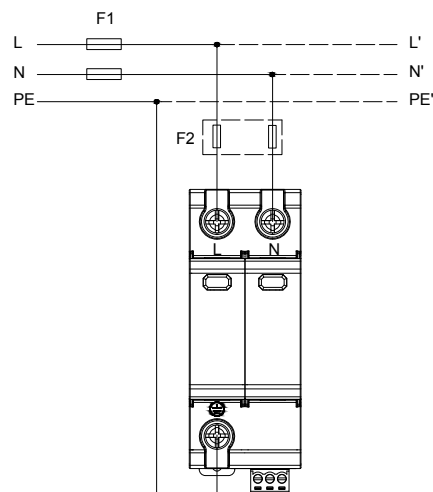



Class II • Type 2 • Type 1CA

Location of Use: Sub-Distribution Boards
 Mode of Protection: L-PE, N-PE
 Surge Ratings: $I_n = 20 \text{ kA}$ (8/20 μs)
 IEC/EN/UL Category: Class II / Type 2 / Type 1CA
 Protective Elements: High Energy MOV
 Housing: Pluggable Design
 Compliance: IEC 61643-11:2011
 EN 61643-11:2012

■ Technical Data

IEC Electrical		150	275	320	385	440
Nominal AC Voltage (50/60Hz)	U_o / U_n	120 V	230 V	230 V	230 V	400 V
Maximum Continuous Operating Voltage (AC)	U_c	150 V	275V	320 V	385 V	440 V
Nominal Discharge Current (8/20 μs)	I_n	20 kA	20 kA	20 kA	20 kA	20 kA
Maximum Discharge Current (8/20 μs)	I_{max}	40 kA	40 kA	40 kA	40 kA	40 kA
Voltage Protection Level	U_p	1 kV	1.5 kV	1.6 kV	1.8 kV	2 kV
Impulse Current (10/350 μs) I_{imp} (L-N)				7kA		
Response Time	t_A			< 25 ns		
Back-Up Fuse (max)				125 A gL / gG		
Short-Circuit Current Rating (AC)	I_{SCCR}			25 kA / 50 kA		
TOV Withstand 5s	U_T	180V	335V	335V	335V	580V
TOV 120min	U_T	230V	440V	440V	440V	765V
	mode	Withstand	Safe Fail	Safe Fail	Safe Fail	Safe Fail
Mechanical & Environmental						
Operating Temperature Range	T_a	-40°F to +158°F [-40°C to +70°C]				
Permissible Operating Humidity	RH	5%...95%				
Atmospheric pressure and altitude		80k Pa ... 106k Pa / -500 m.....2000 m				
Terminal Screw Torque	M_{max}	39.9 lbf-in [4.5 Nm]				
Conductor Cross Section (max)		2 AWG (Solid, Stranded) / 4 AWG (Flexible) 35 mm ² (Solid, Stranded) / 25 mm ² (Flexible)				
Mounting		35 mm DIN Rail, EN 60715				
Degree of Protection		IP 20 (built-in)				
Housing Material		Thermoplastic: Extinguishing Degree UL 94 V-0				
Thermal Protection		Yes				
Operating State / Fault Indication		Green ok / Red defect				
Remote Contacts (RC)		Optional				
RC Switching Capacity		AC: 250V / 0.5 A; DC: 250V / 0.1 A; 125V / 0.2 A; 75V / 0.5 A				
RC Conductor Cross Section (max)		16 AWG (Solid) / 1.5 mm ² (Solid)				

LY1-C40/3(S)

Pluggable Multi-Pole SPD



Internal Configuration

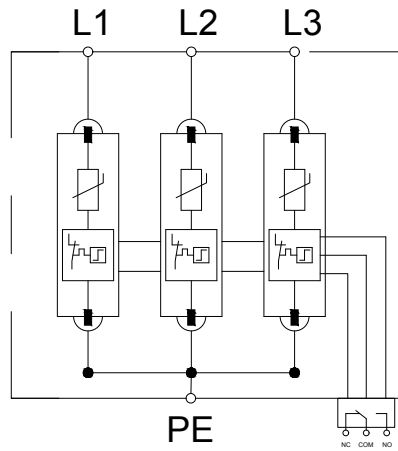

Dimensions & Packaging

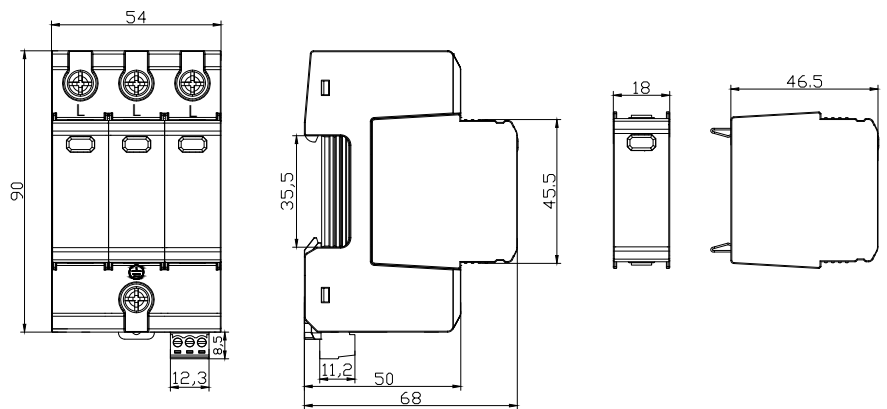

Connection Diagram

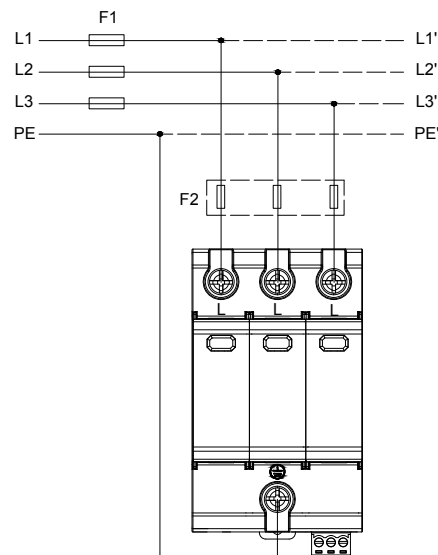

LY1-C40/4(S) Pluggable Multi-Pole SPD



Class II • Type 2 • Type 1CA

Location of Use: Sub-Distribution Boards
 Mode of Protection: L-PE, N-PE
 Surge Ratings: $I_n = 20 \text{ kA}$ (8/20 μs)
 IEC/EN/UL Category: Class II / Type 2 / Type 1CA
 Protective Elements: High Energy MOV
 Housing: Pluggable Design
 Compliance: IEC 61643-11:2011
 EN 61643-11:2012

■ Technical Data

IEC Electrical		150	275	320	385	440
Nominal AC Voltage (50/60Hz)	U_o / U_n	120 V	230 V	230 V	230 V	400 V
Maximum Continuous Operating Voltage (AC)	U_c	150 V	275V	320 V	385 V	440 V
Nominal Discharge Current (8/20 μs)	I_n	20 kA	20 kA	20 kA	20 kA	20 kA
Maximum Discharge Current (8/20 μs)	I_{max}	40 kA	40 kA	40 kA	40 kA	40 kA
Voltage Protection Level	U_p	1 kV	1.5 kV	1.6 kV	1.8 kV	2 kV
Impulse Current (10/350 μs) I_{imp} (L-N)				7kA		
Response Time	t_A			< 25 ns		
Back-Up Fuse (max)				125 A gL / gG		
Short-Circuit Current Rating (AC)	I_{SCCR}			25 kA / 50 kA		
TOV Withstand 5s	U_T	180V	335V	335V	335V	580V
TOV 120min	U_T	230V	440V	440V	440V	765V
	mode	Withstand	Safe Fail	Safe Fail	Safe Fail	Safe Fail
Mechanical & Environmental						
Operating Temperature Range	T_a	-40°F to +158°F [-40°C to +70°C]				
Permissible Operating Humidity	RH	5%...95%				
Atmospheric pressure and altitude		80k Pa ... 106k Pa / -500 m.....2000 m				
Terminal Screw Torque	M_{max}	39.9 lbf-in [4.5 Nm]				
Conductor Cross Section (max)		2 AWG (Solid, Stranded) / 4 AWG (Flexible) 35 mm ² (Solid, Stranded) / 25 mm ² (Flexible)				
Mounting		35 mm DIN Rail, EN 60715				
Degree of Protection		IP 20 (built-in)				
Housing Material		Thermoplastic: Extinguishing Degree UL 94 V-0				
Thermal Protection		Yes				
Operating State / Fault Indication		Green ok / Red defect				
Remote Contacts (RC)		Optional				
RC Switching Capacity		AC: 250V / 0.5 A; DC: 250V / 0.1 A; 125V / 0.2 A; 75V / 0.5 A				
RC Conductor Cross Section (max)		16 AWG (Solid) / 1.5 mm ² (Solid)				

LY1-C40/4(S)

Pluggable Multi-Pole SPD



Internal Configuration

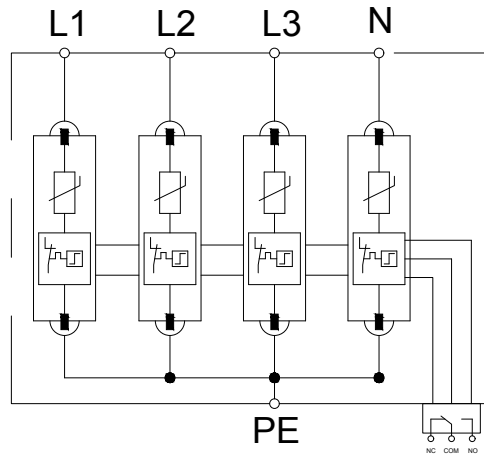

Dimensions & Packaging

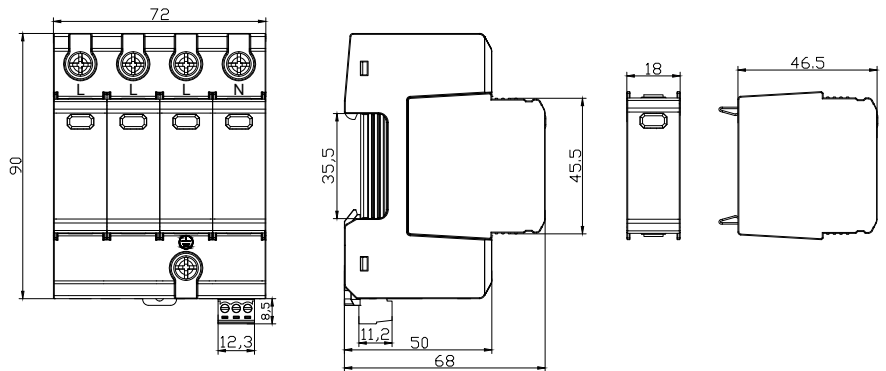

Connection Diagram

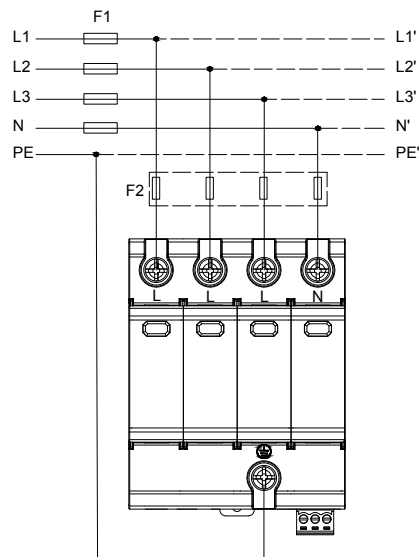

LY1-C40/1(S)+1 Pluggable Single-Pole SPD



Class II • Type 2 • Type 1CA

Location of Use: Sub-Distribution Boards
 Mode of Protection: L-N, N-PE
 Surge Ratings: $I_n = 20 \text{ kA}$ (8/20 μs)
 IEC/EN/UL Category: Class II / Type 2 / Type 1CA
 Protective Elements: High Energy MOV
 Housing: Pluggable Design
 Compliance: IEC 61643-11:2011
 EN 61643-11:2012

■ Technical Data

IEC Electrical		75	150	275	320	385	440
Nominal AC Voltage (50/60Hz)		60 V	120 V	230 V	230 V	230 V	400 V
Maximum Continuous Operating Voltage (AC)	(L-N) U_c	75 V	150 V	275 V	320 V	385 V	440 V
	(N-PE) U_c	255V					
Nominal Discharge Current (8/20 μs)	(L-N) / (N-PE) I_n	20kV / 20kA					
Maximum Discharge Current (8/20 μs)	(L-N) / (N-PE) I_{max}	40 kA / 40 kA					
Voltage Protection Level	(L-N) / (N-PE) U_p	0.4kV/1.5kV	1.0kV/1.5kV	1.5kV/1.5kV	1.6kV/1.5kV	1.8kV/1.5kV	2.0kV/1.5kV
Follow Current Interrupt Rating	(N-PE) I_{fi}	100A _{RMS}					
Response Time	(L-N) / (N-PE) t_A	< 25 ns / < 100 ns					
Back-Up Fuse (max)		125 A gL / gG					
Short-Circuit Current Rating (AC)	(L-N) I_{SCCR}	25 kA / 50 kA					
TOV Withstand 5s	(L-N) U_T	90V	180V	335V	335V	335V	580V
TOV 120min	(L-N) U_T	115V	230V	440V	440V	440V	765V
		mode	Withstand	Withstand	Safe Fail	Safe Fail	Safe Fail
TOV Withstand 200ms	(N-PE) U_T	1200V					
Mechanical & Environmental							
Operating Temperature Range	T_a	-40°F to +158°F [-40°C to +70°C]					
Permissible Operating Humidity	RH	5%...95%					
Atmospheric pressure and altitude		80k Pa ... 106k Pa / -500 m.....2000 m					
Terminal Screw Torque	M_{max}	39.9 lbf-in [4.5 Nm]					
Conductor Cross Section (max)		2 AWG (Solid, Stranded) / 4 AWG (Flexible)					
		35 mm ² (Solid, Stranded) / 25 mm ² (Flexible)					
Mounting		35 mm DIN Rail, EN 60715					
Degree of Protection		IP 20 (built-in)					
Housing Material		Thermoplastic: Extinguishing Degree UL 94 V-0					
Thermal Protection		Yes					
Operating State / Fault Indication		Green ok / Red defect					
Remote Contacts (RC)		Optional					
RC Switching Capacity		AC: 250V / 0.5 A; DC: 250V / 0.1 A; 125 V / 0.2 A; 75 V / 0.5 A					
RC Conductor Cross Section (max)		16 AWG (Solid) / 1.5 mm ² (Solid)					

LY1-C40/1(S)+1

Pluggable Single-Pole SPD



Internal Configuration

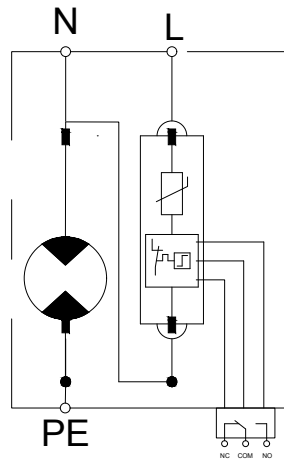

Dimensions & Packaging

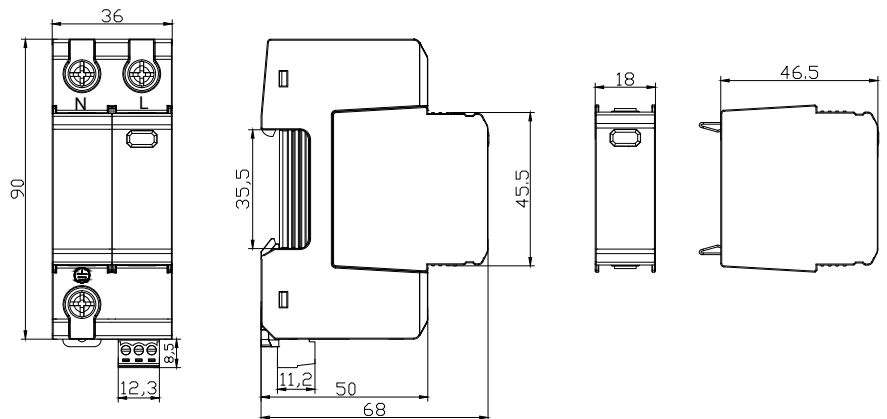

Connection Diagram

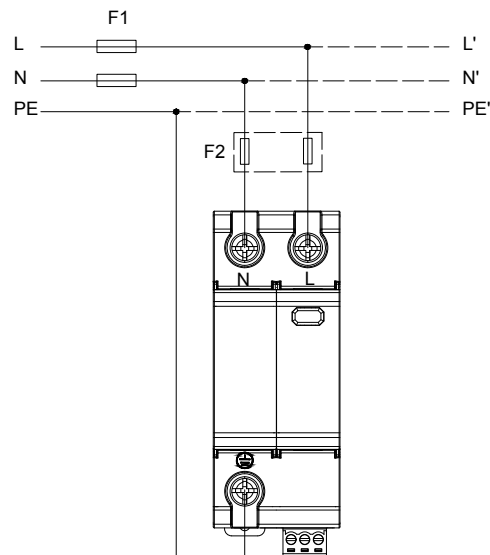

LY1-C40/3(S)+1 Pluggable Multi-Pole SPD



Class II • Type 2 • Type 1CA

Location of Use: Sub-Distribution Boards

Mode of Protection: L-N, N-PE

Surge Ratings: $I_n = 20 \text{ kA}$ (8/20 μs)

IEC/EN/UL Category: Class II / Type 2 / Type 1CA

Protective Elements: High Energy MOV

Housing: Pluggable Design

Compliance: IEC 61643-11:2011

EN 61643-11:2012

■ Technical Data

IEC Electrical		150	275	320	385	440
Nominal AC Voltage (50/60Hz)		120 V	230 V	230 V	230 V	400 V
Maximum Continuous Operating Voltage (AC)	(L-N) U_c	150 V	275 V	320 V	385 V	440 V
	(N-PE) U_c			255V		
Nominal Discharge Current (8/20 μs)	(L-N) / (N-PE) I_n			20kV / 20kA		
Maximum Discharge Current (8/20 μs)	(L-N) / (N-PE) I_{max}			40 kA / 40 kA		
Voltage Protection Level	(L-N) / (N-PE) U_p	1.0kV/1.5kV	1.5kV/1.5kV	1.6kV/1.5kV	1.8kV/1.5kV	2.0kV/1.5kV
Follow Current Interrupt Rating	(N-PE) I_{fi}			100A _{RMS}		
Response Time	(L-N) / (N-PE) t_A			< 25 ns / < 100 ns		
Back-Up Fuse (max)				125 A gL / gG		
Short-Circuit Current Rating (AC)	(L-N) I_{SCCR}			25 kA / 50 kA		
TOV Withstand 5s	(L-N) U_T	180V	335V	335V	335V	580V
TOV 120min	(L-N) U_T	230V	440V	440V	440V	765V
	mode	Withstand	Safe Fail	Safe Fail	Safe Fail	Safe Fail
TOV Withstand 200ms	(N-PE) U_T			1.2 kV		
Mechanical & Environmental						
Operating Temperature Range	T_a	-40°F to +158°F [-40°C to +70°C]				
Permissible Operating Humidity	RH	5%...95%				
Atmospheric pressure and altitude		80k Pa ... 106k Pa / -500 m.....2000 m				
Terminal Screw Torque	M_{max}	39.9 lbf-in [4.5 Nm]				
Conductor Cross Section (max)		2 AWG (Solid, Stranded) / 4 AWG (Flexible)				
		35 mm ² (Solid, Stranded) / 25 mm ² (Flexible)				
Mounting		35 mm DIN Rail, EN 60715				
Degree of Protection		IP 20 (built-in)				
Housing Material		Thermoplastic: Extinguishing Degree UL 94 V-0				
Thermal Protection		Yes				
Operating State / Fault Indication		Green ok / Red defect				
Remote Contacts (RC)		Optional				
RC Switching Capacity		AC: 250V / 0.5 A; DC: 250V / 0.1 A; 125 V / 0.2 A; 75 V / 0.5 A				
RC Conductor Cross Section (max)		16 AWG (Solid) / 1.5 mm ² (Solid)				

LY1-C40/3(S)+1

Pluggable Multi-Pole SPD



Internal Configuration

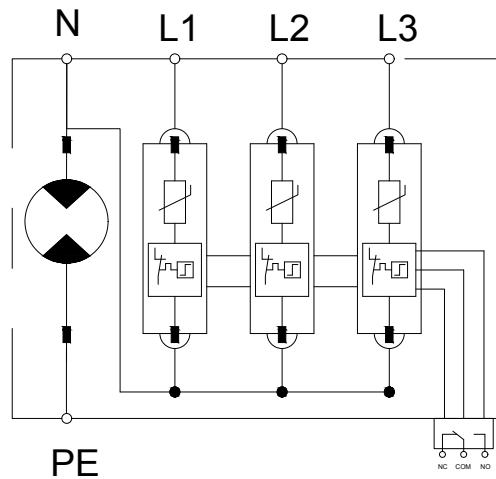

Dimensions & Packaging

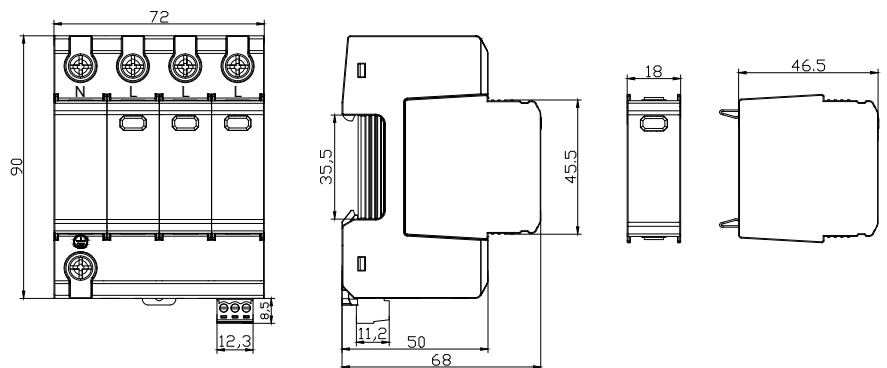

Connection Diagram

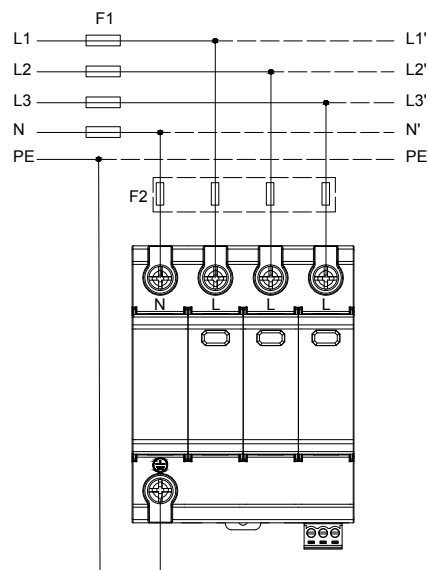



Class II • Type 2 • Type 1CA

Location of Use: Sub-Distribution Boards

Mode of Protection: L-PE, N-PE

Surge Ratings: $I_n = 20 \text{ kA}$ (8/20 μs)

IEC/EN/UL Category: Class II / Type 2 / Type 1CA

Protective Elements: High Energy MOV

Housing: Pluggable Design

Compliance: IEC 61643-11:2011

EN 61643-11:2012

■ Technical Data

IEC Electrical		600			
Nominal AC Voltage	U_o / U_n	600V			
Maximum Continuous Operating Voltage (DC)	U_c	600V			
Nominal Discharge Current (8/20 μs)	I_n	20 kA			
Maximum Discharge Current (8/20 μs)	I_{max}	40 kA			
Impulse Discharge Current (10/350 μs)	I_{imp}	6.25kA			
Voltage Protection Level	U_p	2.2kV			
Impulse Current (10/350 μs) I_{imp} (L-N)		7kA			
Response Time	t_A	< 25 ns			
Back-Up Fuse (max)		125 A gL / gG			
Short-Circuit Current Rating (AC)	I_{SCCR}	25 kA / 50 kA			
TOV Withstand 5s	U_T	?			
TOV 120min	U_T	?			
	mode	Withstand	Safe Fail	Safe Fail	Safe Fail
Mechanical & Environmental					
Operating Temperature Range	T_a	-40°F to +158°F [-40°C to +70°C]			
Permissible Operating Humidity	RH	5%...95%			
Atmospheric pressure and altitude		80k Pa ... 106k Pa / -500 m.....2000 m			
Terminal Screw Torque	M_{max}	39.9 lbf·in [4.5 Nm]			
Conductor Cross Section (max)		2 AWG (Solid, Stranded) / 4 AWG (Flexible)			
		35 mm ² (Solid, Stranded) / 25 mm ² (Flexible)			
Mounting		35 mm DIN Rail, EN 60715			
Degree of Protection		IP 20 (built-in)			
Housing Material		Thermoplastic: Extinguishing Degree UL 94 V-0			
Thermal Protection		Yes			
Operating State / Fault Indication		Green ok / Red defect			
Remote Contacts (RC)		Optional			
RC Switching Capacity		AC: 250V / 0.5 A; DC: 250V / 0.1 A;125V / 0.2 A;75V / 0.5 A			
RC Conductor Cross Section (max)		16 AWG (Solid) / 1.5 mm ² (Solid)			

LY1-C40PV/2(S) 600V

Pluggable Single-Pole SPD



Internal Configuration

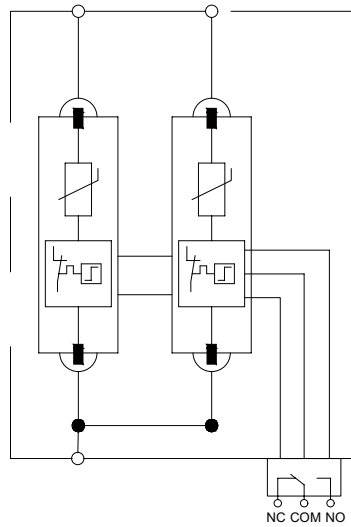

Dimensions & Packaging

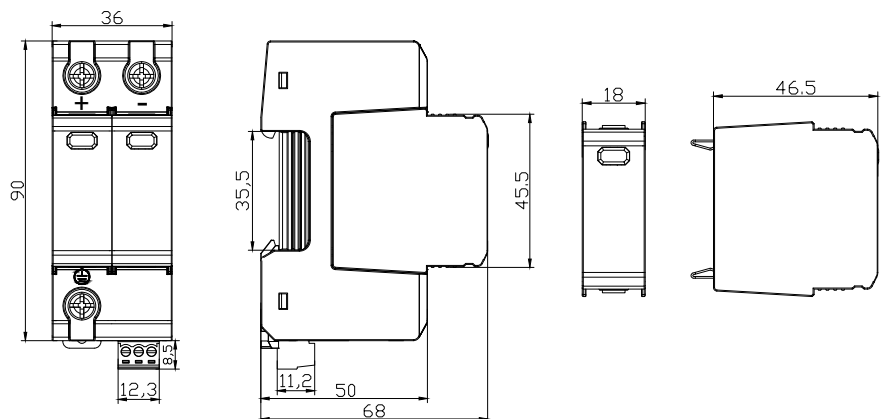

Connection Diagram

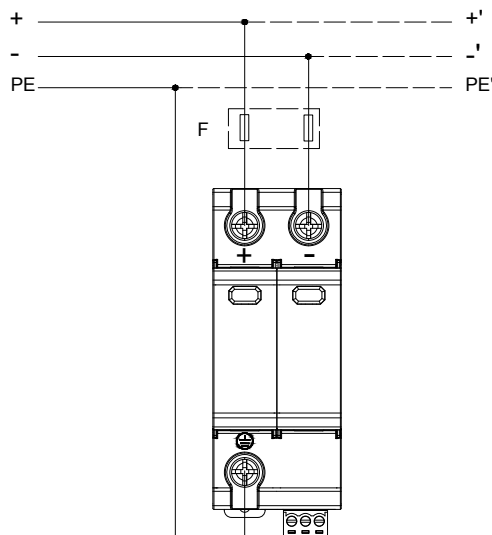



Class II • Type 2

Location of Use: Sub-Distribution Boards

Mode of Protection: (DC+) - PE, (DC-) - PE

Surge Ratings: $I_n = 20 \text{ kA}$ (8/20 μs)

IEC/EN/UL Category: Class II / Type 2

Protective Elements: High Energy MOV

Housing: Pluggable Design

Compliance: IEC 61643-31:2018

EN 50539-11:2013+A1:2014

■ Technical Data

IEC Electrical		600
Nominal DC Voltage	U_o / U_n	600V
Maximum Continuous Operating Voltage (DC)	U_c	600V
Nominal Discharge Current (8/20 μs)	I_n	20 kA
Maximum Discharge Current (8/20 μs)	I_{max}	40 kA
Impulse Discharge Current (10/350 μs)	I_{imp}	6.25kA
Voltage Protection Level	U_p	2.2kV
Response Time	t_A	< 25 ns
Back-Up Fuse (max)		125 A gL / gG
Short-Circuit Current Rating (AC)	I_{SCCR}	25 kA / 50 kA
Mechanical & Environmental		
Operating Temperature Range	T_a	-40°F to +158°F [-40°C to +70°C]
Permissible Operating Humidity	RH	5%...95%
Atmospheric pressure and altitude		80k Pa ... 106k Pa / -500 m.....2000 m
Terminal Screw Torque	M_{max}	39.9 lbf-in [4.5 Nm]
Conductor Cross Section (max)		2 AWG (Solid, Stranded) / 4 AWG (Flexible)
		35 mm ² (Solid, Stranded) / 25 mm ² (Flexible)
Mounting		35 mm DIN Rail, EN 60715
Degree of Protection		IP 20 (built-in)
Housing Material		Thermoplastic: Extinguishing Degree UL 94 V-0
Thermal Protection		Yes
Operating State / Fault Indication		Green ok / Red defect
Remote Contacts (RC)		Optional
RC Switching Capacity		AC: 250V / 0.5 A; DC: 250V / 0.1 A; 125V / 0.2 A; 75V / 0.5 A
RC Conductor Cross Section (max)		16 AWG (Solid) / 1.5 mm ² (Solid)

LY1-C40PV/3(S) 600V

Pluggable Multi-Pole SPD



Internal Configuration

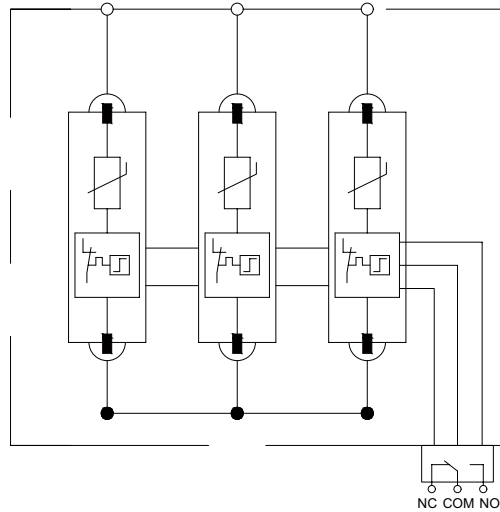

Dimensions & Packaging

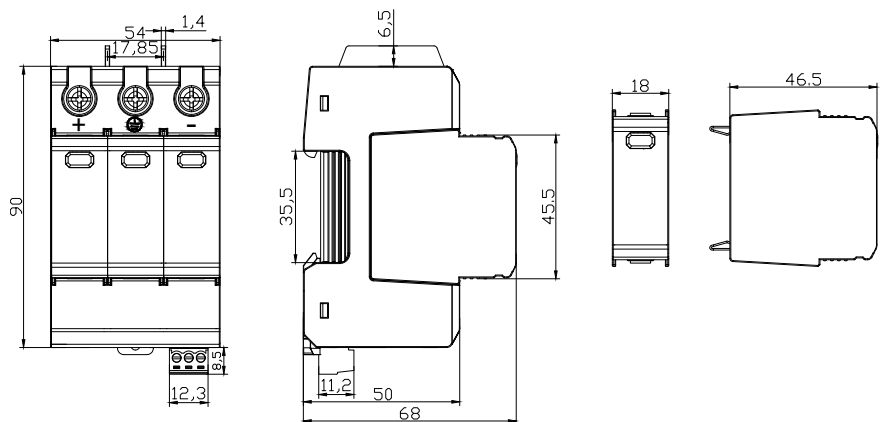

Connection Diagram

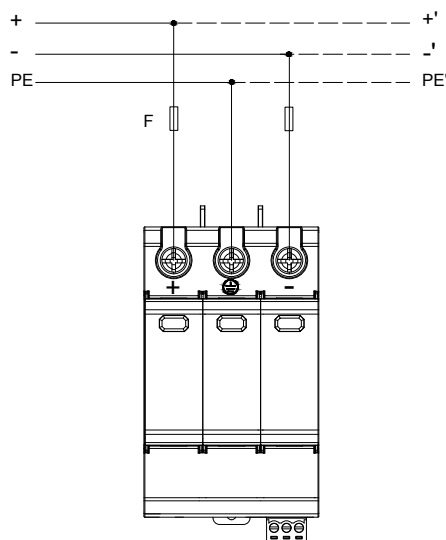

LY1-C40PV/2(S) 1000V

Pluggable Single-Pole SPD



Class I • Class II • Type 1 • Type 2

Location of Use: Sub-Distribution Boards
 Mode of Protection: (DC+) - PE, (DC-) - PE
 Surge Ratings: $I_n = 20 \text{ kA}$ (8/20 μs)
 IEC/EN/UL Category: Class I+II / Type 1+2
 Protective Elements: High Energy MOV
 Housing: Pluggable Design
 Compliance: IEC 61643-31:2018
 EN 50539-11:2013+A1:2014

■ Technical Data

IEC Electrical		1000
Nominal AC Voltage	U_o / U_n	1000 V
Maximum Continuous Operating Voltage (DC)	U_c	1000 V
Nominal Discharge Current (8/20 μs)	I_n	20 kA
Maximum Discharge Current (8/20 μs)	I_{max}	40 kA
Impulse Discharge Current (10/350 μs)	I_{imp}	6.25 kA
Voltage Protection Level	U_p	3.6 kV
Response Time	t_A	< 25 ns
Back-Up Fuse (max)		125 A gL / gG
Short-Circuit Current Rating (AC)	I_{SCCR}	25 kA / 50 kA
Mechanical & Environmental		
Operating Temperature Range	T_a	-40°F to +158°F [-40°C to +70°C]
Permissible Operating Humidity	RH	5%...95%
Atmospheric pressure and altitude		80k Pa ... 106k Pa / -500 m.....2000 m
Terminal Screw Torque	M_{max}	39.9 lbf-in [4.5 Nm]
Conductor Cross Section (max)		2 AWG (Solid, Stranded) / 4 AWG (Flexible) 35 mm ² (Solid, Stranded) / 25 mm ² (Flexible)
Mounting		35 mm DIN Rail, EN 60715
Degree of Protection		IP 20 (built-in)
Housing Material		Thermoplastic: Extinguishing Degree UL 94 V-0
Thermal Protection		Yes
Operating State / Fault Indication		Green ok / Red defect
Remote Contacts (RC)		Optional
RC Switching Capacity		AC: 250V / 0.5 A; DC: 250V / 0.1 A; 125V / 0.2 A; 75V / 0.5 A
RC Conductor Cross Section (max)		16 AWG (Solid) / 1.5 mm ² (Solid)

LY1-C40PV/2(S) 1000V

Pluggable Single-Pole SPD



Internal Configuration

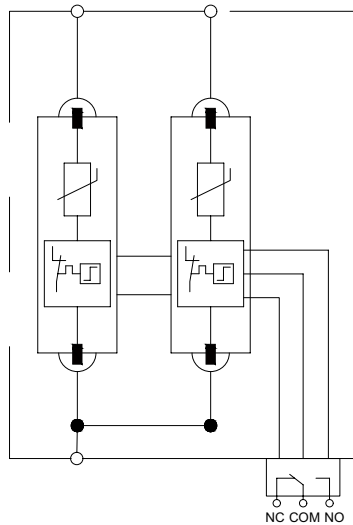

Dimensions & Packaging

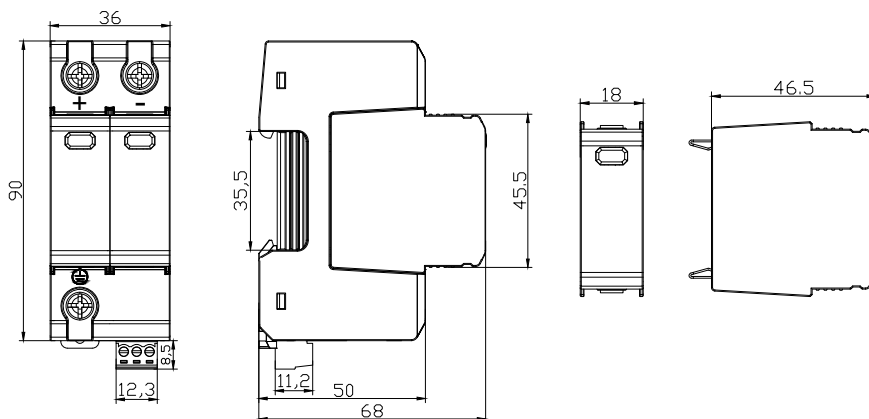

Connection Diagram

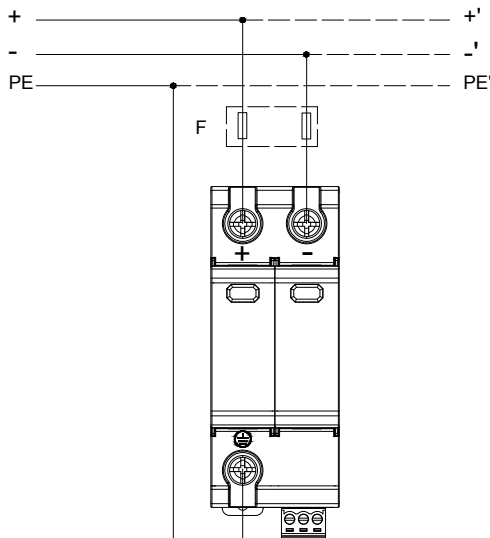



Class I • Class II • Type 1 • Type 2

Location of Use: Sub-Distribution Boards

Mode of Protection: (DC+) - PE, (DC-) - PE

Surge Ratings: $I_n = 20 \text{ kA}$ (8/20 μs)

IEC/EN/UL Category: Class I+II / Type 1+2

Protective Elements: High Energy MOV

Housing: Pluggable Design

Compliance: IEC 61643-31:2018

EN 50539-11:2013+A1:2014

■ Technical Data

IEC Electrical		1000
Nominal AC Voltage	U_o / U_n	1000 V
Maximum Continuous Operating Voltage (DC)	U_c	1000 V
Nominal Discharge Current (8/20 μs)	I_n	20 kA
Maximum Discharge Current (8/20 μs)	I_{max}	40 kA
Impulse Discharge Current (10/350 μs)	I_{imp}	6.25 kA
Voltage Protection Level	U_p	3.6 kV
Response Time	t_A	< 25 ns
Back-Up Fuse (max)		125 A gL / gG
Short-Circuit Current Rating (AC)	I_{SCCR}	25 kA / 50 kA
Mechanical & Environmental		
Operating Temperature Range	T_a	-40°F to +158°F [-40°C to +70°C]
Permissible Operating Humidity	RH	5%...95%
Atmospheric pressure and altitude		80k Pa ... 106k Pa / -500 m.....2000 m
Terminal Screw Torque	M_{max}	39.9 lbf-in [4.5 Nm]
Conductor Cross Section (max)		2 AWG (Solid, Stranded) / 4 AWG (Flexible)
		35 mm ² (Solid, Stranded) / 25 mm ² (Flexible)
Mounting		35 mm DIN Rail, EN 60715
Degree of Protection		IP 20 (built-in)
Housing Material		Thermoplastic: Extinguishing Degree UL 94 V-0
Thermal Protection		Yes
Operating State / Fault Indication		Green ok / Red defect
Remote Contacts (RC)		Optional
RC Switching Capacity		AC: 250V / 0.5 A; DC: 250V / 0.1 A; 125V / 0.2 A; 75V / 0.5 A
RC Conductor Cross Section (max)		16 AWG (Solid) / 1.5 mm ² (Solid)

LY1-C40PV/3(S) 1000V

Pluggable Multi-Pole SPD



Internal Configuration

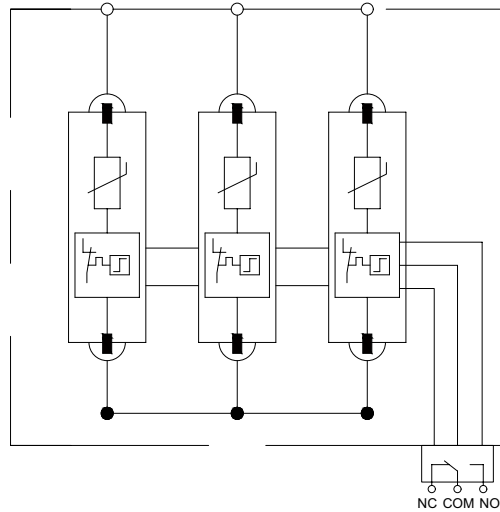

Dimensions & Packaging

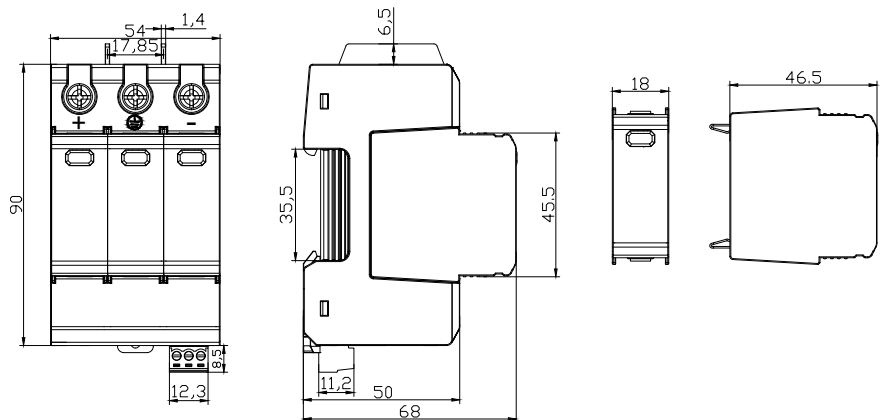

Connection Diagram

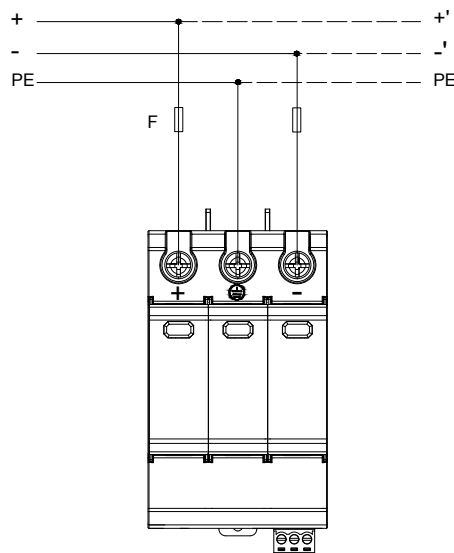



Class I • Class II • Type 1 • Type 2

Location of Use: Sub-Distribution Boards
 Mode of Protection: (DC+) - PE, (DC-) - PE
 Surge Ratings: $I_n = 20 \text{ kA}$ (8/20 μs)
 IEC/EN/UL Category: Class I+II / Type 1+2
 Protective Elements: High Energy MOV
 Housing: Pluggable Design
 Compliance: IEC 61643-31:2018
 EN 50539-11:2013+A1:2014

■ Technical Data

IEC Electrical		1000
Nominal AC Voltage	U_o / U_n	1000 V
Maximum Continuous Operating Voltage (DC)	U_c	1000 V
Nominal Discharge Current (8/20 μs)	I_n	20 kA
Maximum Discharge Current (8/20 μs)	I_{max}	40 kA
Impulse Discharge Current (10/350 μs)	I_{imp}	6.25 kA
Voltage Protection Level	U_p	3.6 kV
Response Time	t_A	< 25 ns
Back-Up Fuse (max)		125 A gL / gG
Short-Circuit Current Rating (AC)	I_{SCCR}	25 kA / 50 kA
Mechanical & Environmental		
Operating Temperature Range	T_a	-40°F to +158°F [-40°C to +70°C]
Permissible Operating Humidity	RH	5%...95%
Atmospheric pressure and altitude		80k Pa ... 106k Pa / -500 m.....2000 m
Terminal Screw Torque	M_{max}	39.9 lbf-in [4.5 Nm]
Conductor Cross Section (max)		2 AWG (Solid, Stranded) / 4 AWG (Flexible) 35 mm ² (Solid, Stranded) / 25 mm ² (Flexible)
Mounting		35 mm DIN Rail, EN 60715
Degree of Protection		IP 20 (built-in)
Housing Material		Thermoplastic: Extinguishing Degree UL 94 V-0
Thermal Protection		Yes
Operating State / Fault Indication		Green ok / Red defect
Remote Contacts (RC)		Optional
RC Switching Capacity		AC: 250V / 0.5 A; DC: 250V / 0.1 A; 125V / 0.2 A; 75V / 0.5 A
RC Conductor Cross Section (max)		16 AWG (Solid) / 1.5 mm ² (Solid)

LY1-C40PV/3(S) 1000V(D4)

Pluggable Multi-Pole SPD



Internal Configuration

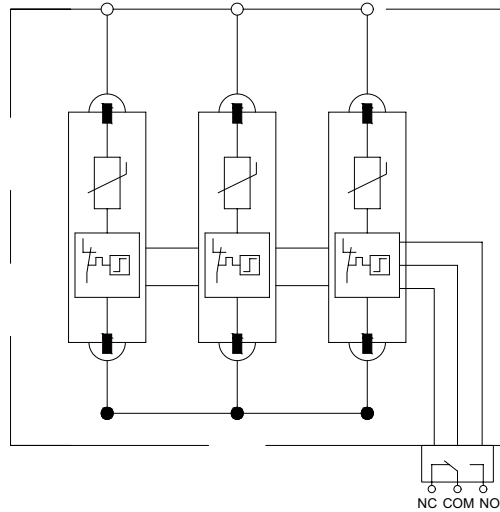

Dimensions & Packaging

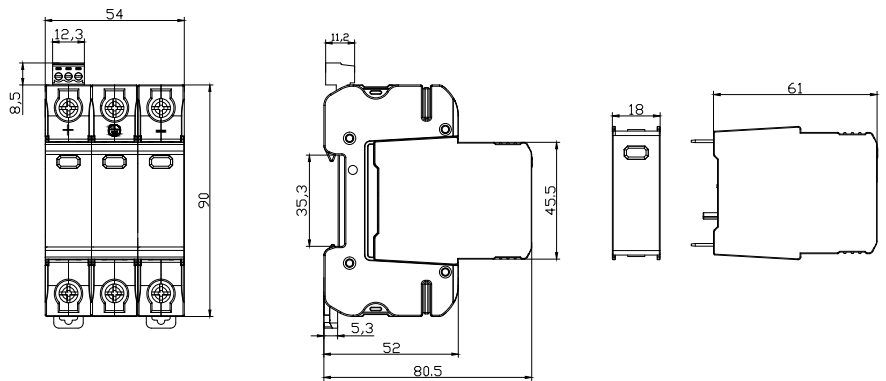

Connection Diagram

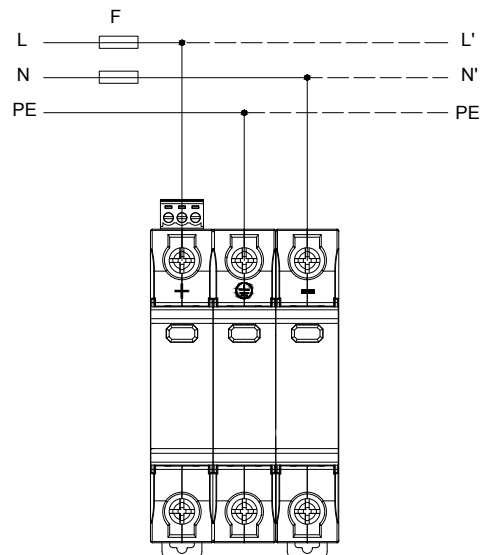



Class I • Class II • Type 1 • Type 2

Location of Use: Sub-Distribution Boards
 Mode of Protection: (DC+) - PE, (DC-) - PE
 Surge Ratings: $I_n = 20 \text{ kA}$ (8/20 μs)
 IEC/EN/UL Category: Class I+II / Type 1+2
 Protective Elements: High Energy MOV
 Housing: Pluggable Design
 Compliance: IEC 61643-31:2018
 EN 50539-11:2013+A1:2014

■ Technical Data

IEC Electrical		1500
Nominal AC Voltage	U_o / U_n	1500 V
Maximum Continuous Operating Voltage (DC)	U_c	1500 V
Nominal Discharge Current (8/20 μs)	I_n	20 kA
Maximum Discharge Current (8/20 μs)	I_{max}	40 kA
Impulse Discharge Current (10/350 μs)	I_{imp}	6.25 kA
Voltage Protection Level	U_p	5.6 kV
Response Time	t_A	< 25 ns
Back-Up Fuse (max)		125 A gL / gG
Short-Circuit Current Rating (AC)	I_{SCCR}	25 kA / 50 kA
Mechanical & Environmental		
Operating Temperature Range	T_a	-40°F to +158°F [-40°C to +70°C]
Permissible Operating Humidity	RH	5%...95%
Atmospheric pressure and altitude		80k Pa ... 106k Pa / -500 m.....2000 m
Terminal Screw Torque	M_{max}	39.9 lbf-in [4.5 Nm]
Conductor Cross Section (max)		2 AWG (Solid, Stranded) / 4 AWG (Flexible) 35 mm ² (Solid, Stranded) / 25 mm ² (Flexible)
Mounting		35 mm DIN Rail, EN 60715
Degree of Protection		IP 20 (built-in)
Housing Material		Thermoplastic: Extinguishing Degree UL 94 V-0
Thermal Protection		Yes
Operating State / Fault Indication		Green ok / Red defect
Remote Contacts (RC)		Optional
RC Switching Capacity		AC: 250V / 0.5 A; DC: 250V / 0.1 A; 125V / 0.2 A; 75V / 0.5 A
RC Conductor Cross Section (max)		16 AWG (Solid) / 1.5 mm ² (Solid)

LY1-C40PV/3(S) 1500V(D4)

Pluggable Multi-Pole SPD



Internal Configuration

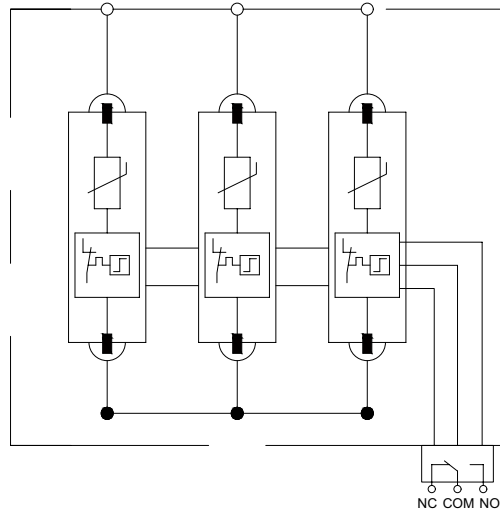

Dimensions & Packaging

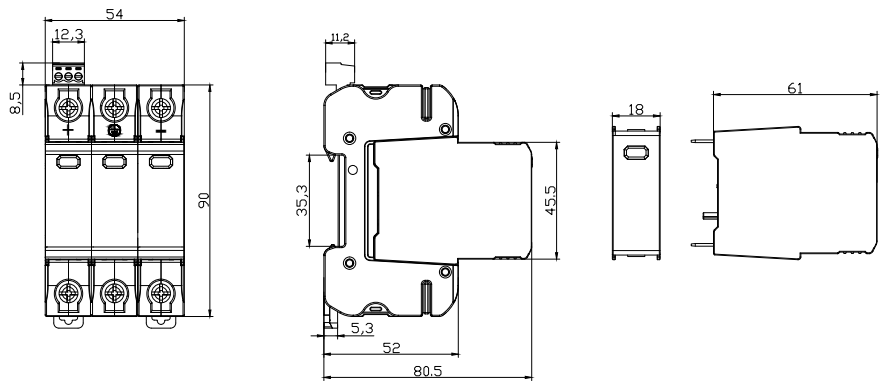

Connection Diagram

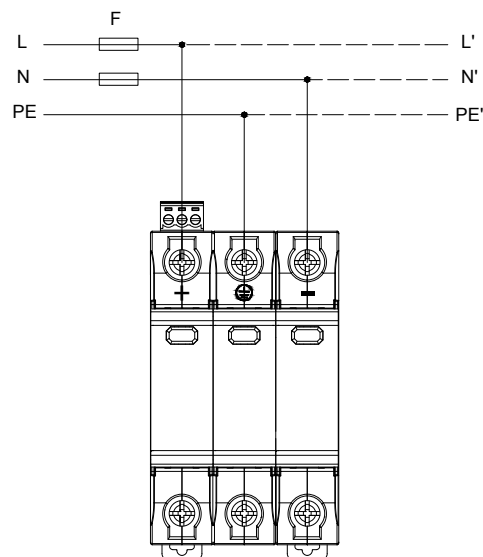

LY1-D20M/2(S) Pluggable Single-Pole SPD



Class II • Class III • Type 2 • Type 3

Location of Use: Sub-Distribution Boards
 Mode of Protection: L-PE, N-PE
 Surge Ratings: $I_n = 10 \text{ kA}$ (8/20 μs)
 IEC/EN/UL Category: Class II+III / Type 2+3
 Protective Elements: High Energy MOV
 Housing: Pluggable Design
 Compliance: IEC 61643-11:2011
 EN 61643-11:2012

■ Technical Data

IEC Electrical		75	150	275	320	385	440
Nominal AC Voltage (50/60Hz)	U_o / U_n	60 V	120 V	230 V	230 V	230 V	400 V
Maximum Continuous Operating Voltage (AC)	U_c	75 V	150 V	275V	320 V	385 V	440 V
Nominal Discharge Current (8/20 μs)	I_n	10 kA	10 kA	10 kA	10 kA	10 kA	10 kA
Maximum Discharge Current (8/20 μs)	I_{max}	20 kA	20 kA	20 kA	20 kA	20 kA	20 kA
Voltage Protection Level	U_p	0.2 kV	0.6 kV	1.3 kV	1.5 kV	1.5 kV	1.8 kV
Response Time	t_A	< 25 ns					
Back-Up Fuse (max)		125 A gL / gG					
Short-Circuit Current Rating (AC)	I_{SCCR}	10 kA					
TOV Withstand 5s	U_T	90V	180V	335V	335V	335V	580V
TOV 120min	U_T	115V	230V	440V	440V	440V	765V
	mode	Withstand	Withstand	Safe Fail	Safe Fail	Safe Fail	Safe Fail
Mechanical & Environmental							
Operating Temperature Range	T_a	-40°F to +158°F [-40°C to +70°C]					
Permissible Operating Humidity	RH	5%...95%					
Atmospheric pressure and altitude		80k Pa ... 106k Pa / -500 m.....2000 m					
Terminal Screw Torque	M_{max}	39.9 lbf-in [4.5 Nm]					
Conductor Cross Section (max)		2 AWG (Solid, Stranded) / 4 AWG (Flexible) 35 mm ² (Solid, Stranded) / 25 mm ² (Flexible)					
Mounting		35 mm DIN Rail, EN 60715					
Degree of Protection		IP 20 (built-in)					
Housing Material		Thermoplastic: Extinguishing Degree UL 94 V-0					
Thermal Protection		Yes					
Operating State / Fault Indication		Green ok / Red defect					
Remote Contacts (RC)		Optional					
RC Switching Capacity		AC: 250V / 0.5 A; DC: 250V / 0.1 A; 125V / 0.2 A; 75V / 0.5 A					
RC Conductor Cross Section (max)		16 AWG (Solid) / 1.5 mm ² (Solid)					

LY1-D20M/2(S)

Pluggable Single-Pole SPD



Internal Configuration

Legend

- L Line
- N Neutral
- PE Protective Earth
- S Signalling Contacts Optional

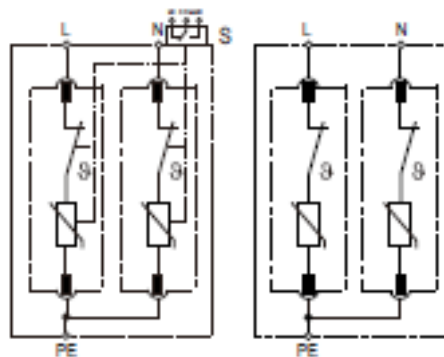

Dimensions & Packaging

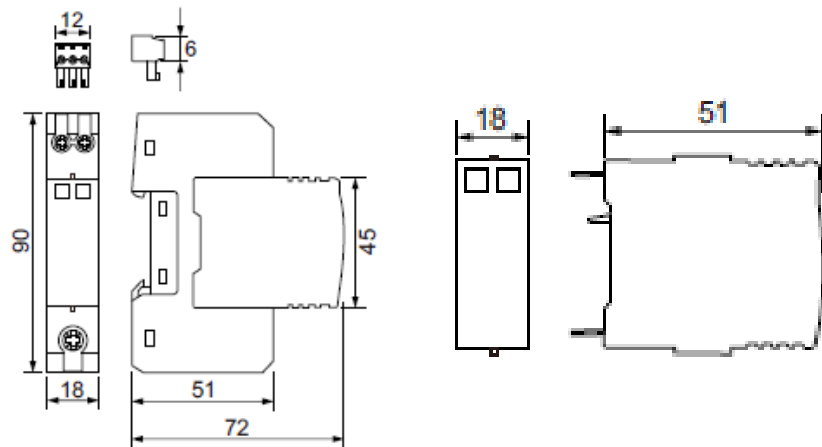

Connection Diagram

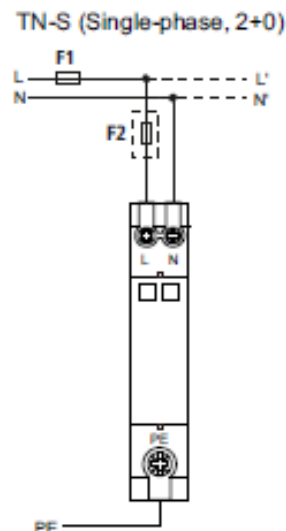

LY1-D20M/4(S) Pluggable Multi-Pole SPD



Class II • Class III • Type 2 • Type 3

Location of Use: Sub-Distribution Boards
 Mode of Protection: L-PE, N-PE
 Surge Ratings: $I_n = 10 \text{ kA}$ (8/20 μs)
 IEC/EN/UL Category: Class II+III / Type 2+3
 Protective Elements: High Energy MOV
 Housing: Pluggable Design
 Compliance: IEC 61643-11:2011
 EN 61643-11:2012

■ Technical Data

IEC Electrical		150	275	320	385	440
Nominal AC Voltage (50/60Hz)	U_o / U_n	120 V	230 V	230 V	230 V	400 V
Maximum Continuous Operating Voltage (AC)	U_c	150 V	275V	320 V	385 V	440 V
Nominal Discharge Current (8/20 μs)	I_n	10 kA	10 kA	10 kA	10 kA	10 kA
Maximum Discharge Current (8/20 μs)	I_{max}	20 kA	20 kA	20 kA	20 kA	20 kA
Voltage Protection Level	U_p	0.6 kV	1.3 kV	1.5 kV	1.5 kV	1.8 kV
Response Time	t_A	< 25 ns				
Back-Up Fuse (max)		125 A gL / gG				
Short-Circuit Current Rating (AC)	I_{SCCR}	10 kA				
TOV Withstand 5s	U_T	180V	335V	335V	335V	580V
TOV 120min	U_T	230V	440V	440V	440V	765V
	mode	Withstand	Safe Fail	Safe Fail	Safe Fail	Safe Fail
Mechanical & Environmental						
Operating Temperature Range	T_a	-40°F to +158°F [-40°C to +70°C]				
Permissible Operating Humidity	RH	5%...95%				
Atmospheric pressure and altitude		80k Pa ... 106k Pa / -500 m.....2000 m				
Terminal Screw Torque	M_{max}	39.9 lbf-in [4.5 Nm]				
Conductor Cross Section (max)		2 AWG (Solid, Stranded) / 4 AWG (Flexible) 35 mm ² (Solid, Stranded) / 25 mm ² (Flexible)				
Mounting		35 mm DIN Rail, EN 60715				
Degree of Protection		IP 20 (built-in)				
Housing Material		Thermoplastic: Extinguishing Degree UL 94 V-0				
Thermal Protection		Yes				
Operating State / Fault Indication		Green ok / Red defect				
Remote Contacts (RC)		Optional				
RC Switching Capacity		AC: 250V / 0.5 A; DC: 250V / 0.1 A;125V / 0.2 A;75V / 0.5 A				
RC Conductor Cross Section (max)		16 AWG (Solid) / 1.5 mm ² (Solid)				

LY1-D20M/4(S)

Pluggable Multi-Pole SPD



Internal Configuration

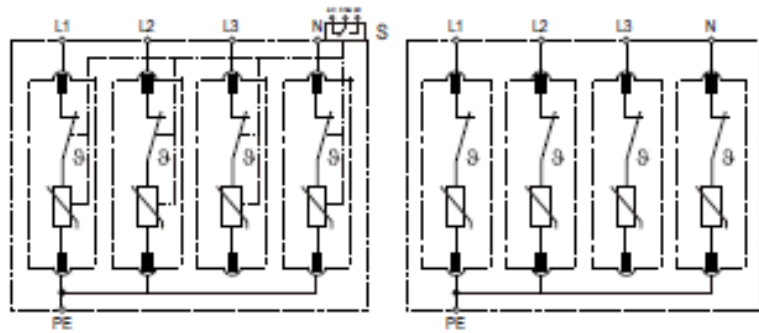

Dimensions & Packaging

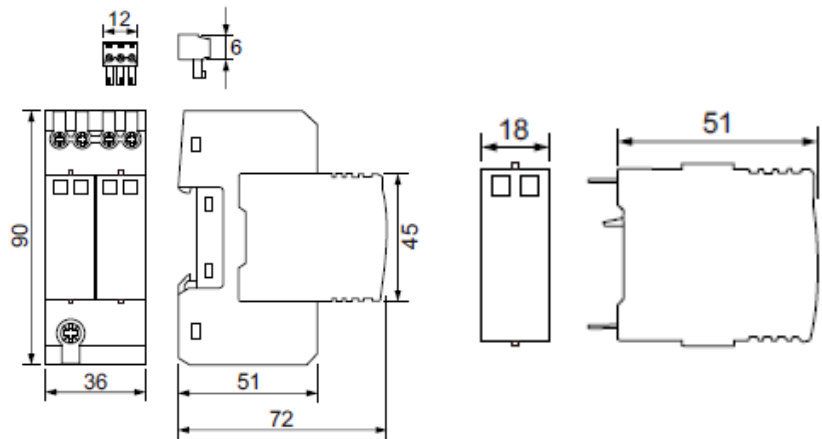

Connection Diagram

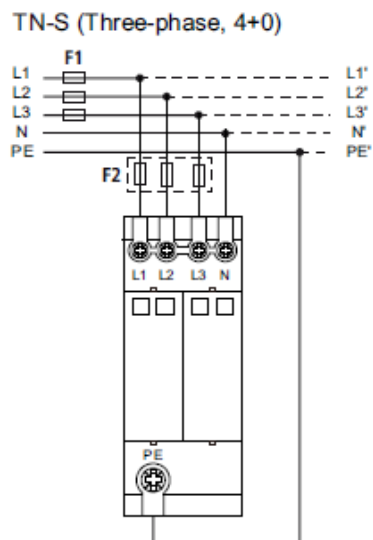

LY1-D20M/1(S)+1 Pluggable Single-Pole SPD



Class II • Class III • Type 2 • Type 3

Location of Use: Sub-Distribution Boards
 Mode of Protection: L-N, N-PE
 Surge Ratings: $I_n = 10 \text{ kA}$ (8/20 μs)
 IEC/EN/UL Category: Class II+III / Type 2+3
 Protective Elements: High Energy MOV and GDT
 Housing: Pluggable Design
 Compliance: IEC 61643-11:2011
 EN 61643-11:2012

■ Technical Data

IEC Electrical		75	150	275	320	385	440
Nominal AC Voltage (50/60Hz)		60 V	120 V	230 V	230 V	230 V	400 V
Maximum Continuous Operating Voltage (AC)	(L-N) U_c	75 V	150 V	275V	320 V	385 V	440 V
	(N-PE) U_c	255V					
Nominal Discharge Current (8/20 μs)	(L-N) / (N-PE) I_n	10kV / 10kA					
Maximum Discharge Current (8/20 μs)	(L-N) / (N-PE) I_{max}	20 kA / 20 kA					
Voltage Protection Level	(L-N) / (N-PE) U_p	0.2kV/1.5kV	0.6kV/1.5kV	1.3kV/1.5kV	1.5kV/1.5kV	1.5kV/1.5kV	1.8kV/1.5kV
Follow Current Interrupt Rating	(N-PE) I_{fi}	100A _{RMS}					
Response Time	(L-N) / (N-PE) t_A	< 25 ns / < 100 ns					
Back-Up Fuse (max)		125 A gL / gG					
Short-Circuit Current Rating (AC)	(L-N) I_{SCCR}	10 kA					
TOV Withstand 5s	(L-N) U_T	90V	180V	335V	335V	335V	580V
TOV 120min	(L-N) U_T	115V	230V	440V	440V	440V	765V
		mode	Withstand	Withstand	Safe Fail	Safe Fail	Safe Fail
TOV Withstand 200ms	(N-PE) U_T	1200V					
Mechanical & Environmental							
Operating Temperature Range	T_a	-40°F to +158°F [-40°C to +70°C]					
Permissible Operating Humidity	RH	5%...95%					
Atmospheric pressure and altitude		80k Pa ... 106k Pa / -500 m.....2000 m					
Terminal Screw Torque	M_{max}	39.9 lbf-in [4.5 Nm]					
Conductor Cross Section (max)		2 AWG (Solid, Stranded) / 4 AWG (Flexible)					
		35 mm ² (Solid, Stranded) / 25 mm ² (Flexible)					
Mounting		35 mm DIN Rail, EN 60715					
Degree of Protection		IP 20 (built-in)					
Housing Material		Thermoplastic: Extinguishing Degree UL 94 V-0					
Thermal Protection		Yes					
Operating State / Fault Indication		Green ok / Red defect					
Remote Contacts (RC)		Optional					
RC Switching Capacity		AC: 250V / 0.5 A; DC: 250V / 0.1 A; 125 V / 0.2 A; 75 V / 0.5 A					
RC Conductor Cross Section (max)		16 AWG (Solid) / 1.5 mm ² (Solid)					

LY1-D20M/1(S)+1

Pluggable Single-Pole SPD



Internal Configuration

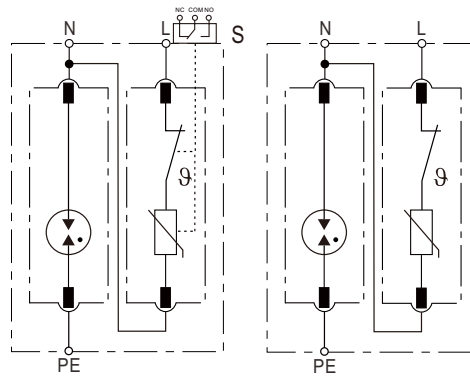

Dimensions & Packaging

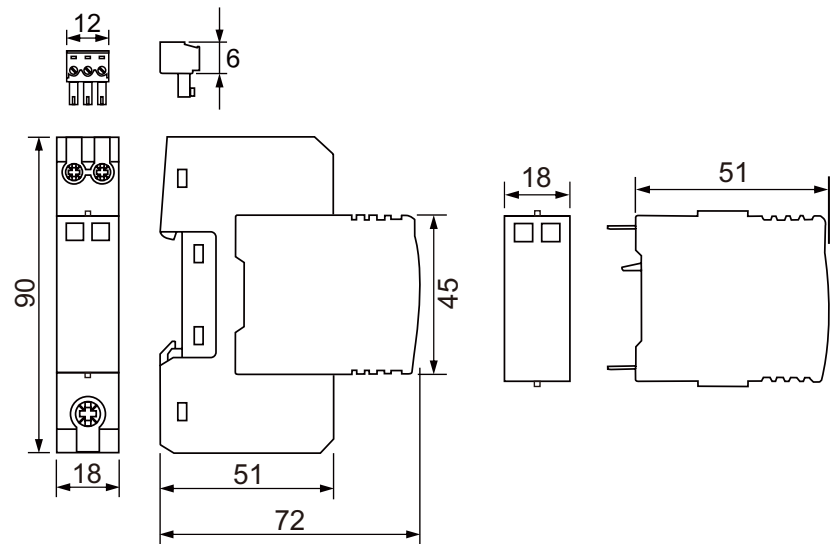

Connection Diagram

TN-S, TT (Single-phase, 1+1)

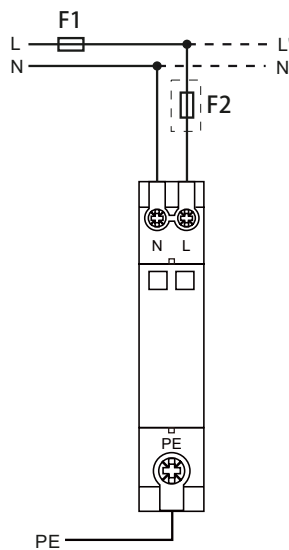

LY1-D20M/3(S)+1 Pluggable Multi-Pole SPD



Class II • Class III • Type 2 • Type 3

Location of Use: Sub-Distribution Boards
 Mode of Protection: L-N, N-PE
 Surge Ratings: $I_n = 10 \text{ kA}$ (8/20 μs)
 IEC/EN/UL Category: Class II+III / Type 2+3
 Protective Elements: High Energy MOV and GDT
 Housing: Pluggable Design
 Compliance: IEC 61643-11:2011
 EN 61643-11:2012

■ Technical Data

IEC Electrical		150	275	320	385	440
Nominal AC Voltage (50/60Hz)		120 V	230 V	230 V	230 V	400 V
Maximum Continuous Operating Voltage (AC)	(L-N) U_c	150 V	275V	320 V	385 V	440 V
	(N-PE) U_c			255V		
Nominal Discharge Current (8/20 μs)	(L-N) / (N-PE) I_n			10 kA / 10kA		
Maximum Discharge Current (8/20 μs)	(L-N) / (N-PE) I_{max}			20 kA / 20 kA		
Voltage Protection Level	(L-N) / (N-PE) U_p	0.6kV/1.5kV	1.3kV/1.5kV	1.5kV/1.5kV	1.5kV/1.5kV	1.8kV/1.5kV
Follow Current Interrupt Rating	(N-PE) I_{fi}			100A _{RMS}		
Response Time	(L-N) / (N-PE) t_A			< 25 ns / < 100 ns		
Back-Up Fuse (max)				125 A gL / gG		
Short-Circuit Current Rating (AC)	(L-N) I_{SCCR}			10 kA		
TOV Withstand 5s	(L-N) U_T	180V	335V	335V	335V	580V
TOV 120min	(L-N) U_T	230V	440V	440V	440V	765V
		mode	Withstand	Safe Fail	Safe Fail	Safe Fail
TOV Withstand 200ms	(N-PE) U_T			1200V		
Mechanical & Environmental						
Operating Temperature Range	T_a	-40°F to +158°F [-40°C to +70°C]				
Permissible Operating Humidity	RH	5%...95%				
Atmospheric pressure and altitude		80k Pa ... 106k Pa / -500 m.....2000 m				
Terminal Screw Torque	M_{max}	39.9 lbf-in [4.5 Nm]				
Conductor Cross Section (max)		2 AWG (Solid, Stranded) / 4 AWG (Flexible)				
		35 mm ² (Solid, Stranded) / 25 mm ² (Flexible)				
Mounting		35 mm DIN Rail, EN 60715				
Degree of Protection		IP 20 (built-in)				
Housing Material		Thermoplastic: Extinguishing Degree UL 94 V-0				
Thermal Protection		Yes				
Operating State / Fault Indication		Green ok / Red defect				
Remote Contacts (RC)		Optional				
RC Switching Capacity		AC: 250V / 0.5 A; DC: 250V / 0.1 A; 125 V / 0.2 A; 75 V / 0.5 A				
RC Conductor Cross Section (max)		16 AWG (Solid) / 1.5 mm ² (Solid)				

LY1-D20M/3(S)+1

Pluggable Multi-Pole SPD



Internal Configuration

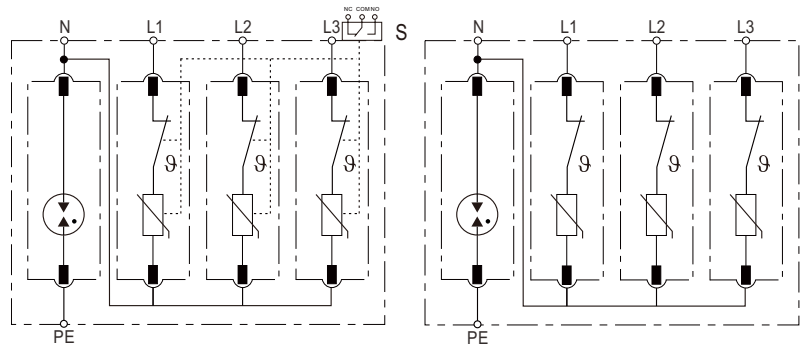

Dimensions & Packaging

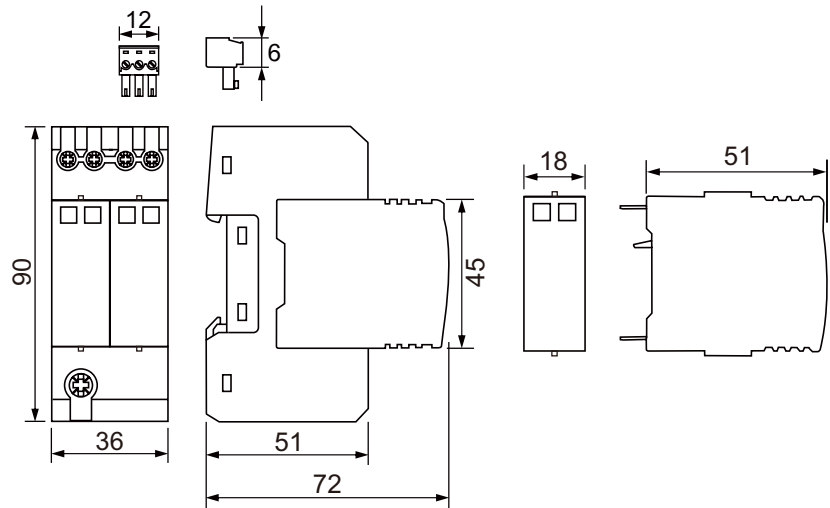

Connection Diagram

TN-S, TT (Three-phase, 3+1)

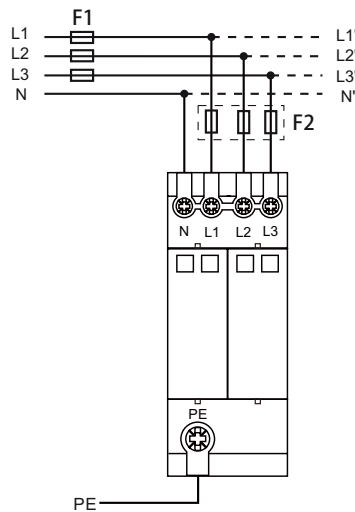



Class I • Class II • Type 1 • Type 2

Location of Use: Sub-Distribution Boards

Mode of Protection: L-PE, N-PE

Surge Ratings: In = 10 kA (8/20 µs)

IEC/EN/UL Category: Class I+II / Type 1+2

Protective Elements: High Energy MOV

Housing: Pluggable Design

Compliance: IEC 61643-11:2011

EN 61643-11:2012

■ Technical Data

IEC Electrical		75	150	275	320	385	440
Nominal AC Voltage (50/60Hz)	U_o / U_n	60 V	120 V	230 V	230 V	230 V	400 V
Maximum Continuous Operating Voltage (AC)	U_c	75 V	150 V	275V	320 V	385 V	440 V
Nominal Discharge Current (8/20 µs)	I_n	20 kA	20 kA	20 kA	20 kA	20 kA	20 kA
Maximum Discharge Current (8/20 µs)	I_{max}	40 kA	40 kA	40 kA	40 kA	40 kA	40 kA
Impulse Discharge Current (10/350 µs)	I_{imp}	7 kA					
Voltage Protection Level	U_p	0.4 kV	1 kV	1.5 kV	1.6 kV	1.8 kV	2 kV
Response Time	t_A	< 25 ns					
Back-Up Fuse (max)		63 A gL / gG					
Short-Circuit Current Rating (AC)	I_{SCCR}	25 kA					
TOV Withstand 5s	U_T	90V	180V	335V	335V	335V	580V
TOV 120min	U_T	115V	230V	440V	440V	440V	765V
	mode	Withstand	Withstand	Safe Fail	Safe Fail	Safe Fail	Safe Fail
Mechanical & Environmental							
Operating Temperature Range	T_a	-40°F to +158°F [-40°C to +70°C]					
Permissible Operating Humidity	RH	5%...95%					
Atmospheric pressure and altitude		80k Pa ... 106k Pa / -500 m.....2000 m					
Terminal Screw Torque	(L, N)	M_{max} 13.3 lbf·in [1.5 Nm]					
	(PE)	39.9 lbf·in [4.5 Nm]					
Conductor Cross Section (max)	(L, N)	5 AWG (Solid, Stranded) / 7 AWG (Flexible)					
		16 mm ² (Solid, Stranded) / 10 mm ² (Flexible)					
Conductor Cross Section	(PE)	2 AWG (Solid, Stranded) / 4 AWG (Flexible)					
		35 mm ² (Solid, Stranded) / 25 mm ² (Flexible)					
Mounting		35 mm DIN Rail, EN 60715					
Degree of Protection		IP 20 (built-in)					
Housing Material		Thermoplastic: Extinguishing Degree UL 94 V-0					
Thermal Protection		Yes					
Operating State / Fault Indication		Green ok / Red defect					
Remote Contacts (RC)		Optional					
RC Switching Capacity		AC: 250V / 0.5 A; DC: 250V / 0.1 A; 125V / 0.2 A; 75V / 0.5 A					
RC Conductor Cross Section (max)		16 AWG (Solid) / 1.5 mm ² (Solid)					
RC Terminal Screw Torque		2.2 lbf·in [0.25 Nm]					

LY1-C40M/2(S)

Pluggable Single-Pole SPD



Internal Configuration

Legend

- L Line
- N Neutral
- PE Protective Earth
- S Signalling Contacts Optional

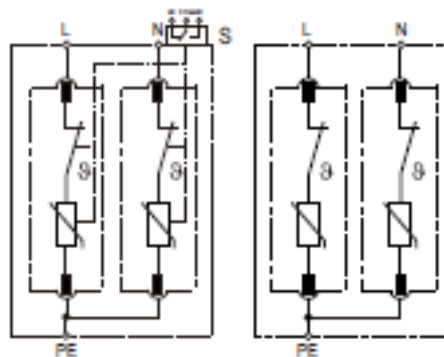

Dimensions & Packaging

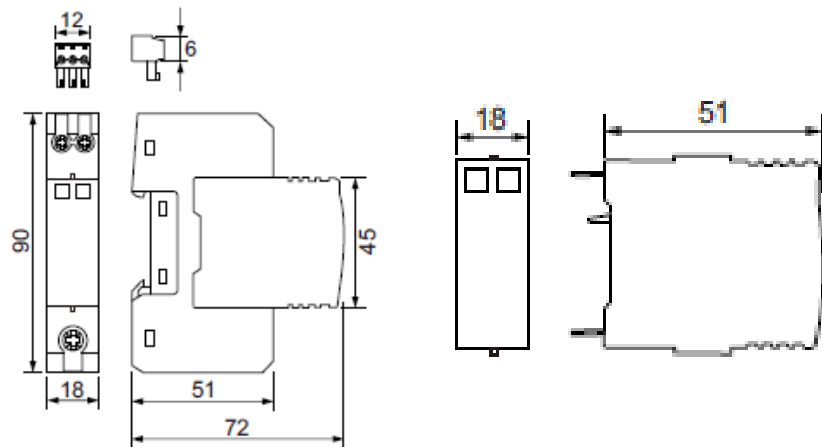

Connection Diagram

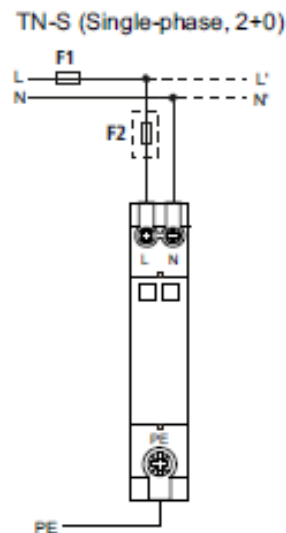

LY1-C40M/4(S) Pluggable Multi-Pole SPD



Class I • Class II • Type 1 • Type 2

Location of Use: Sub-Distribution Boards

Mode of Protection: L-PE, N-PE

Surge Ratings: $I_n = 20 \text{ kA}$ (8 / 20 μs)

IEC/EN/UL Category: Class I+II / Type 1+2

Protective Elements: High Energy MOV

Housing: Pluggable Design

Compliance: IEC 61643-11:2011

EN 61643-11:2012

■ Technical Data

IEC Electrical		150	275	320	385	440
Nominal AC Voltage (50/60Hz)	U_o / U_n	120 V	230 V	230 V	230 V	400 V
Maximum Continuous Operating Voltage (AC)	U_c	150 V	275V	320 V	385 V	440 V
Nominal Discharge Current (8/20 μs)	I_n	20 kA	20 kA	20 kA	20 kA	20 kA
Maximum Discharge Current (8/20 μs)	I_{max}	40 kA	40 kA	40 kA	40 kA	40 kA
Impulse Discharge Current (10/350 μs)	I_{imp}			7 kA		
Voltage Protection Level	U_p	1 kV	1.5 kV	1.6 kV	1.8 kV	2 kV
Response Time	t_A			< 25 ns		
Back-Up Fuse (max)				63 A gL / gG		
Short-Circuit Current Rating (AC)	I_{SCCR}			25 kA		
TOV Withstand 5s	U_T	180V	335V	335V	335V	580V
TOV 120min	U_T	230V	440V	440V	440V	765V
	mode	Withstand	Safe Fail	Safe Fail	Safe Fail	Safe Fail
Mechanical & Environmental						
Operating Temperature Range	T_a	-40°F to +158°F [-40°C to +70°C]				
Permissible Operating Humidity	RH	5%...95%				
Atmospheric pressure and altitude		80k Pa ... 106k Pa / -500 m.....2000 m				
Terminal Screw Torque	(L, N)	13.3 lbf-in [1.5 Nm]				
	(PE)	39.9 lbf-in [4.5 Nm]				
Conductor Cross Section (max)	(L, N)	5 AWG (Solid, Stranded) / 7 AWG (Flexible)				
		16 mm ² (Solid, Stranded) / 10 mm ² (Flexible)				
Conductor Cross Section	(PE)	2 AWG (Solid, Stranded) / 4 AWG (Flexible)				
		35 mm ² (Solid, Stranded) / 25 mm ² (Flexible)				
Mounting		35 mm DIN Rail, EN 60715				
Degree of Protection		IP 20 (built-in)				
Housing Material		Thermoplastic: Extinguishing Degree UL 94 V-0				
Thermal Protection		Yes				
Operating State / Fault Indication		Green ok / Red defect				
Remote Contacts (RC)		Optional				
RC Switching Capacity		AC: 250V / 0.5 A; DC: 250V / 0.1 A; 125V / 0.2 A; 75V / 0.5 A				
RC Conductor Cross Section (max)		16 AWG (Solid) / 1.5 mm ² (Solid)				
RC Terminal Screw Torque		2.2 lbf-in [0.25 Nm]				

LY1-C40M/4(S)

Pluggable Multi-Pole SPD



Internal Configuration

Legend

- L Line
- N Neutral
- PE Protective Earth
- S Signalling Contacts Optional

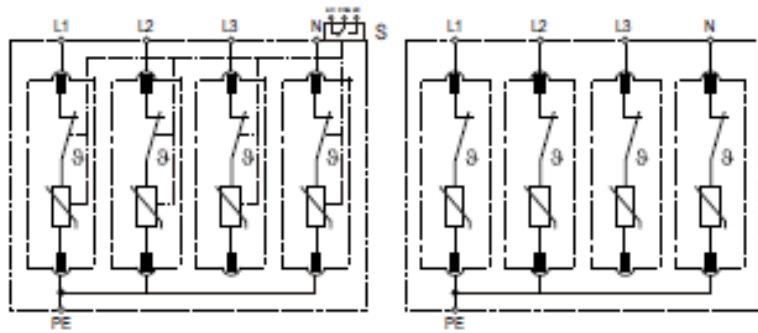

Dimensions & Packaging

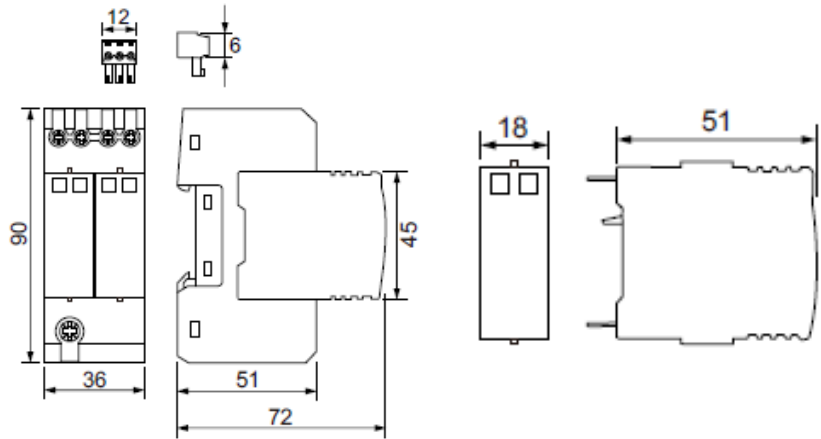

Connection Diagram

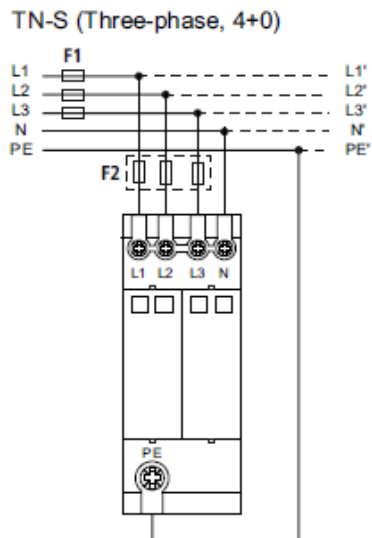



Class I • Class II • Type 1 • Type 2

Location of Use: Sub-Distribution Boards
 Mode of Protection: L-N, N-PE
 Surge Ratings: $I_n = 20 \text{ kA}$ (8/20 μs)
 IEC/EN/UL Category: Class I+II / Type 1+2
 Protective Elements: High Energy MOV and GDT
 Housing: Pluggable Design
 Compliance: IEC 61643-11:2011
 EN 61643-11:2012

■ Technical Data

IEC Electrical		75	150	275	320	385	440
Nominal AC Voltage (50/60Hz)		60 V	120 V	230 V	230 V	230 V	400 V
Maximum Continuous Operating Voltage (AC)	(L - N) U_c	75 V	150 V	275V	320 V	385 V	440 V
	(N - PE) U_c	255V					
Nominal Discharge Current (8/20 μs)	(L - N) / (N - PE) I_n	20 kA / 20 kA					
Maximum Discharge Current (8/20 μs)	(L - N) / (N - PE) I_{max}	40 kA / 40 kA					
Impulse Discharge Current (10/350 μs)	(L - N) / (N - PE) I_{imp}	7 kA/25 kA					
Voltage Protection Level	(L - N) / (N - PE) U_p	0.4kV / 1.5kV	1.0kV / 1.5kV	1.5kV / 1.5kV	1.6kV / 1.5kV	1.8kV / 1.5kV	2.0kV / 1.5kV
Follow Current Interrupt Rating	(N - PE) I_{fi}	100A _{RMS}					
Response Time	(L - N) / (N - PE) t_A	< 25 ns / < 100 ns					
Back-Up Fuse (max)		63 A gL / gG					
Short-Circuit Current Rating (AC)	(L - N) I_{SCCR}	25 kA					
TOV Withstand 5s	(L - N) U_T	90V	180V	335V	335V	335V	580V
TOV 120min	(L - N) U_T	115V	230V	440V	440V	440V	765V
	mode	Withstand	Withstand	Safe Fail	Safe Fail	Safe Fail	Safe Fail
TOV Withstand 200ms	(N - PE) U_T	1200V					
Mechanical & Environmental							
Operating Temperature Range	T_a	-40°F to +158°F [-40°C to +70°C]					
Permissible Operating Humidity	RH	5%...95%					
Atmospheric pressure and altitude		80k Pa ... 106k Pa / -500 m.....2000 m					
Terminal Screw Torque	(L, N) M_{max}	39.9 lbf-in [4.5 Nm]					
	(PE) M_{max}	39.9 lbf-in [4.5 Nm]					
Conductor Cross Section	(L, N)	5 AWG (Solid, Stranded) / 7 AWG (Flexible)					
		16 mm ² (Solid, Stranded) / 10 mm ² (Flexible)					
	(PE)	2 AWG (Solid, Stranded) / 4 AWG (Flexible)					
		35 mm ² (Solid, Stranded) / 25 mm ² (Flexible)					
Mounting		35 mm DIN Rail, EN 60715					
Degree of Protection		IP 20 (built-in)					
Housing Material		Thermoplastic: Extinguishing Degree UL 94 V-0					
Thermal Protection		Yes					
Operating State / Fault Indication		Green ok / Red defect					
Remote Contacts (RC)		Optional					
RC Switching Capacity		AC: 250V / 0.5 A; DC: 250V / 0.1 A; 125 V / 0.2 A; 75 V / 0.5 A					
RC Conductor Cross Section (max)		16 AWG (Solid) / 1.5 mm ² (Solid)					
RC Terminal Screw Torque		2.2 lbf-in [0.25 Nm]					

LY1-C40M/1(S)+1

Pluggable Single-Pole SPD



Internal Configuration

Legend

- L Line
- N Neutral
- PE Protective Earth
- S Signalling Contacts Optional

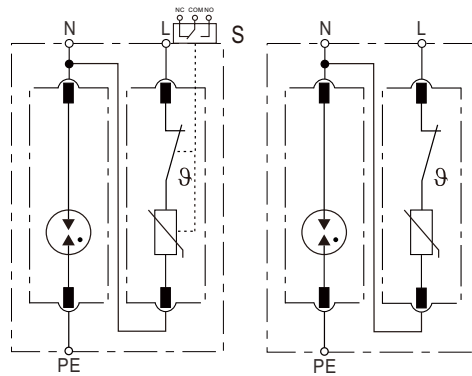

Dimensions & Packaging

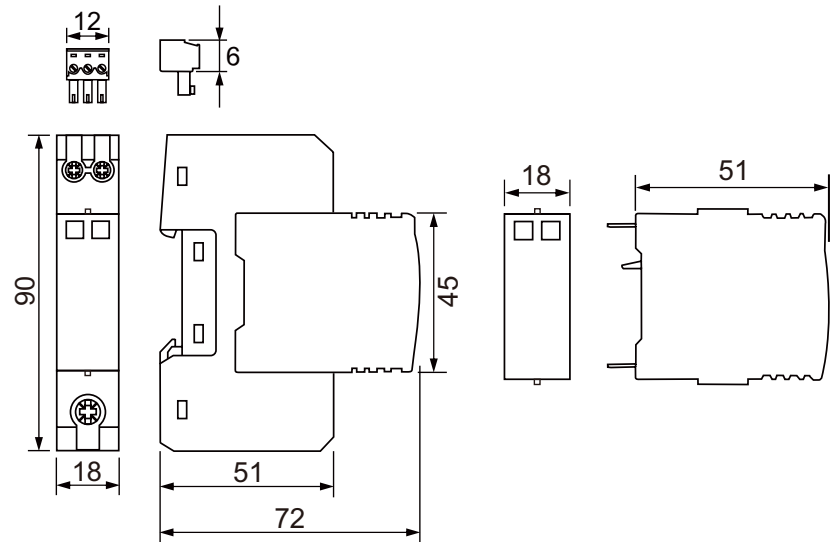

Connection Diagram

TN-S, TT (Single-phase, 1+1)

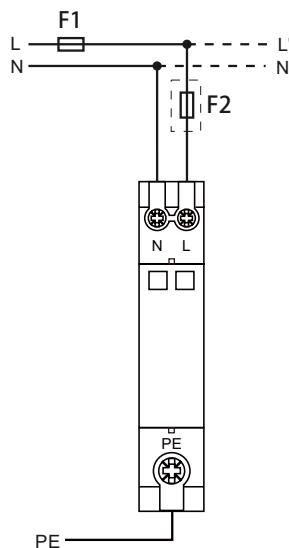



Class I • Class II • Type 1 • Type 2

Location of Use: Sub-Distribution Boards
 Mode of Protection: L-N, N-PE
 Surge Ratings: $I_n = 20 \text{ kA}$ (8/20 μs)
 IEC/EN/UL Category: Class I+II / Type 1+2
 Protective Elements: High Energy MOV and GDT
 Housing: Pluggable Design
 Compliance: IEC 61643-11:2011
 EN 61643-11:2012

■ Technical Data

IEC Electrical		150	275	320	385	440
Nominal AC Voltage (50/60Hz)		120 V	230 V	230 V	230 V	400 V
Maximum Continuous Operating Voltage (AC)	(L - N) U_c	150 V	275V	320 V	385 V	440 V
	(N - PE) U_c			255 V		
Nominal Discharge Current (8/20 μs)	(L - N) / (N - PE) I_n			20 kA / 20 kA		
Maximum Discharge Current (8/20 μs)	(L - N) / (N - PE) I_{max}			40 kA / 40 kA		
Impulse Discharge Current (10/350 μs)	(L - N) / (N - PE) I_{imp}			7 kA/25 kA		
Voltage Protection Level	(L - N) / (N - PE) U_p	1.0kV / 1.5kV	1.5kV / 1.5kV	1.6kV / 1.5kV	1.8kV / 1.5kV	2.0kV / 1.5kV
Follow Current Interrupt Rating	(N - PE) I_f			100 A _{RMS}		
Response Time	(L - N) / (N - PE) t_A			< 25 ns / < 100 ns		
Back-Up Fuse (max)				63 AgL / gG		
Short-Circuit Current Rating (AC)	(L - N) I_{SCCR}			25 kA		
TOV Withstand 5s	(L - N) U_T	180V	335V	335V	335V	580V
TOV 120min	(L - N) U_T	230V	440V	440V	440V	765V
	mode	Withstand	Safe Fail	Safe Fail	Safe Fail	Safe Fail
TOV Withstand 200ms	(N - PE) U_T			1200V		
Mechanical & Environmental						
Operating Temperature Range	T_a	-40°F to +158°F [-40°C to +70°C]				
Permissible Operating Humidity	RH	5%...95%				
Atmospheric pressure and altitude		80k Pa ... 106k Pa / -500 m.....2000 m				
Terminal Screw Torque	(L, N) M_{max}					
	(PE) M_{max}	39.9 lbf-in [4.5 Nm]				
Conductor Cross Section	(L, N)	5 AWG (Solid, Stranded) / 7 AWG (Flexible)				
		16 mm ² (Solid, Stranded) / 10 mm ² (Flexible)				
	(PE)	2 AWG (Solid, Stranded) / 4 AWG (Flexible)				
		35 mm ² (Solid, Stranded) / 25 mm ² (Flexible)				
Mounting		35 mm DIN Rail, EN 60715				
Degree of Protection		IP 20 (built-in)				
Housing Material		Thermoplastic: Extinguishing Degree UL 94 V-0				
Thermal Protection		Yes				
Operating State / Fault Indication		Green ok / Red defect				
Remote Contacts (RC)		Optional				
RC Switching Capacity		AC: 250V / 0.5 A; DC: 250V / 0.1 A; 125 V / 0.2 A; 75 V / 0.5 A				
RC Conductor Cross Section (max)		16 AWG (Solid) / 1.5 mm ² (Solid)				
RC Terminal Screw Torque		2.2 lbf-in [0.25 Nm]				

LY1-C40M/3(S)+1

Pluggable Multi-Pole SPD



Internal Configuration

Legend

- L Line
- N Neutral
- PE Protective Earth
- S Signalling Contacts Optional

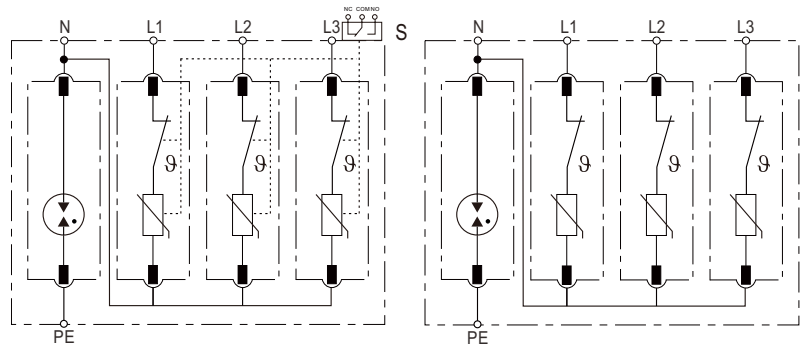

Dimensions & Packaging

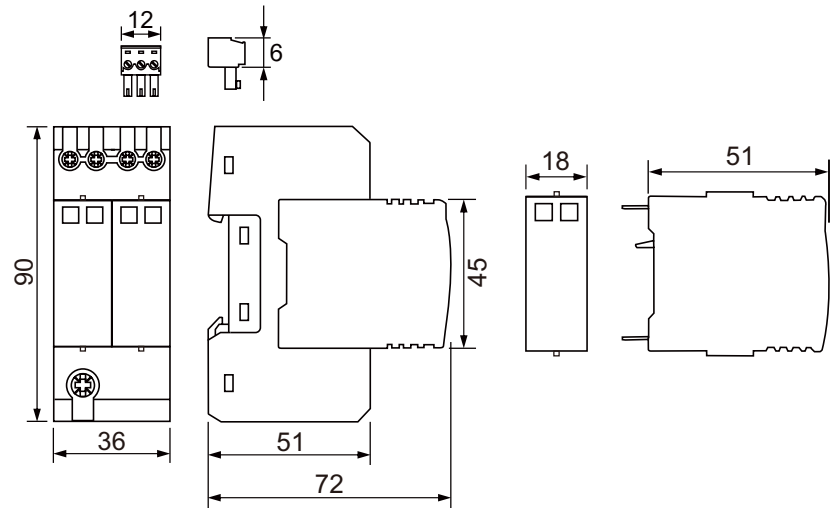

Connection Diagram

TN-S, TT (Three-phase, 3+1)

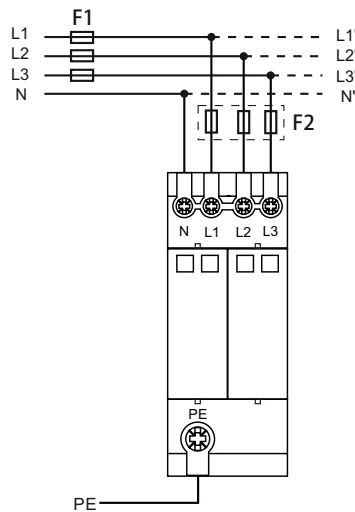

LY1-B65/1(S) Pluggable Single-Pole SPD



Class I • Class II • Type 1 • Type 2

Location of Use: Sub-Distribution Boards
 Mode of Protection: L-PE, N-PE
 Surge Ratings: $I_n = 10 \text{ kA}$ (8/20 μs)
 IEC/EN/UL Category: Class I+II / Type 1+2
 Protective Elements: High Energy MOV
 Housing: Pluggable Design
 Compliance: IEC 61643-11:2011
 EN 61643-11:2012

■ Technical Data

IEC Electrical		75	150	275	320	385	440
Nominal AC Voltage (50/60Hz)	U_o / U_n	60 V	120 V	230 V	230 V	230 V	400 V
Maximum Continuous Operating Voltage (AC)	U_c	75 V	150 V	275V	320 V	385 V	440 V
Nominal Discharge Current (8/20 μs)	I_n	35 kA	35 kA	35 kA	35 kA	35 kA	35 kA
Maximum Discharge Current (8/20 μs)	I_{max}	65 kA	65 kA	65 kA	65 kA	65 kA	65 kA
Impulse Discharge Current (10/350 μs)	I_{imp}	7kA					
Voltage Protection Level	U_p	0.8 kV	1.2 kV	1.5 kV	1.8 kV	2 kV	2.2 kV
Response Time	t_A	< 25 ns					
Back-Up Fuse (max)		125 A gL / gG					
Short-Circuit Current Rating (AC)	I_{SCCR}	35 kA / 50 kA					
TOV Withstand 5s	U_T	90V	180V	335V	335V	335V	580V
TOV 120min	U_T	115V	230V	440V	440V	440V	765V
	mode	Withstand	Withstand	Safe Fail	Safe Fail	Safe Fail	Safe Fail
Mechanical & Environmental							
Operating Temperature Range	T_a	-40°F to +158°F [-40°C to +70°C]					
Permissible Operating Humidity	RH	5%...95%					
Atmospheric pressure and altitude		80k Pa ... 106k Pa / -500 m.....2000 m					
Terminal Screw Torque	M_{max}	39.9 lbf·in [4.5 Nm]					
Conductor Cross Section (max)		2 AWG (Solid, Stranded) / 4 AWG (Flexible) 35 mm ² (Solid, Stranded) / 25 mm ² (Flexible)					
Mounting		35 mm DIN Rail, EN 60715					
Degree of Protection		IP 20 (built-in)					
Housing Material		Thermoplastic: Extinguishing Degree UL 94 V-0					
Thermal Protection		Yes					
Operating State / Fault Indication		Green ok / Red defect					
Remote Contacts (RC)		Optional					
RC Switching Capacity		AC: 250V / 0.5 A; DC: 250V / 0.1 A; 125V / 0.2 A; 75V / 0.5 A					
RC Conductor Cross Section (max)		16 AWG (Solid) / 1.5 mm ² (Solid)					

LY1-B65/1(S)

Pluggable Single-Pole SPD



Internal Configuration

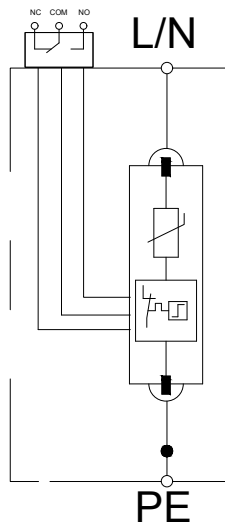

Dimensions & Packaging

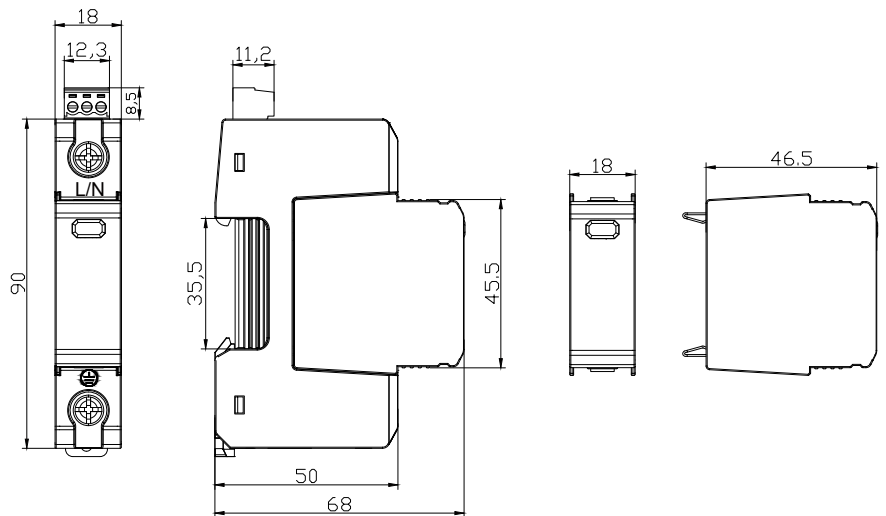

Connection Diagram

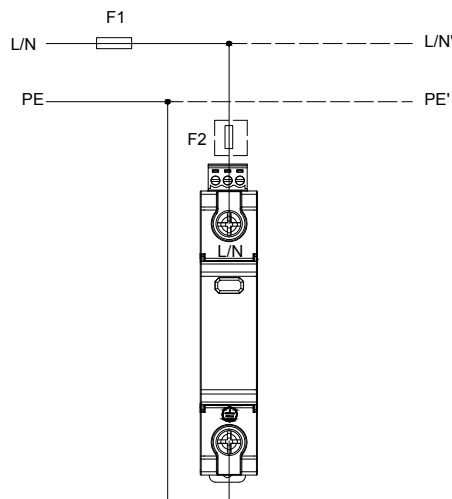

LY1-B65/2(S) Pluggable Single-Pole SPD



Class I • Class II • Type 1 • Type 2

Location of Use: Sub-Distribution Boards

Mode of Protection: L-PE, N-PE

Surge Ratings: $I_n = 10 \text{ kA}$ (8/20 μs)

IEC/EN/UL Category: Class I+II / Type 1+2

Protective Elements: High Energy MOV

Housing: Pluggable Design

Compliance: IEC 61643-11:2011

EN 61643-11:2012

■ Technical Data

IEC Electrical		75	150	275	320	385	440
Nominal AC Voltage (50/60Hz)	U_o / U_n	60 V	120 V	230 V	230 V	230 V	400 V
Maximum Continuous Operating Voltage (AC)	U_c	75 V	150 V	275V	320 V	385 V	440 V
Nominal Discharge Current (8/20 μs)	I_n	35 kA	35 kA	35 kA	35 kA	35 kA	35 kA
Maximum Discharge Current (8/20 μs)	I_{max}	65 kA	65 kA	65 kA	65 kA	65 kA	65 kA
Impulse Discharge Current (10/350 μs)	I_{imp}	7kA					
Voltage Protection Level	U_p	0.8 kV	1.2 kV	1.5 kV	1.8 kV	2 kV	2.2 kV
Response Time	t_A	< 25 ns					
Back-Up Fuse (max)		125 A gL / gG					
Short-Circuit Current Rating (AC)	I_{SCCR}	35 kA / 50 kA					
TOV Withstand 5s	U_T	90V	180V	335V	335V	335V	580V
TOV 120min	U_T	115V	230V	440V	440V	440V	765V
	mode	Withstand	Withstand	Safe Fail	Safe Fail	Safe Fail	Safe Fail
Mechanical & Environmental							
Operating Temperature Range	T_a	-40°F to +158°F [-40°C to +70°C]					
Permissible Operating Humidity	RH	5%...95%					
Atmospheric pressure and altitude		80k Pa ... 106k Pa / -500 m.....2000 m					
Terminal Screw Torque	M_{max}	39.9 lbf·in [4.5 Nm]					
Conductor Cross Section (max)		2 AWG (Solid, Stranded) / 4 AWG (Flexible) 35 mm ² (Solid, Stranded) / 25 mm ² (Flexible)					
Mounting		35 mm DIN Rail, EN 60715					
Degree of Protection		IP 20 (built-in)					
Housing Material		Thermoplastic: Extinguishing Degree UL 94 V-0					
Thermal Protection		Yes					
Operating State / Fault Indication		Green ok / Red defect					
Remote Contacts (RC)		Optional					
RC Switching Capacity		AC: 250V / 0.5 A; DC: 250V / 0.1 A; 125V / 0.2 A; 75V / 0.5 A					
RC Conductor Cross Section (max)		16 AWG (Solid) / 1.5 mm ² (Solid)					

LY1-B65/2(S)

Pluggable Single-Pole SPD



Internal Configuration

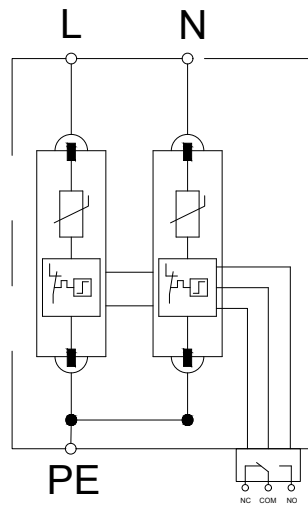

Dimensions & Packaging

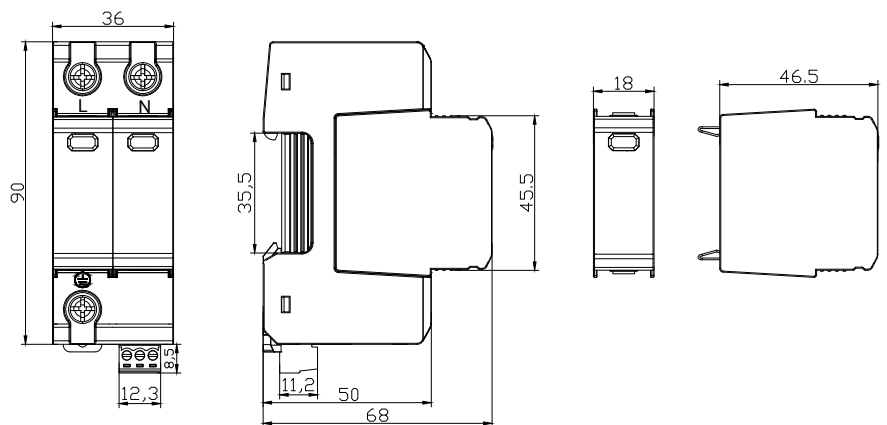

Connection Diagram

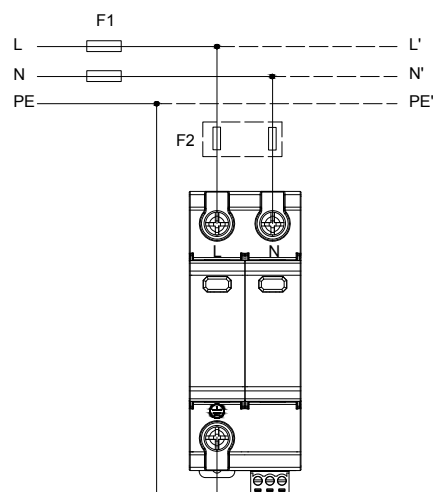

LY1-B65/3(S) Pluggable Multi-Pole SPD



Class I • Class II • Type 1 • Type 2

Location of Use: Sub-Distribution Boards

Mode of Protection: L-PE, N-PE

Surge Ratings: $I_n = 10 \text{ kA}$ (8/20 μs)

IEC/EN/UL Category: Class I+II / Type 1+2

Protective Elements: High Energy MOV

Housing: Pluggable Design

Compliance: IEC 61643-11:2011

EN 61643-11:2012

■ Technical Data

IEC Electrical		150	275	320	385	440
Nominal AC Voltage (50/60Hz)	U_o / U_n	120 V	230 V	230 V	230 V	400 V
Maximum Continuous Operating Voltage (AC)	U_c	150 V	275V	320 V	385 V	440 V
Nominal Discharge Current (8/20 μs)	I_n	35 kA	35 kA	35 kA	35 kA	35 kA
Maximum Discharge Current (8/20 μs)	I_{max}	65 kA	65 kA	65 kA	65 kA	65 kA
Impulse Discharge Current (10/350 μs)	I_{imp}			7kA		
Voltage Protection Level	U_p	1.2 kV	1.5 kV	1.8 kV	2 kV	2.2 kV
Response Time	t_A			< 25 ns		
Back-Up Fuse (max)				125 A gL / gG		
Short-Circuit Current Rating (AC)	I_{SCCR}			35 kA / 50 kA		
TOV Withstand 5s	U_T	180V	335V	335V	335V	580V
TOV 120min	U_T	230V	440V	440V	440V	765V
	mode	Withstand	Safe Fail	Safe Fail	Safe Fail	Safe Fail
Mechanical & Environmental						
Operating Temperature Range	T_a	-40°F to +158°F [-40°C to +70°C]				
Permissible Operating Humidity	RH	5%...95%				
Atmospheric pressure and altitude		80k Pa ... 106k Pa / -500 m.....2000 m				
Terminal Screw Torque	M_{max}	39.9 lbf-in [4.5 Nm]				
Conductor Cross Section (max)		2 AWG (Solid, Stranded) / 4 AWG (Flexible) 35 mm ² (Solid, Stranded) / 25 mm ² (Flexible)				
Mounting		35 mm DIN Rail, EN 60715				
Degree of Protection		IP 20 (built-in)				
Housing Material		Thermoplastic: Extinguishing Degree UL 94 V-0				
Thermal Protection		Yes				
Operating State / Fault Indication		Green ok / Red defect				
Remote Contacts (RC)		Optional				
RC Switching Capacity		AC: 250V / 0.5 A; DC: 250V / 0.1 A;125V / 0.2 A;75V / 0.5 A				
RC Conductor Cross Section (max)		16 AWG (Solid) / 1.5 mm ² (Solid)				

LY1-B65/3(S)

Pluggable Multi-Pole SPD



Internal Configuration

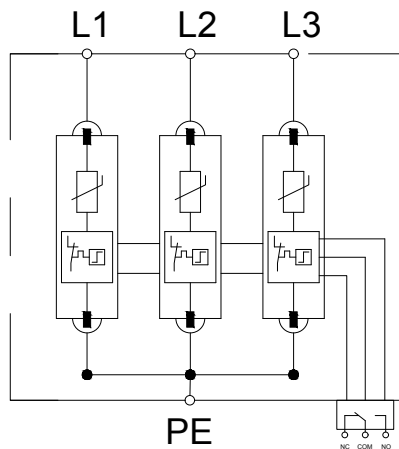

Dimensions & Packaging

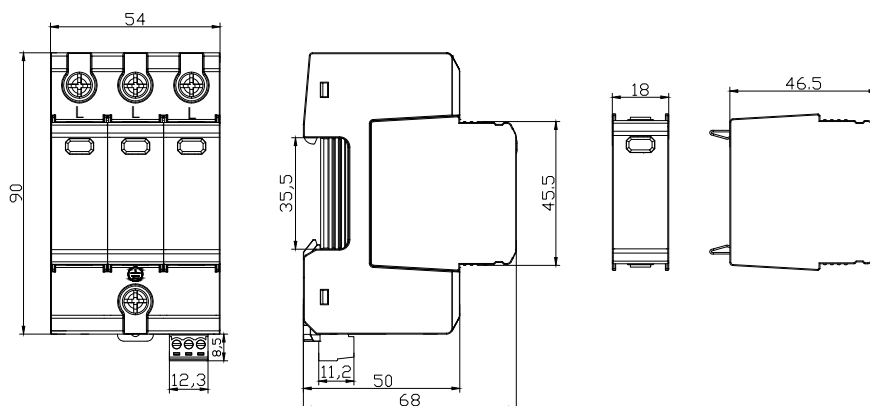

Connection Diagram

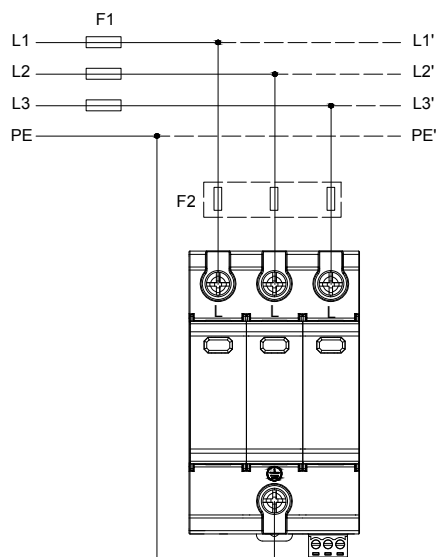

LY1-B65/4(S)

Pluggable Multi-Pole SPD



Class I • Class II • Type 1 • Type 2

Location of Use: Sub-Distribution Boards

Mode of Protection: L-PE, N-PE

Surge Ratings: $I_n = 10 \text{ kA}$ (8/20 μs)

IEC/EN/UL Category: Class I+II / Type 1+2

Protective Elements: High Energy MOV

Housing: Pluggable Design

Compliance: IEC 61643-11:2011

EN 61643-11:2012

■ Technical Data

IEC Electrical		150	275	320	385	440
Nominal AC Voltage (50/60Hz)	U_o / U_n	120 V	230 V	230 V	230 V	400 V
Maximum Continuous Operating Voltage (AC)	U_c	150 V	275V	320 V	385 V	440 V
Nominal Discharge Current (8/20 μs)	I_n	35 kA	35 kA	35 kA	35 kA	35 kA
Maximum Discharge Current (8/20 μs)	I_{max}	65 kA	65 kA	65 kA	65 kA	65 kA
Impulse Discharge Current (10/350 μs)	I_{imp}			7kA		
Voltage Protection Level	U_p	1.2 kV	1.5 kV	1.8 kV	2 kV	2.2 kV
Response Time	t_A			< 25 ns		
Back-Up Fuse (max)				125 A gL / gG		
Short-Circuit Current Rating (AC)	I_{SCCR}			35 kA / 50 kA		
TOV Withstand 5s	U_T	180V	335V	335V	335V	580V
TOV 120min	U_T	230V	440V	440V	440V	765V
	mode	Withstand	Safe Fail	Safe Fail	Safe Fail	Safe Fail
Mechanical & Environmental						
Operating Temperature Range	T_a	-40°F to +158°F [-40°C to +70°C]				
Permissible Operating Humidity	RH	5%...95%				
Atmospheric pressure and altitude		80k Pa ... 106k Pa / -500 m.....2000 m				
Terminal Screw Torque	M_{max}	39.9 lbf-in [4.5 Nm]				
Conductor Cross Section (max)		2 AWG (Solid, Stranded) / 4 AWG (Flexible) 35 mm ² (Solid, Stranded) / 25 mm ² (Flexible)				
Mounting		35 mm DIN Rail, EN 60715				
Degree of Protection		IP 20 (built-in)				
Housing Material		Thermoplastic: Extinguishing Degree UL 94 V-0				
Thermal Protection		Yes				
Operating State / Fault Indication		Green ok / Red defect				
Remote Contacts (RC)		Optional				
RC Switching Capacity		AC: 250V / 0.5 A; DC: 250V / 0.1 A;125V / 0.2 A;75V / 0.5 A				
RC Conductor Cross Section (max)		16 AWG (Solid) / 1.5 mm ² (Solid)				

LY1-B65/4(S)

Pluggable Multi-Pole SPD



Internal Configuration

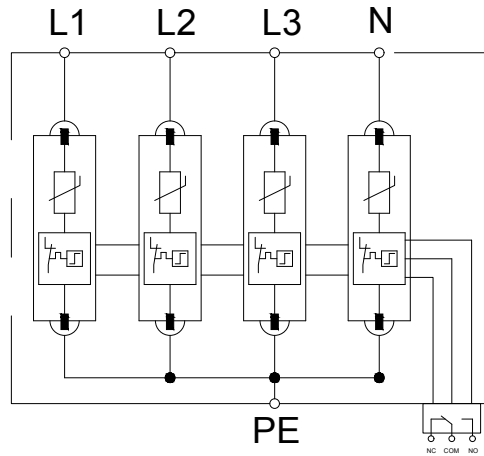

Dimensions & Packaging

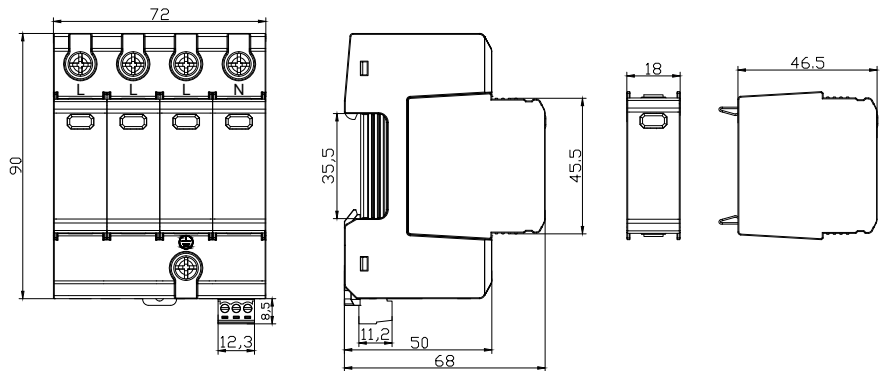

Connection Diagram

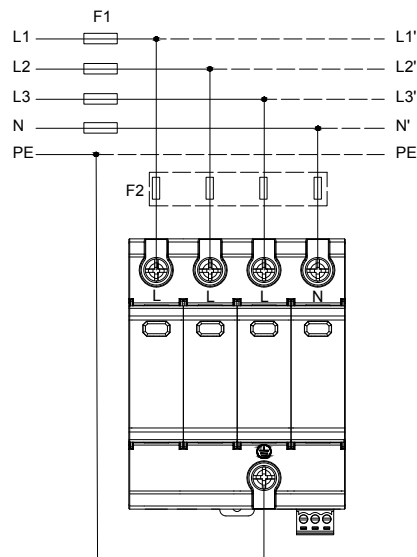

LY1-B65/1(S)+1 Pluggable Single-Pole SPD



Class I • Class II • Type 1 • Type 2

Location of Use: Sub-Distribution Boards
 Mode of Protection: L-N, N-PE
 Surge Ratings: $I_n = 10 \text{ kA}$ (8/20 μs)
 IEC/EN/UL Category: Class I+II / Type 1+2
 Protective Elements: High Energy MOV and GDT
 Housing: Pluggable Design
 Compliance: IEC 61643-11:2011
 EN 61643-11:2012

■ Technical Data

IEC Electrical		75	150	275	320	385	440
Nominal AC Voltage (50/60Hz)		60 V	120 V	230 V	230 V	230 V	400 V
Maximum Continuous Operating Voltage (AC)	(L - N) U_c	75 V	150 V	275V	320 V	385 V	440 V
	(N - PE) U_c	255V					
Nominal Discharge Current (8/20 μs)	(L - N) / (N - PE) I_n	35kV / 35kA					
Maximum Discharge Current (8/20 μs)	(L - N) / (N - PE) I_{max}	65kA / 65kA					
Impulse Discharge Current (10/350 μs)	(L - N) / (N - PE) I_{imp}	7 kA/25 kA					
Voltage Protection Level	(L - N) / (N - PE) U_p	0.8kV/1.8kV	1.2kV/1.8kV	1.5kV/1.8kV	1.8kV/1.8kV	2.0kV/1.8kV	2.2kV/1.8kV
Follow Current Interrupt Rating	(N - PE) I_f	100A _{RMS}					
Response Time	(L - N) / (N - PE) t_A	< 25 ns / < 100 ns					
Back-Up Fuse (max)		125 A gL / gG					
Short-Circuit Current Rating (AC)	(L - N) I_{SCCR}	35 kA / 50 kA					
TOV Withstand 5s	(L - N) U_T	90V	180V	335V	335V	335V	580V
TOV 120min	(L - N) U_T	115V	230V	440V	440V	440V	765V
	mode	Withstand	Withstand	Safe Fail	Safe Fail	Safe Fail	Safe Fail
TOV Withstand 200ms	(N - PE) U_T	1200V					
Mechanical & Environmental							
Operating Temperature Range	T_a	-40°F to +158°F [-40°C to +70°C]					
Permissible Operating Humidity	RH	5%...95%					
Atmospheric pressure and altitude		80k Pa ... 106k Pa / -500 m.....2000 m					
Terminal Screw Torque	M_{max}	39.9 lbf·in [4.5 Nm]					
Conductor Cross Section (max)		2 AWG (Solid, Stranded) / 4 AWG (Flexible)					
		35 mm ² (Solid, Stranded) / 25 mm ² (Flexible)					
Mounting		35 mm DIN Rail, EN 60715					
Degree of Protection		IP 20 (built-in)					
Housing Material		Thermoplastic: Extinguishing Degree UL 94 V-0					
Thermal Protection		Yes					
Operating State / Fault Indication		Green ok / Red defect					
Remote Contacts (RC)		Optional					
RC Switching Capacity		AC: 250V / 0.5 A; DC: 250V / 0.1 A; 125 V / 0.2 A; 75 V / 0.5 A					
RC Conductor Cross Section (max)		16 AWG (Solid) / 1.5 mm ² (Solid)					

LY1-B65/1(S)+1

Pluggable Single-Pole SPD



Internal Configuration

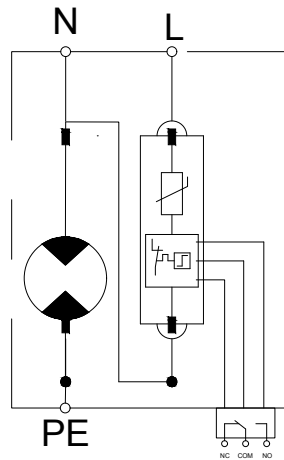

Dimensions & Packaging

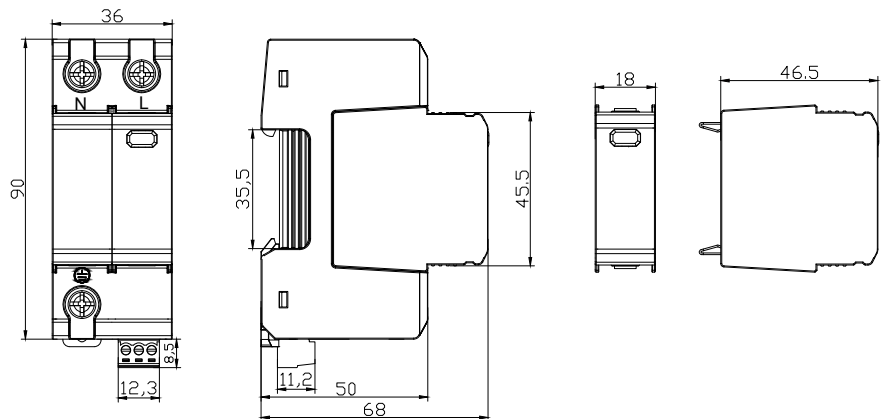

Connection Diagram

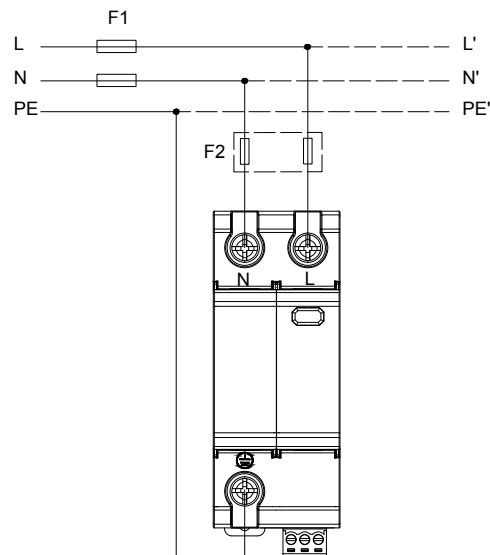

LY1-B65/3(S)+1 Pluggable Multi-Pole SPD



Class I • Class II • Type 1 • Type 2

Location of Use: Sub-Distribution Boards

Mode of Protection: L-N, N-PE

Surge Ratings: $I_n = 10 \text{ kA}$ (8/20 μs)

IEC/EN/UL Category: Class I+II / Type 1+2

Protective Elements: High Energy MOV and GDT

Housing: Pluggable Design

Compliance: IEC 61643-11:2011

EN 61643-11:2012

■ Technical Data

IEC Electrical		150	275	320	385	440
Nominal AC Voltage (50/60Hz)		120 V	230 V	230 V	230 V	400 V
Maximum Continuous Operating Voltage (AC)	(L - N) U_c	150 V	275V	320 V	385 V	440 V
	(N - PE) U_c			255V		
Nominal Discharge Current (8/20 μs)	(L - N) / (N - PE) I_n			35kV / 35kA		
Maximum Discharge Current (8/20 μs)	(L - N) / (N - PE) I_{max}			65kA / 65kA		
Impulse Discharge Current (10/350 μs)	(L - N) / (N - PE) I_{imp}			7 kA/25 kA		
Voltage Protection Level	(L - N) / (N - PE) U_p	1.2kV / 1.8kV	1.5kV / 1.8kV	1.8kV / 1.8kV	2.0kV / 1.8kV	2.2kV / 1.8kV
Follow Current Interrupt Rating	(N - PE) I_f			100A _{RMS}		
Response Time	(L - N) / (N - PE) t_A			< 25 ns / < 100 ns		
Back-Up Fuse (max)				125 A gL / gG		
Short-Circuit Current Rating (AC)	(L - N) I_{SCCR}			35 kA / 50 kA		
TOV Withstand 5s	(L - N) U_T	180V	335V	335V	335V	580V
TOV 120min	(L - N) U_T	230V	440V	440V	440V	765V
	mode	Withstand	Safe Fail	Safe Fail	Safe Fail	Safe Fail
TOV Withstand 200ms	(N - PE) U_T			1200V		
Mechanical & Environmental						
Operating Temperature Range	T_a	-40°F to +158°F [-40°C to +70°C]				
Permissible Operating Humidity	RH	5%...95%				
Atmospheric pressure and altitude		80k Pa ... 106k Pa / -500 m.....2000 m				
Terminal Screw Torque	M_{max}	39.9 lbf-in [4.5 Nm]				
Conductor Cross Section (max)		2 AWG (Solid, Stranded) / 4 AWG (Flexible)				
		35 mm ² (Solid, Stranded) / 25 mm ² (Flexible)				
Mounting		35 mm DIN Rail, EN 60715				
Degree of Protection		IP 20 (built-in)				
Housing Material		Thermoplastic: Extinguishing Degree UL 94 V-0				
Thermal Protection		Yes				
Operating State / Fault Indication		Green ok / Red defect				
Remote Contacts (RC)		Optional				
RC Switching Capacity		AC: 250V / 0.5 A; DC: 250V / 0.1 A; 125 V / 0.2 A; 75 V / 0.5 A				
RC Conductor Cross Section (max)		16 AWG (Solid) / 1.5 mm ² (Solid)				

LY1-B65/3(S)+1

Pluggable Multi-Pole SPD



Internal Configuration

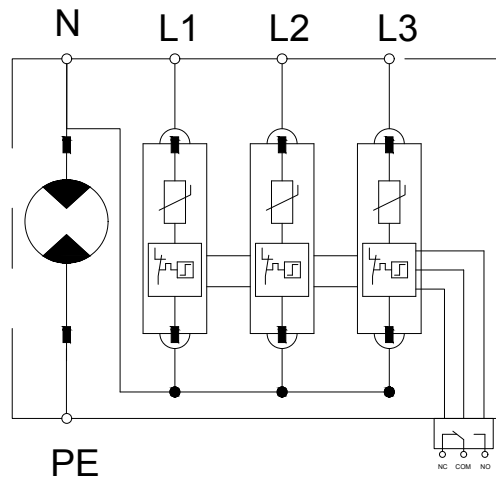

Dimensions & Packaging

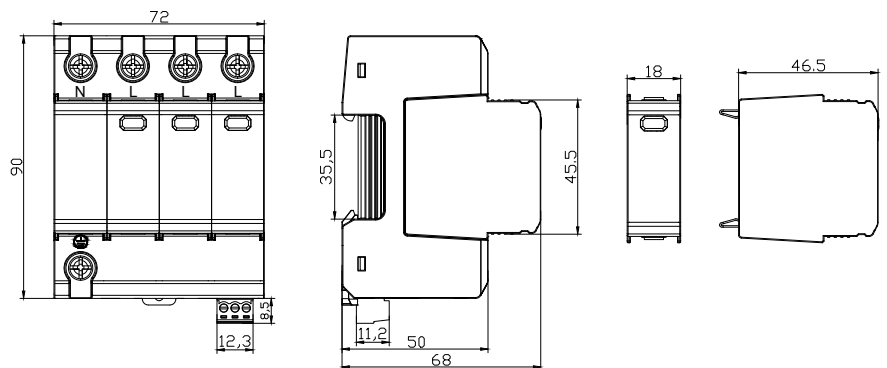

Connection Diagram

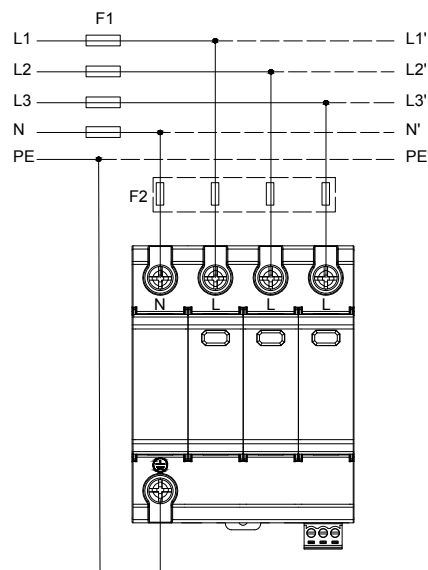

LY1-B80/1(S) Pluggable Single-Pole SPD



Class I • Class II • Type 1 • Type 2

Location of Use: Sub-Distribution Boards
 Mode of Protection: L-PE, N-PE
 Surge Ratings: $I_n = 40 \text{ kA}$ (8/20 μs)
 IEC/EN/UL Category: Class I+II / Type 1+2
 Protective Elements: High Energy MOV
 Housing: Pluggable Design
 Compliance: IEC 61643-11:2011
 EN 61643-11:2012

■ Technical Data

IEC Electrical		75	150	275	320	385	440
Nominal AC Voltage (50/60Hz)	U_o / U_n	60 V	120 V	230 V	230 V	230 V	400 V
Maximum Continuous Operating Voltage (AC)	U_c	75 V	150 V	275V	320 V	385 V	440 V
Nominal Discharge Current (8/20 μs)	I_n	40 kA	40 kA	40 kA	40 kA	40 kA	40 kA
Maximum Discharge Current (8/20 μs)	I_{max}	80 kA	80 kA	80 kA	80 kA	80 kA	80 kA
Impulse Discharge Current (10/350 μs)	I_{imp}	7kA					
Voltage Protection Level	U_p	0.8 kV	1.2 kV	2 kV	2 kV	2 kV	2.2 kV
Response Time	t_A	< 25 ns					
Back-Up Fuse (max)		125 A gL / gG					
Short-Circuit Current Rating (AC)	I_{SCCR}	35 kA / 50 kA					
TOV Withstand 5s	U_T	90V	180V	335V	335V	335V	580V
TOV 120min	U_T	115V	230V	440V	440V	440V	765V
	mode	Withstand	Withstand	Safe Fail	Safe Fail	Safe Fail	Safe Fail
Mechanical & Environmental							
Operating Temperature Range	T_a	-40°F to +158°F [-40°C to +70°C]					
Permissible Operating Humidity	RH	5%...95%					
Atmospheric pressure and altitude		80k Pa ... 106k Pa / -500 m.....2000 m					
Terminal Screw Torque	M_{max}	39.9 lbf·in [4.5 Nm]					
Conductor Cross Section (max)		2 AWG (Solid, Stranded) / 4 AWG (Flexible) 35 mm ² (Solid, Stranded) / 25 mm ² (Flexible)					
Mounting		35 mm DIN Rail, EN 60715					
Degree of Protection		IP 20 (built-in)					
Housing Material		Thermoplastic: Extinguishing Degree UL 94 V-0					
Thermal Protection		Yes					
Operating State / Fault Indication		Green ok / Red defect					
Remote Contacts (RC)		Optional					
RC Switching Capacity		AC: 250V / 0.5 A; DC: 250V / 0.1 A; 125V / 0.2 A; 75V / 0.5 A					
RC Conductor Cross Section (max)		16 AWG (Solid) / 1.5 mm ² (Solid)					

LY1-B80/1(S)

Pluggable Single-Pole SPD



Internal Configuration

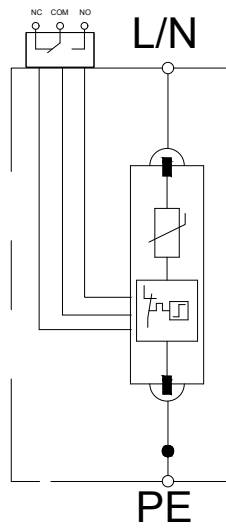

Dimensions & Packaging

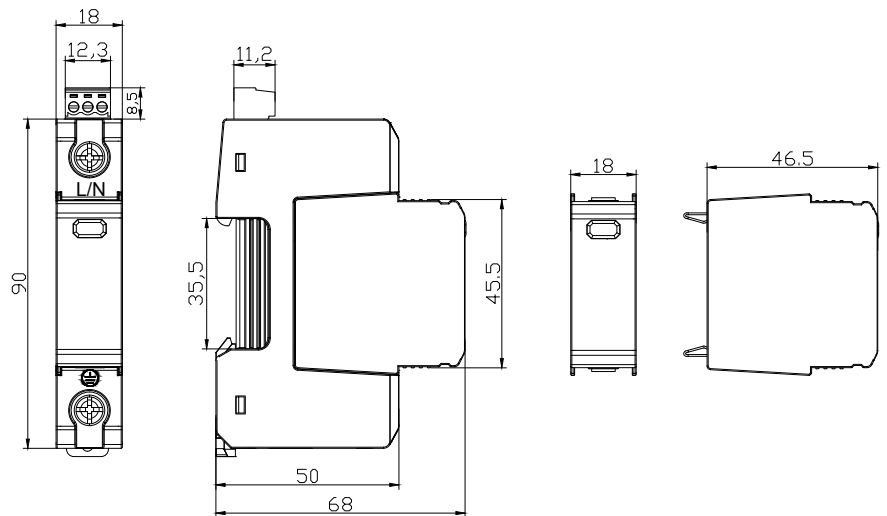

Connection Diagram

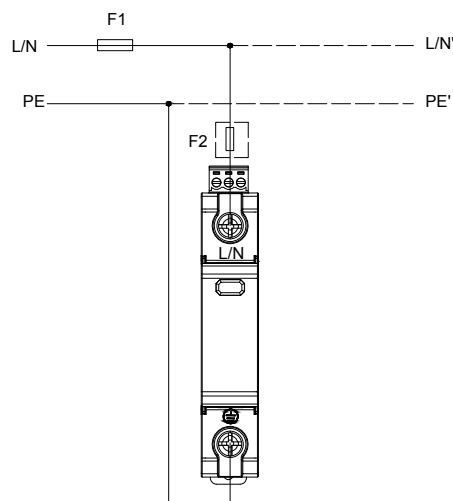

LY1-B80/2(S) Pluggable Single-Pole SPD



Class I • Class II • Type 1 • Type 2

Location of Use: Sub-Distribution Boards

Mode of Protection: L-PE, N-PE

Surge Ratings: $I_n = 40 \text{ kA}$ (8/20 μs)

IEC/EN/UL Category: Class I+II / Type 1+2

Protective Elements: High Energy MOV

Housing: Pluggable Design

Compliance: IEC 61643-11:2011

EN 61643-11:2012

■ Technical Data

IEC Electrical		75	150	275	320	385	440
Nominal AC Voltage (50/60Hz)	U_o / U_n	60 V	120 V	230 V	230 V	230 V	400 V
Maximum Continuous Operating Voltage (AC)	U_c	75 V	150 V	275V	320 V	385 V	440 V
Nominal Discharge Current (8/20 μs)	I_n	40 kA	40 kA	40 kA	40 kA	40 kA	40 kA
Maximum Discharge Current (8/20 μs)	I_{max}	80 kA	80 kA	80 kA	80 kA	80 kA	80 kA
Impulse Discharge Current (10/350 μs)	I_{imp}	7kA					
Voltage Protection Level	U_p	0.8 kV	1.2 kV	2 kV	2 kV	2 kV	2.2 kV
Response Time	t_A	< 25 ns					
Back-Up Fuse (max)		125 A gL / gG					
Short-Circuit Current Rating (AC)	I_{SCCR}	35 kA / 50 kA					
TOV Withstand 5s	U_T	90V	180V	335V	335V	335V	580V
TOV 120min	U_T	115V	230V	440V	440V	440V	765V
	mode	Withstand	Withstand	Safe Fail	Safe Fail	Safe Fail	Safe Fail
Mechanical & Environmental							
Operating Temperature Range	T_a	-40°F to +158°F [-40°C to +70°C]					
Permissible Operating Humidity	RH	5%...95%					
Atmospheric pressure and altitude		80k Pa ... 106k Pa / -500 m.....2000 m					
Terminal Screw Torque	M_{max}	39.9 lbf·in [4.5 Nm]					
Conductor Cross Section (max)		2 AWG (Solid, Stranded) / 4 AWG (Flexible) 35 mm ² (Solid, Stranded) / 25 mm ² (Flexible)					
Mounting		35 mm DIN Rail, EN 60715					
Degree of Protection		IP 20 (built-in)					
Housing Material		Thermoplastic: Extinguishing Degree UL 94 V-0					
Thermal Protection		Yes					
Operating State / Fault Indication		Green ok / Red defect					
Remote Contacts (RC)		Optional					
RC Switching Capacity		AC: 250V / 0.5 A; DC: 250V / 0.1 A; 125V / 0.2 A; 75V / 0.5 A					
RC Conductor Cross Section (max)		16 AWG (Solid) / 1.5 mm ² (Solid)					

LY1-B80/2(S)

Pluggable Single-Pole SPD



Internal Configuration

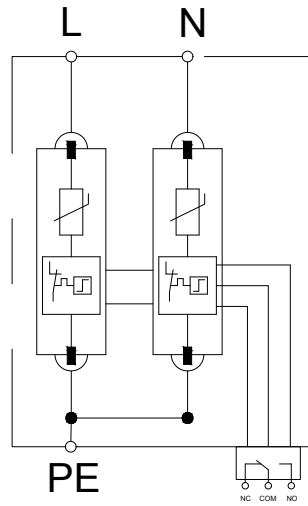

Dimensions & Packaging

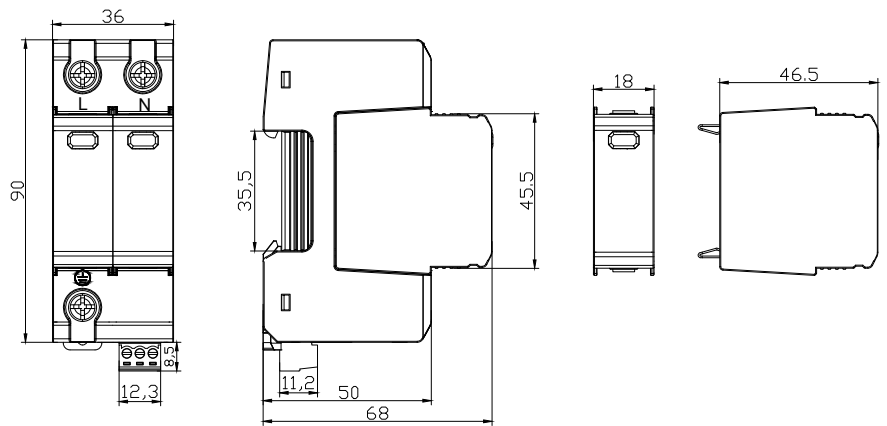

Connection Diagram

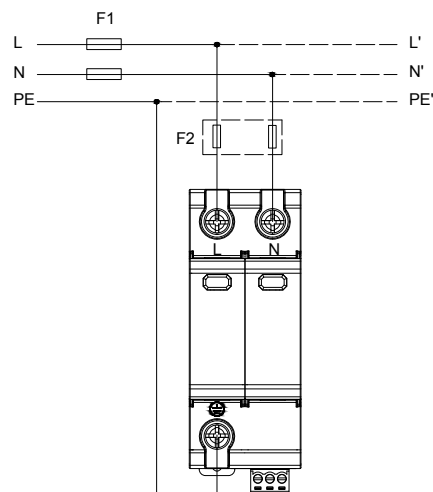

LY1-B80/3(S) Pluggable Multi-Pole SPD



Class I • Class II • Type 1 • Type 2

Location of Use: Sub-Distribution Boards

Mode of Protection: L-PE, N-PE

Surge Ratings: $I_n = 40 \text{ kA}$ (8/20 μs)

IEC/EN/UL Category: Class I+II / Type 1+2

Protective Elements: High Energy MOV

Housing: Pluggable Design

Compliance: IEC 61643-11:2011

EN 61643-11:2012

Technical Data

IEC Electrical		150	275	320	385	440
Nominal AC Voltage (50/60Hz)	U_o / U_n	120 V	230 V	230 V	230 V	400 V
Maximum Continuous Operating Voltage (AC)	U_c	150 V	275V	320 V	385 V	440 V
Nominal Discharge Current (8/20 μs)	I_n	40 kA	40 kA	40 kA	40 kA	40 kA
Maximum Discharge Current (8/20 μs)	I_{max}	80 kA	80 kA	80 kA	80 kA	80 kA
Impulse Discharge Current (10/350 μs)	I_{imp}			7kA		
Voltage Protection Level	U_p	1.2 kV	2 kV	2 kV	2 kV	2.2 kV
Response Time	t_A			< 25 ns		
Back-Up Fuse (max)				125 A gL / gG		
Short-Circuit Current Rating (AC)	I_{SCCR}			35 kA / 50 kA		
TOV Withstand 5s	U_T	180V	335V	335V	335V	580V
TOV 120min	U_T	230V	440V	440V	440V	765V
	mode	Withstand	Safe Fail	Safe Fail	Safe Fail	Safe Fail
Mechanical & Environmental						
Operating Temperature Range	T_a	-40°F to +158°F [-40°C to +70°C]				
Permissible Operating Humidity	RH	5%...95%				
Atmospheric pressure and altitude		80k Pa ... 106k Pa / -500 m.....2000 m				
Terminal Screw Torque	M_{max}	39.9 lbf-in [4.5 Nm]				
Conductor Cross Section (max)		2 AWG (Solid, Stranded) / 4 AWG (Flexible) 35 mm ² (Solid, Stranded) / 25 mm ² (Flexible)				
Mounting		35 mm DIN Rail, EN 60715				
Degree of Protection		IP 20 (built-in)				
Housing Material		Thermoplastic: Extinguishing Degree UL 94 V-0				
Thermal Protection		Yes				
Operating State / Fault Indication		Green ok / Red defect				
Remote Contacts (RC)		Optional				
RC Switching Capacity		AC: 250V / 0.5 A; DC: 250V / 0.1 A; 125V / 0.2 A; 75V / 0.5 A				
RC Conductor Cross Section (max)		16 AWG (Solid) / 1.5 mm ² (Solid)				

LY1-B80/3(S)

Pluggable Multi-Pole SPD



Internal Configuration

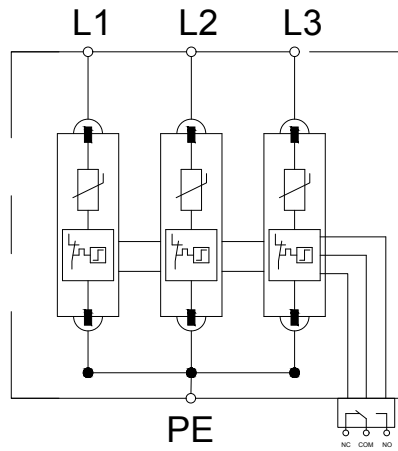

Dimensions & Packaging

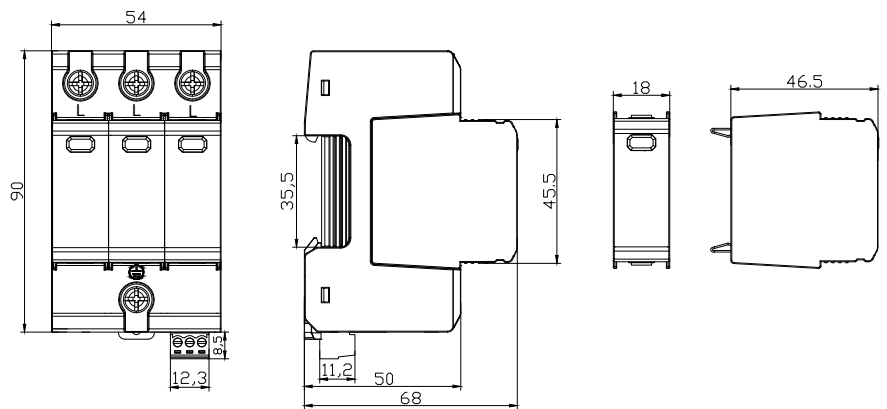

Connection Diagram

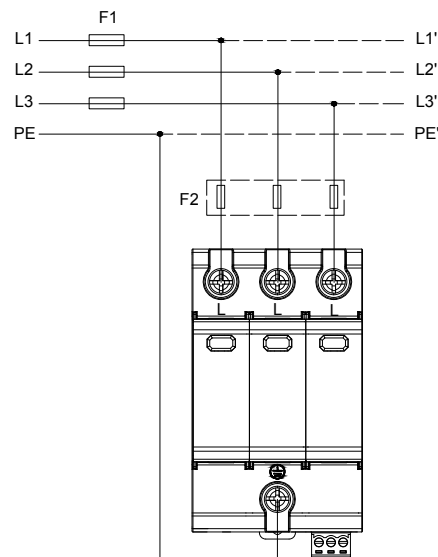

LY1-B80/4(S) Pluggable Multi-Pole SPD



Class I • Class II • Type 1 • Type 2

Location of Use: Sub-Distribution Boards

Mode of Protection: L-PE, N-PE

Surge Ratings: $I_n = 40 \text{ kA}$ (8/20 μs)

IEC/EN/UL Category: Class I+II / Type 1+2

Protective Elements: High Energy MOV

Housing: Pluggable Design

Compliance: IEC 61643-11:2011

EN 61643-11:2012

■ Technical Data

IEC Electrical		150	275	320	385	440
Nominal AC Voltage (50/60Hz)	U_o / U_n	120 V	230 V	230 V	230 V	400 V
Maximum Continuous Operating Voltage (AC)	U_c	150 V	275V	320 V	385 V	440 V
Nominal Discharge Current (8/20 μs)	I_n	40 kA	40 kA	40 kA	40 kA	40 kA
Maximum Discharge Current (8/20 μs)	I_{max}	80 kA	80 kA	80 kA	80 kA	80 kA
Impulse Discharge Current (10/350 μs)	I_{imp}			7kA		
Voltage Protection Level	U_p	1.2 kV	2 kV	2 kV	2 kV	2.2 kV
Response Time	t_A			< 25 ns		
Back-Up Fuse (max)				125 A gL / gG		
Short-Circuit Current Rating (AC)	I_{SCCR}			35 kA / 50 kA		
TOV Withstand 5s	U_T	180V	335V	335V	335V	580V
TOV 120min	U_T	230V	440V	440V	440V	765V
	mode	Withstand	Safe Fail	Safe Fail	Safe Fail	Safe Fail
Mechanical & Environmental						
Operating Temperature Range	T_a	-40°F to +158°F [-40°C to +70°C]				
Permissible Operating Humidity	RH	5%...95%				
Atmospheric pressure and altitude		80k Pa ... 106k Pa / -500 m.....2000 m				
Terminal Screw Torque	M_{max}	39.9 lbf-in [4.5 Nm]				
Conductor Cross Section (max)		2 AWG (Solid, Stranded) / 4 AWG (Flexible) 35 mm ² (Solid, Stranded) / 25 mm ² (Flexible)				
Mounting		35 mm DIN Rail, EN 60715				
Degree of Protection		IP 20 (built-in)				
Housing Material		Thermoplastic: Extinguishing Degree UL 94 V-0				
Thermal Protection		Yes				
Operating State / Fault Indication		Green ok / Red defect				
Remote Contacts (RC)		Optional				
RC Switching Capacity		AC: 250V / 0.5 A; DC: 250V / 0.1 A;125V / 0.2 A;75V / 0.5 A				
RC Conductor Cross Section (max)		16 AWG (Solid) / 1.5 mm ² (Solid)				

LY1-B80/4(S)

Pluggable Multi-Pole SPD



Internal Configuration

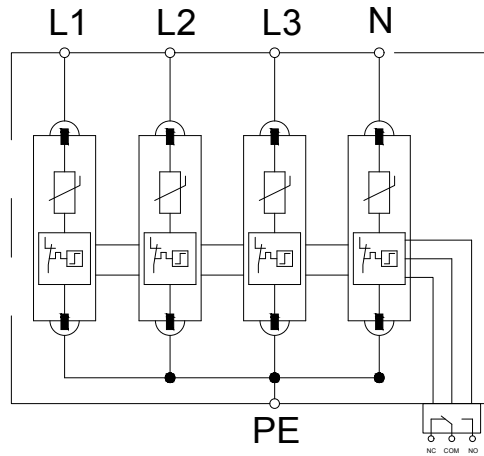

Dimensions & Packaging

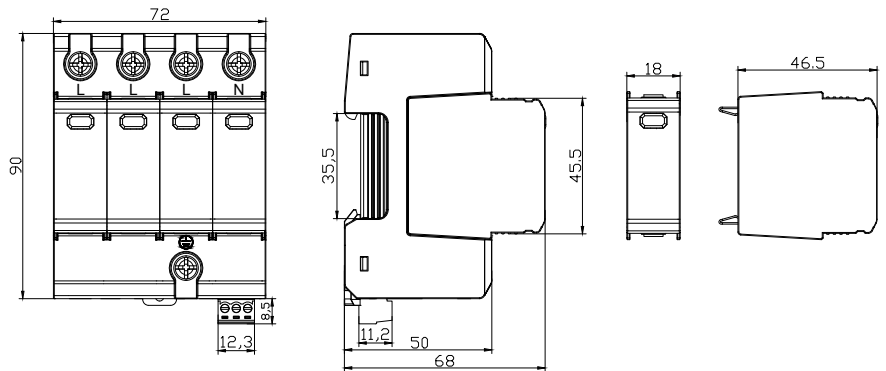

Connection Diagram

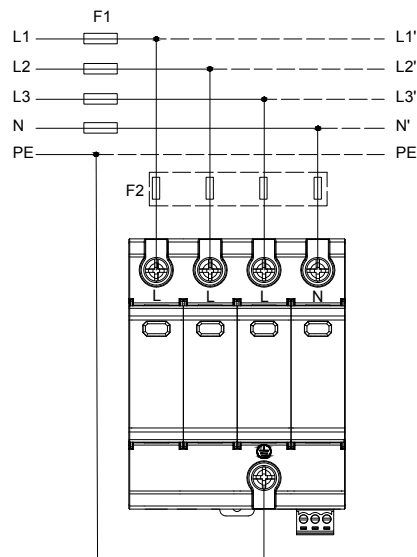

LY1-B80/1(S)+1 Pluggable Single-Pole SPD



Class I • Class II • Type 1 • Type 2

Location of Use: Sub-Distribution Boards
 Mode of Protection: L-N, N-PE
 Surge Ratings: $I_n = 40 \text{ kA}$ (8/20 μs)
 IEC/EN/UL Category: Class I+II / Type 1+2
 Protective Elements: High Energy MOV and GDT
 Housing: Pluggable Design
 Compliance: IEC 61643-11:2011
 EN 61643-11:2012

■ Technical Data

IEC Electrical		75	150	275	320	385	440
Nominal AC Voltage (50/60Hz)		60 V	120 V	230 V	230 V	230 V	400 V
Maximum Continuous Operating Voltage (AC)	(L - N) U_c	75 V	150 V	275V	320 V	385 V	440 V
	(N - PE) U_c	255V					
Nominal Discharge Current (8/20 μs)	(L - N) / (N - PE) I_n	40kV / 40kA					
Maximum Discharge Current (8/20 μs)	(L - N) / (N - PE) I_{max}	80kA / 80kA					
Impulse Discharge Current (10/350 μs)	L - N) / (N - PE) I_{imp}	7 kA/25 kA					
Voltage Protection Level	(L - N) / (N - PE) U_p	0.8kV/1.8kV	1.2kV/1.8kV	2.0kV/1.8kV	2.0kV/1.8kV	2.0kV/1.8kV	2.2kV/1.8kV
Follow Current Interrupt Rating	(N - PE) I_f	100A _{RMS}					
Response Time	(L - N) / (N - PE) t_A	< 25 ns / < 100 ns					
Back-Up Fuse (max)		125 A gL / gG					
Short-Circuit Current Rating (AC)	(L - N) I_{SCCR}	35 kA / 50 kA					
TOV Withstand 5s	(L - N) U_T	90V	180V	335V	335V	335V	580V
TOV 120min	(L - N) U_T	115V	230V	440V	440V	440V	765V
	mode	Withstand	Withstand	Safe Fail	Safe Fail	Safe Fail	Safe Fail
TOV Withstand 200ms	(N - PE) U_T	1200V					
Mechanical & Environmental							
Operating Temperature Range	T_a	-40°F to +158°F [-40°C to +70°C]					
Permissible Operating Humidity	RH	5%...95%					
Atmospheric pressure and altitude		80k Pa ... 106k Pa / -500 m.....2000 m					
Terminal Screw Torque	M_{max}	39.9 lbf·in [4.5 Nm]					
Conductor Cross Section (max)		2 AWG (Solid, Stranded) / 4 AWG (Flexible)					
		35 mm ² (Solid, Stranded) / 25 mm ² (Flexible)					
Mounting		35 mm DIN Rail, EN 60715					
Degree of Protection		IP 20 (built-in)					
Housing Material		Thermoplastic: Extinguishing Degree UL 94 V-0					
Thermal Protection		Yes					
Operating State / Fault Indication		Green ok / Red defect					
Remote Contacts (RC)		Optional					
RC Switching Capacity		AC: 250V / 0.5 A; DC: 250V / 0.1 A; 125 V / 0.2 A; 75 V / 0.5 A					
RC Conductor Cross Section (max)		16 AWG (Solid) / 1.5 mm ² (Solid)					

LY1-B80/1(S)+1

Pluggable Single-Pole SPD



Internal Configuration

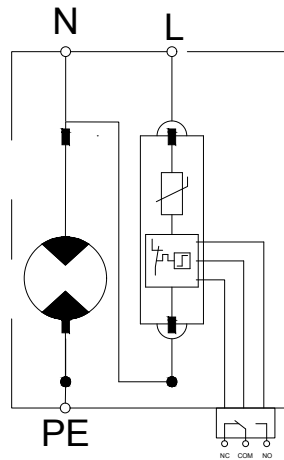

Dimensions & Packaging

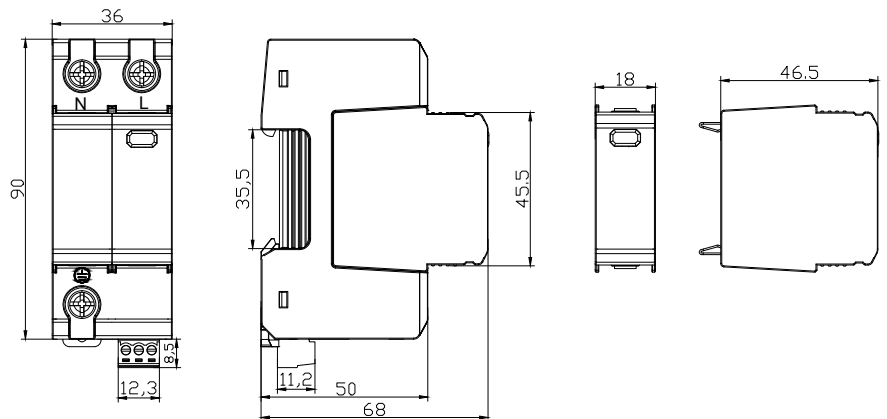

Connection Diagram

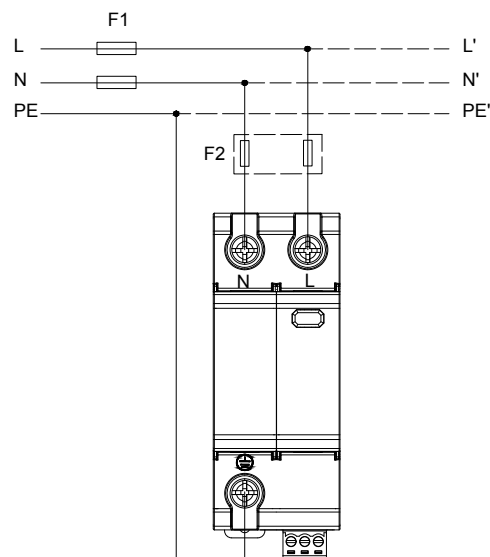

LY1-B80/3(S)+1 Pluggable Multi-Pole SPD



Class I • Class II • Type 1 • Type 2

Location of Use: Sub-Distribution Boards

Mode of Protection: L-N, N-PE

Surge Ratings: $I_n = 40 \text{ kA}$ (8/20 μs)

IEC/EN/UL Category: Class I+II / Type 1+2

Protective Elements: High Energy MOV and GDT

Housing: Pluggable Design

Compliance: IEC 61643-11:2011

EN 61643-11:2012

■ Technical Data

IEC Electrical		150	275	320	385	440
Nominal AC Voltage (50/60Hz)		120 V	230 V	230 V	230 V	400 V
Maximum Continuous Operating Voltage (AC)	(L - N) U_c	150 V	275V	320 V	385 V	440 V
	(N - PE) U_c			255V		
Nominal Discharge Current (8/20 μs)	(L - N) / (N - PE) I_n			40kV / 40kA		
Maximum Discharge Current (8/20 μs)	(L - N) / (N - PE) I_{max}			80kA / 80kA		
Impulse Discharge Current (10/350 μs)	L - N) / (N - PE) I_{imp}			7 kA/25 kA		
Voltage Protection Level	(L - N) / (N - PE) U_p	1.2kV / 1.8kV	2.0kV / 1.8kV	2.0kV / 1.8kV	2.0kV / 1.8kV	2.2kV / 1.8kV
Follow Current Interrupt Rating	(N - PE) I_f			100A _{RMS}		
Response Time	(L - N) / (N - PE) t_A			< 25 ns / < 100 ns		
Back-Up Fuse (max)				125 A gL / gG		
Short-Circuit Current Rating (AC)	(L - N) I_{SCCR}			35 kA / 50 kA		
TOV Withstand 5s	(L - N) U_T	180V	335V	335V	335V	580V
TOV 120min	(L - N) U_T	230V	440V	440V	440V	765V
	mode	Withstand	Safe Fail	Safe Fail	Safe Fail	Safe Fail
TOV Withstand 200ms	(N - PE) U_T			1200V		
Mechanical & Environmental						
Operating Temperature Range	T_a	-40°F to +158°F [-40°C to +70°C]				
Permissible Operating Humidity	RH	5%...95%				
Atmospheric pressure and altitude		80k Pa ... 106k Pa / -500 m.....2000 m				
Terminal Screw Torque	M_{max}	39.9 lbf-in [4.5 Nm]				
Conductor Cross Section (max)		2 AWG (Solid, Stranded) / 4 AWG (Flexible)				
		35 mm ² (Solid, Stranded) / 25 mm ² (Flexible)				
Mounting		35 mm DIN Rail, EN 60715				
Degree of Protection		IP 20 (built-in)				
Housing Material		Thermoplastic: Extinguishing Degree UL 94 V-0				
Thermal Protection		Yes				
Operating State / Fault Indication		Green ok / Red defect				
Remote Contacts (RC)		Optional				
RC Switching Capacity		AC: 250V / 0.5 A; DC: 250V / 0.1 A; 125 V / 0.2 A; 75 V / 0.5 A				
RC Conductor Cross Section (max)		16 AWG (Solid) / 1.5 mm ² (Solid)				

LY1-B80/3(S)+1

Pluggable Multi-Pole SPD



Internal Configuration

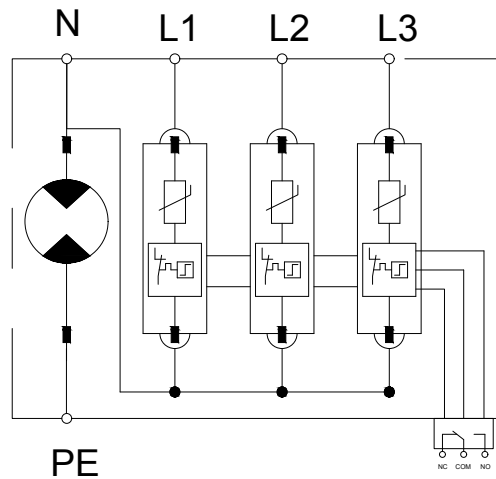

Dimensions & Packaging

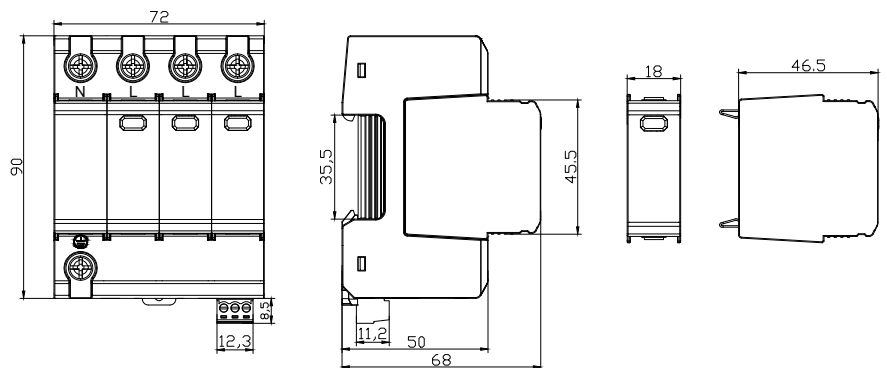

Connection Diagram

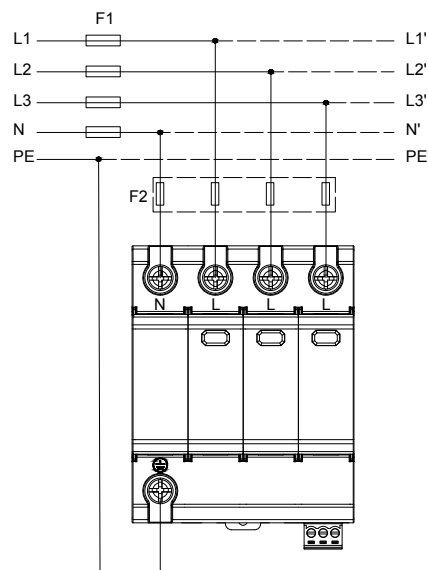

LY1-12.5/1(S) Pluggable Single-Pole SPD



Class I • Class II • Type 1 • Type 2

Location of Use: Main Distribution Boards

Mode of Protection: L-PE, N-PE

Surge Ratings: I_{imp} = up to 12.5 kA (10/350 μ s)

I_n = up to 20 kA (8 /20 μ s)

IEC/EN/UL Category: Class I+II / Type 1+2

Protective Elements: High Energy MOV

Housing: Pluggable Design

Compliance: IEC 61643-11:2011

EN 61643-11:2012

UL 1449 4th Edition

■ Technical Data

IEC Electrical		75	150	275	320	385	440
Nominal AC Voltage (50/60Hz)	U_o / U_n	60V	120 V	230 V	230 V	230 V	400 V
Maximum Continuous Operating Voltage (AC)	U_c	75V	150 V	275 V	320 V	385 V	440 V
Nominal Discharge Current (8/20 μ s)	I_n	20 kA	20 kA	20 kA	20 kA	10 kA	10 kA
Maximum Discharge Current (8/20 μ s)	I_{max}	50 kA	50 kA	50 kA	50 kA	50 kA	50 kA
Impulse Discharge Current (10/350 μ s)	I_{imp}	12.5 kA	12.5 kA	12.5 kA	12.5 kA	10 kA	10 kA
Specific Energy	W/R	39 kJ/ Ω	39 kJ/ Ω	39 kJ/ Ω	39 kJ/ Ω	25 kJ/ Ω	25 kJ/ Ω
Charge	Q	6.25 As	6.25 As	6.25 As	6.25 As	5 As	5 As
Voltage Protection Level	U_p	0.7 kV	1 kV	1.5 kV	1.6 kV	1.8 kV	2 kV
Response Time	t_A	< 25 ns					
Back-Up Fuse (max)		315 A / 250 A gG					
Short-Circuit Current Rating (AC)	I_{SCCR}	25 kA / 50 kA					
TOV Withstand 5s	U_T	114 V	180V	335V	335V	335V	580V
TOV 120min	U_T	114 V	230V	440V	440V	440V	765V
	mode	Withstand	Safe Fail	Safe Fail	Safe Fail	Safe Fail	Safe Fail
UL Electrical							
Maximum Continuous Operating Voltage (AC)	MCOV	75 V	150 V	275 V	320 V	385 V	440 V
Voltage Protection Rating	VPR	300 V	600 V	900 V	1200 V	1350 V	1500 V
Nominal Discharge Current (8/20 μ s)	I_n	20 kA	20 kA	20 kA	20 kA	20 kA	20 kA
Short-Circuit Current Rating (AC)	SCCR	100 kA	200 kA	150 kA	150 kA	150 kA	200 kA
Mechanical & Environmental							
Operating Temperature Range	T_a	-40°F to +158°F [-40°C to +70°C]					
Permissible Operating Humidity	RH	5%...95%					
Atmospheric pressure and altitude		80k Pa ... 106k Pa / -500 m.....2000 m					
Terminal Screw Torque	M_{max}	39.9 lbf-in [4.5 Nm]					
Conductor Cross Section (max)		2 AWG (Solid, Stranded) / 4 AWG (Flexible) 35 mm ² (Solid, Stranded) / 25 mm ² (Flexible)					
Mounting		35 mm DIN Rail, EN 60715					
Degree of Protection		IP 20 (built-in)					
Housing Material		Thermoplastic: Extinguishing Degree UL 94 V-0					
Thermal Protection		Yes					
Operating State / Fault Indication		Green ok / Red defect					
Remote Contacts (RC)		Optional					
RC Switching Capacity		AC: 250V / 0.5 A; DC: 250V / 0.1 A; 125 V / 0.2 A; 75 V / 0.5 A					
RC Conductor Cross Section (max)		16 AWG (Solid) / 1.5 mm ² (Solid)					

LY1-12.5/1(S)

Pluggable Single-Pole SPD



Internal Configuration

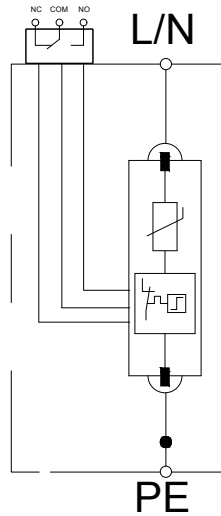

Dimensions & Packaging

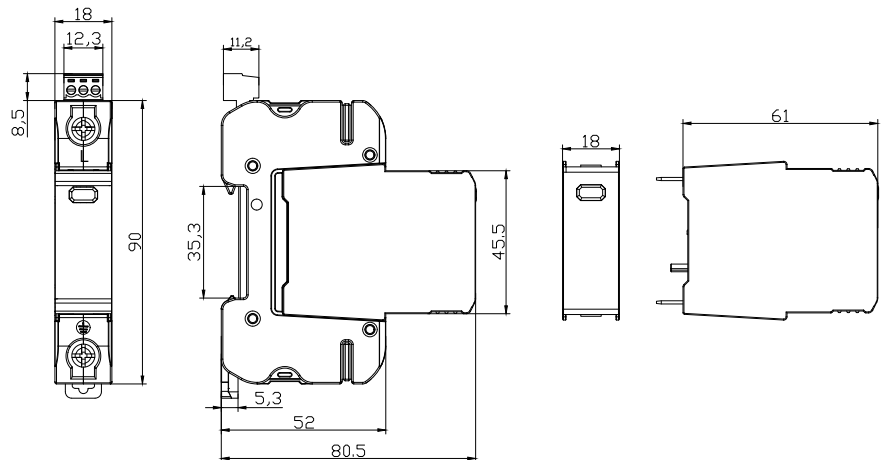

Connection Diagram

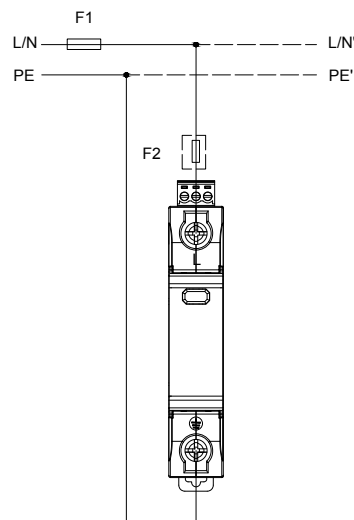

LY1-12.5/2(S) Pluggable Single-Pole SPD



Class I • Class II • Type 1 • Type 2

Location of Use: Main Distribution Boards

Mode of Protection: L-PE, N-PE

Surge Ratings: I_{imp} = up to 12.5 kA (10/350 μ s)

I_n = up to 20 kA (8 /20 μ s)

IEC/EN/UL Category: Class I+II / Type 1+2

Protective Elements: High Energy MOV

Housing: Pluggable Design

Compliance: IEC 61643-11:2011

EN 61643-11:2012

UL 1449 4th Edition

■ Technical Data

IEC Electrical		75	150	275	320	385	440
Nominal AC Voltage (50/60Hz)	U_o / U_n	60V	120 V	230 V	230 V	230 V	400 V
Maximum Continuous Operating Voltage (AC)	U_c	75V	150 V	275 V	320 V	385 V	440 V
Nominal Discharge Current (8/20 μ s)	I_n	20 kA	20 kA	20 kA	20 kA	10 kA	10 kA
Maximum Discharge Current (8/20 μ s)	I_{max}	50 kA	50 kA	50 kA	50 kA	50 kA	50 kA
Impulse Discharge Current (10/350 μ s)	I_{imp}	12.5 kA	12.5 kA	12.5 kA	12.5 kA	10 kA	10 kA
Specific Energy	W/R	39 kJ/ Ω	39 kJ/ Ω	39 kJ/ Ω	39 kJ/ Ω	25 kJ/ Ω	25 kJ/ Ω
Charge	Q	6.25 As	6.25 As	6.25 As	6.25 As	5 As	5 As
Voltage Protection Level	U_p	0.7 kV	1 kV	1.5 kV	1.6 kV	1.8 kV	2 kV
Response Time	t_a	< 25 ns					
Back-Up Fuse (max)		315 A / 250 A gG					
Short-Circuit Current Rating (AC)	I_{SCCR}	25 kA / 50 kA					
TOV Withstand 5s	U_T	114 V	180V	335V	335V	335V	580V
TOV 120min	U_T	114 V	230V	440V	440V	440V	765V
	mode	Withstand	Safe Fail	Safe Fail	Safe Fail	Safe Fail	Safe Fail
UL Electrical							
Maximum Continuous Operating Voltage (AC)	MCOV	75 V	150 V	275 V	320 V	385 V	440 V
Voltage Protection Rating	VPR	300 V	600 V	900 V	1200 V	1350 V	1500 V
Nominal Discharge Current (8/20 μ s)	I_n	20 kA	20 kA	20 kA	20 kA	20 kA	20 kA
Short-Circuit Current Rating (AC)	SCCR	100 kA	200 kA	150 kA	150 kA	150 kA	200 kA
Mechanical & Environmental							
Operating Temperature Range	T_a	-40°F to +158°F [-40°C to +70°C]					
Permissible Operating Humidity	RH	5%...95%					
Atmospheric pressure and altitude		80k Pa ... 106k Pa / -500 m.....2000 m					
Terminal Screw Torque	M_{max}	39.9 lbf-in [4.5 Nm]					
Conductor Cross Section (max)		2 AWG (Solid, Stranded) / 4 AWG (Flexible) 35 mm ² (Solid, Stranded) / 25 mm ² (Flexible)					
Mounting		35 mm DIN Rail, EN 60715					
Degree of Protection		IP 20 (built-in)					
Housing Material		Thermoplastic: Extinguishing Degree UL 94 V-0					
Thermal Protection		Yes					
Operating State / Fault Indication		Green ok / Red defect					
Remote Contacts (RC)		Optional					
RC Switching Capacity		AC: 250V / 0.5 A; DC: 250V / 0.1 A; 125 V / 0.2 A; 75 V / 0.5 A					
RC Conductor Cross Section (max)		16 AWG (Solid) / 1.5 mm ² (Solid)					

LY1-12.5/2(S)

Pluggable Single-Pole SPD



Internal Configuration

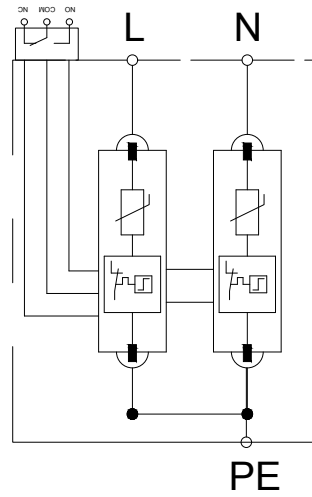

Dimensions & Packaging

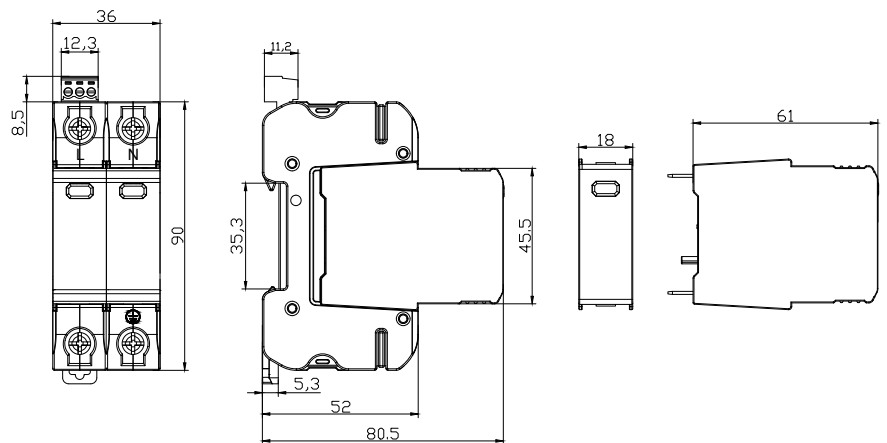

Connection Diagram

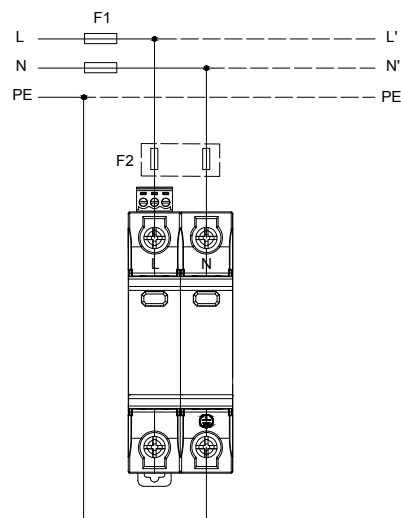

LY1-12.5/3(S) Pluggable Multi-Pole SPD



Class I • Class II • Type 1 • Type 2

Location of Use: Main Distribution Boards

Mode of Protection: L-PE, N-PE

Surge Ratings: I_{imp} = up to 12.5 kA (10/350 μ s)

I_n = up to 20 kA (8/20 μ s)

IEC/EN/UL Category: Class I+II / Type 1+2

Protective Elements: High Energy MOV

Housing: Pluggable Design

Compliance: IEC 61643-11:2011

EN 61643-11:2012

UL 1449 4th Edition

■ Technical Data

IEC Electrical		150	275	320	385	440
Nominal AC Voltage (50/60Hz)	U_o / U_n	120 V	230 V	230 V	230 V	400 V
Maximum Continuous Operating Voltage (AC)	U_c	150 V	275 V	320 V	385 V	440 V
Nominal Discharge Current (8/20 μ s)	I_n	20 kA	20 kA	20 kA	10 kA	10 kA
Maximum Discharge Current (8/20 μ s)	I_{max}	50 kA	50 kA	50 kA	50 kA	50 kA
Impulse Discharge Current (10/350 μ s)	I_{imp}	12.5 kA	12.5 kA	12.5 kA	10 kA	10 kA
Specific Energy	W/R	39 kJ/ Ω	39 kJ/ Ω	39 kJ/ Ω	25 kJ/ Ω	25 kJ/ Ω
Charge	Q	6.25 As	6.25 As	6.25 As	5 As	5 As
Voltage Protection Level	U_p	1 kV	1.5 kV	1.6 kV	1.8 kV	2 kV
Response Time	t_A	< 25 ns				
Back-Up Fuse (max)		315 A / 250 A gG				
Short-Circuit Current Rating (AC)	I_{SCCR}	25 kA / 50 kA				
TOV Withstand 5s	U_T	180V	335V	335V	335V	580V
TOV 120min	U_T	230V	440V	440V	440V	765V
	mode	Safe Fail	Safe Fail	Safe Fail	Safe Fail	Safe Fail
UL Electrical						
Maximum Continuous Operating Voltage (AC)	MCOV	150 V	275 V	320 V	385 V	440 V
Voltage Protection Rating	VPR	600 V	900 V	1200 V	1350 V	1500 V
Nominal Discharge Current (8/20 μ s)	I_n	20 kA	20 kA	20 kA	20 kA	20 kA
Short-Circuit Current Rating (AC)	SCCR	200 kA	150 kA	150 kA	150 kA	200 kA
Mechanical & Environmental						
Operating Temperature Range	T_a	-40°F to +158°F [-40°C to +70°C]				
Permissible Operating Humidity	RH	5%...95%				
Atmospheric pressure and altitude		80k Pa ... 106k Pa / -500 m.....2000 m				
Terminal Screw Torque	M_{max}	39.9 lbf-in [4.5 Nm]				
Conductor Cross Section (max)		2 AWG (Solid, Stranded) / 4 AWG (Flexible) 35 mm ² (Solid, Stranded) / 25 mm ² (Flexible)				
Mounting		35 mm DIN Rail, EN 60715				
Degree of Protection		IP 20 (built-in)				
Housing Material		Thermoplastic: Extinguishing Degree UL 94 V-0				
Thermal Protection		Yes				
Operating State / Fault Indication		Green ok / Red defect				
Remote Contacts (RC)		Optional				
RC Switching Capacity		AC: 250V / 0.5 A; DC: 250V / 0.1 A; 125 V / 0.2 A; 75 V / 0.5 A				
RC Conductor Cross Section (max)		16 AWG (Solid) / 1.5 mm ² (Solid)				

LY1-12.5/3(S)

Pluggable Multi-Pole SPD



Internal Configuration

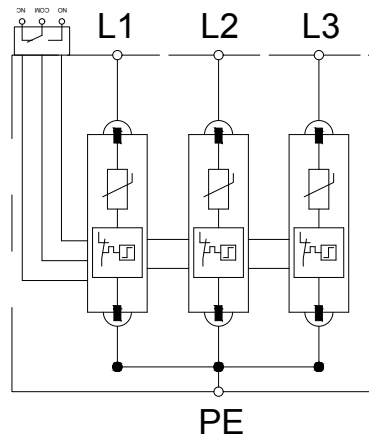

Dimensions & Packaging

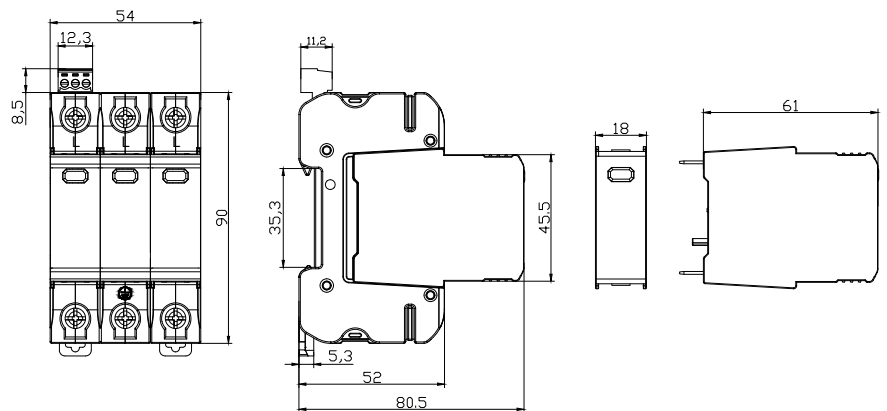

Connection Diagram

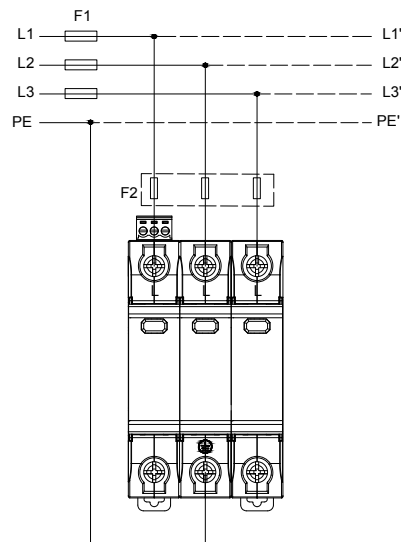

LY1-12.5/4(S) Pluggable Multi-Pole SPD



Class I • Class II • Type 1 • Type 2

Location of Use: Main Distribution Boards

Mode of Protection: L-PE, N-PE

Surge Ratings: I_{imp} = up to 12.5 kA (10/350 μ s)

I_n = up to 20 kA (8/20 μ s)

IEC/EN/UL Category: Class I+II / Type 1+2

Protective Elements: High Energy MOV

Housing: Pluggable Design

Compliance: IEC 61643-11:2011

EN 61643-11:2012

UL 1449 4th Edition

■ Technical Data

IEC Electrical		150	275	320	385	440
Nominal AC Voltage (50/60Hz)	U_o / U_n	120 V	230 V	230 V	230 V	400 V
Maximum Continuous Operating Voltage (AC)	U_c	150 V	275 V	320 V	385 V	440 V
Nominal Discharge Current (8/20 μ s)	I_n	20 kA	20 kA	20 kA	10 kA	10 kA
Maximum Discharge Current (8/20 μ s)	I_{max}	50 kA	50 kA	50 kA	50 kA	50 kA
Impulse Discharge Current (10/350 μ s)	I_{imp}	12.5 kA	12.5 kA	12.5 kA	10 kA	10 kA
Specific Energy	W/R	39 kJ/ Ω	39 kJ/ Ω	39 kJ/ Ω	25 kJ/ Ω	25 kJ/ Ω
Charge	Q	6.25 As	6.25 As	6.25 As	5 As	5 As
Voltage Protection Level	U_p	1 kV	1.5 kV	1.6 kV	1.8 kV	2 kV
Response Time	t_A	< 25 ns				
Back-Up Fuse (max)		315 A / 250 A gG				
Short-Circuit Current Rating (AC)	I_{SCCR}	25 kA / 50 kA				
TOV Withstand 5s	U_T	180V	335V	335V	335V	580V
TOV 120min	U_T	230V	440V	440V	440V	765V
	mode	Safe Fail	Safe Fail	Safe Fail	Safe Fail	Safe Fail
UL Electrical						
Maximum Continuous Operating Voltage (AC)	MCOV	150 V	275 V	320 V	385 V	440 V
Voltage Protection Rating	VPR	600 V	900 V	1200 V	1350 V	1500 V
Nominal Discharge Current (8/20 μ s)	I_n	20 kA	20 kA	20 kA	20 kA	20 kA
Short-Circuit Current Rating (AC)	SCCR	200 kA	150 kA	150 kA	150 kA	200 kA
Mechanical & Environmental						
Operating Temperature Range	T_a	-40°F to +158°F [-40°C to +70°C]				
Permissible Operating Humidity	RH	5%...95%				
Atmospheric pressure and altitude		80k Pa ... 106k Pa / -500 m.....2000 m				
Terminal Screw Torque	M_{max}	39.9 lbf-in [4.5 Nm]				
Conductor Cross Section (max)		2 AWG (Solid, Stranded) / 4 AWG (Flexible) 35 mm ² (Solid, Stranded) / 25 mm ² (Flexible)				
Mounting		35 mm DIN Rail, EN 60715				
Degree of Protection		IP 20 (built-in)				
Housing Material		Thermoplastic: Extinguishing Degree UL 94 V-0				
Thermal Protection		Yes				
Operating State / Fault Indication		Green ok / Red defect				
Remote Contacts (RC)		Optional				
RC Switching Capacity		AC: 250V / 0.5 A; DC: 250V / 0.1 A; 125 V / 0.2 A; 75 V / 0.5 A				
RC Conductor Cross Section (max)		16 AWG (Solid) / 1.5 mm ² (Solid)				

LY1-12.5/4(S)

Pluggable Multi-Pole SPD



Internal Configuration

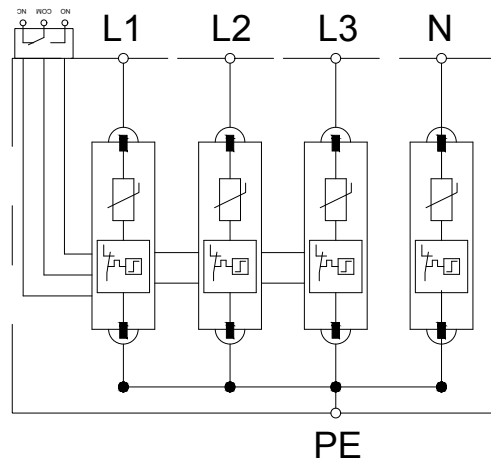

Dimensions & Packaging

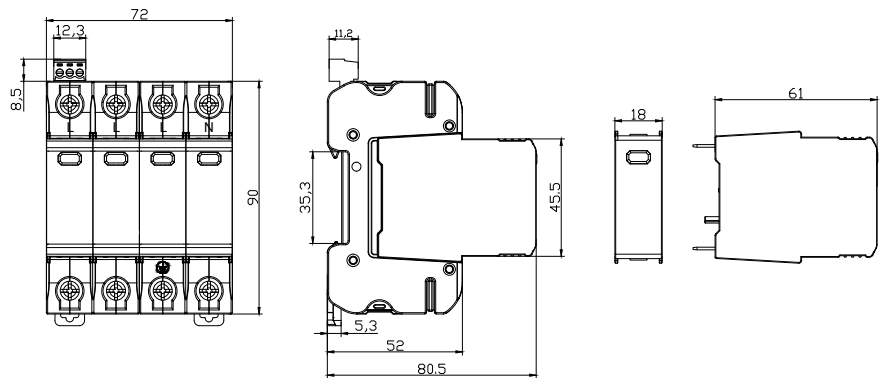

Connection Diagram

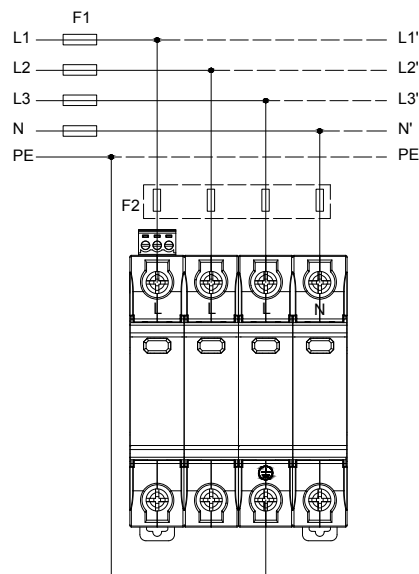

LY1-12.5/1(S)+1 Pluggable Single-Pole SPD



Class I • Class II • Type 1 • Type 2

Location of Use: Main Distribution Boards

Mode of Protection: L-N, N-PE

Surge Ratings: $I_{imp} = 12.5 \text{ kA} (10/350 \mu\text{s})$

$I_n = 20 \text{ kA} (8/20 \mu\text{s})$

IEC/EN/UL Category: Class I+II / Type 1+2

Protective Elements: High Energy MOV and GDT

Housing: Pluggable Design

Compliance: IEC 61643-11:2011

EN 61643-11:2012

UL 1449 4th Edition

■ Technical Data

IEC Electrical			75	150	275	320
Nominal AC Voltage (50/60Hz)		U_o / U_n	60V	120 V	230 V	230 V
Maximum Continuous Operating Voltage (AC)	(L-N)	U_c	75V	150 V	275 V	320 V
	(N-PE)	U_c	255 V	255 V	255 V	255 V
Nominal Discharge Current (8/20 μs)	(L-N) / (N-PE)	I_n		20 kA / 25 kA		
Maximum Discharge Current (8/20 μs)	(L-N) / (N-PE)	I_{max}		50 kA / 50 kA		
Impulse Discharge Current (10/350 μs)	(L-N) / (N-PE)	I_{imp}		12.5 kA / 25 kA		
Specific Energy	(L-N) / (N-PE)	W/R		39 kJ/ Ω / 156 kJ/ Ω		
Charge	(L-N) / (N-PE)	Q		6.25 As / 12.5 As		
Voltage Protection Level	(L-N) / (N-PE)	U_p	0.7 kV / 1.5 kV	1 kV / 1.5 kV	1.5 kV / 1.5 kV	1.6 kV / 1.5 kV
	(N-PE)	I_{R}		100 ARMS		
Response Time	(L-N) / (N-PE)	t_A		< 25 ns / < 100 ns		
Back-Up Fuse (max)				315 A / 250 A gG		
Short-Circuit Current Rating (AC)	(L-N)	I_{SCCR}		25 kA / 50 kA		
TOV Withstand 5s	(L-N)	U_T	114 V	180 V	335 V	335 V
TOV 120min	(L-N)	U_T	114 V	230 V	440 V	440 V
TOV Withstand 200ms	(N-PE)	mode	Withstand	Safe Fail	Safe Fail	Safe Fail
		U_T		1200 V		
UL Electrical						
Maximum Continuous Operating Voltage (AC)	(L-N) / (N-PE)	MCOV	75 V / 255 V	150 V / 255 V	275 V / 255 V	320 V / 255 V
Voltage Protection Rating	(L-N) / (N-PE)	VPR	330 V / 1200 V	600 V / 1200 V	900 V / 1200 V	1200 V / 1200 V
Nominal Discharge Current (8/20 μs)	(L-N) / (N-PE)	I_n	20 kA / 20 kA	20 kA / 20 kA	20 kA / 20 kA	20 kA / 20 kA
Short-Circuit Current Rating (AC)	(L-N)	SCCR	100 kA	200 kA	150 kA	150 kA
Mechanical & Environmental						
Operating Temperature Range		T_a		-40°F to +158°F [-40°C to +70°C]		
Permissible Operating Humidity		RH		5%...95%		
Atmospheric pressure and altitude				80k Pa ... 106k Pa / -500 m....2000 m		
Terminal Screw Torque		M_{max}		39.9 lbf-in [4.5 Nm]		
Conductor Cross Section (max)				2 AWG (Solid, Stranded) / 4 AWG (Flexible)		
				35 mm ² (Solid, Stranded) / 25 mm ² (Flexible)		
Mounting				35 mm DIN Rail, EN 60715		
Degree of Protection				IP 20 (built-in)		
Housing Material				Thermoplastic: Extinguishing Degree UL 94 V-0		
Thermal Protection				Yes		
Operating State / Fault Indication				Green ok / Red defect		
Remote Contacts (RC)				Optional		
RC Switching Capacity				AC: 250V / 0.5 A; DC: 250V / 0.1 A; 125 V / 0.2 A; 75 V / 0.5 A		
RC Conductor Cross Section (max)				16 AWG (Solid) / 1.5 mm ² (Solid)		

LY1-12.5/1(S)+1

Pluggable Single-Pole SPD



Internal Configuration

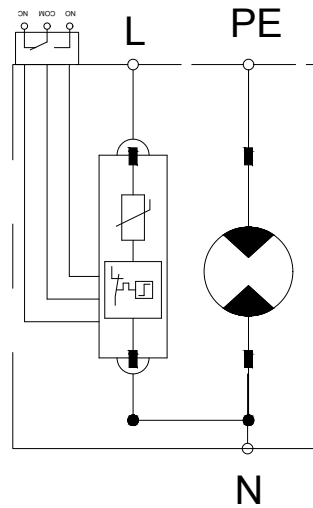

Dimensions & Packaging

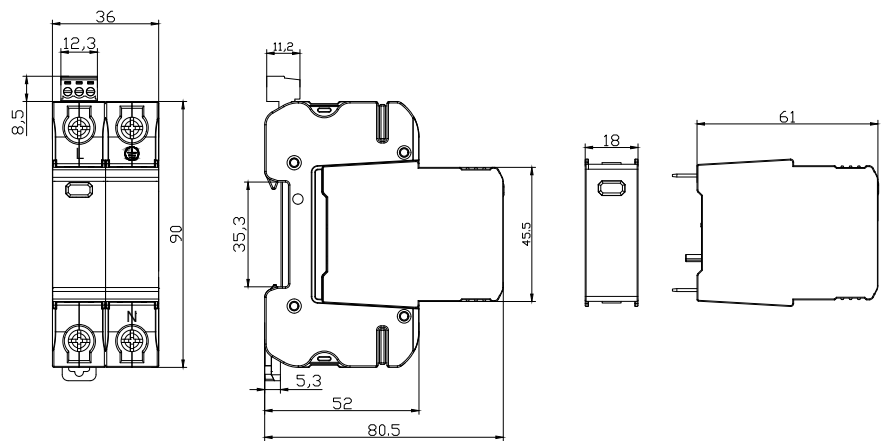

Connection Diagram

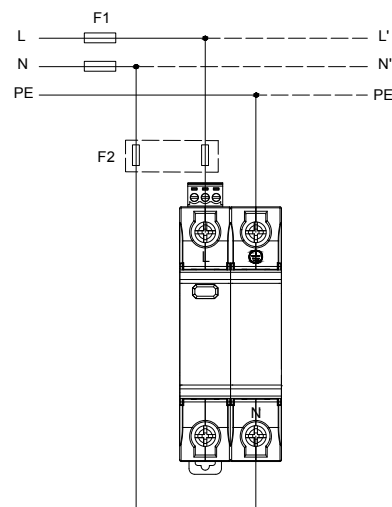

LY1-12.5/3(S)+1 Pluggable Multi-Pole SPD



Class I • Class II • Type 1 • Type 2

Location of Use: Main Distribution Boards

Mode of Protection: L-N, N-PE

Surge Ratings: $I_{imp} = 12.5 \text{ kA} (10/350 \mu\text{s})$

$I_n = 20 \text{ kA} (8/20 \mu\text{s})$

IEC/EN/UL Category: Class I+II / Type 1+2

Protective Elements: High Energy MOV and GDT

Housing: Pluggable Design

Compliance: IEC 61643-11:2011

EN 61643-11:2012

UL 1449 4th Edition

■ Technical Data

IEC Electrical			150	275	320
Nominal AC Voltage (50/60Hz)		U_o / U_n	120 V	230 V	230 V
Maximum Continuous Operating Voltage (AC)	(L-N)	U_c	150 V	275 V	320 V
	(N-PE)	U_c	255 V	255 V	255 V
Nominal Discharge Current (8/20 μs)	(L-N) / (N-PE)	I_n		20 kA / 50 kA	
Maximum Discharge Current (8/20 μs)	(L-N) / (N-PE)	I_{max}		50 kA / 100 kA	
Impulse Discharge Current (10/350 μs)	(L-N) / (N-PE)	I_{imp}		12.5 kA / 50 kA	
Specific Energy	(L-N) / (N-PE)	W/R		39 kJ/ Ω / 625 kJ/ Ω	
Charge	(L-N) / (N-PE)	Q		6.25 As / 25 As	
Voltage Protection Level	(L-N) / (N-PE)	U_p	1 kV / 1.5 kV	1.5 kV / 1.5 kV	1.6 kV / 1.5 kV
	(N-PE)	I_{R1}		100 A _{RMS}	
Response Time	(L-N) / (N-PE)	t_A		< 25 ns / < 100 ns	
Back-Up Fuse (max)				315 A / 250 A gG	
Short-Circuit Current Rating (AC)	(L-N)	I_{SCCR}		25 kA / 50 kA	
TOV Withstand 5s	(L-N)	U_T	180 V	335 V	335 V
TOV 120min	(L-N)	U_T	230 V	440 V	440 V
		mode	Safe Fail	Safe Fail	Safe Fail
TOV Withstand 200ms	(N-PE)	U_T		1200 V	
UL Electrical					
Maximum Continuous Operating Voltage (AC)	(L-N) / (N-PE)	MCOV	150 V / 255 V	275 V / 255 V	320 V / 255 V
Voltage Protection Rating	(L-N) / (N-PE)	VPR	600 V / 1200 V	900 V / 1200 V	1200 V / 1200 V
Nominal Discharge Current (8/20 μs)	(L-N) / (N-PE)	I_n	20 kA / 20 kA	20 kA / 20 kA	20 kA / 20 kA
Short-Circuit Current Rating (AC)	(L-N)	SCCR	200 kA	150 kA	150 kA
Mechanical & Environmental					
Operating Temperature Range		T_a		-40°F to +158°F [-40°C to +70°C]	
Permissible Operating Humidity		RH		5%...95%	
Atmospheric pressure and altitude				80k Pa ... 106k Pa / -500 m....2000 m	
Terminal Screw Torque		M_{max}		39.9 lbf-in [4.5 Nm]	
Conductor Cross Section (max)				2 AWG (Solid, Stranded) / 4 AWG (Flexible)	
				35 mm ² (Solid, Stranded) / 25 mm ² (Flexible)	
Mounting				35 mm DIN Rail, EN 60715	
Degree of Protection				IP 20 (built-in)	
Housing Material				Thermoplastic: Extinguishing Degree UL 94 V-0	
Thermal Protection				Yes	
Operating State / Fault Indication				Green ok / Red defect	
Remote Contacts (RC)				Optional	
RC Switching Capacity				AC: 250V / 0.5 A; DC: 250V / 0.1 A; 125 V / 0.2 A; 75 V / 0.5 A	
RC Conductor Cross Section (max)				16 AWG (Solid) / 1.5 mm ² (Solid)	

LY1-12.5/3(S)+1

Pluggable Multi-Pole SPD



Internal Configuration

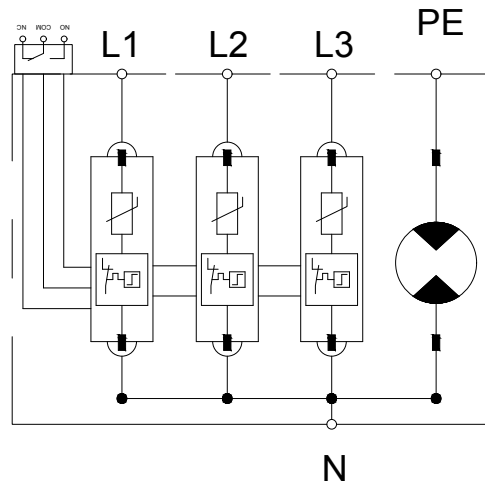

Dimensions & Packaging

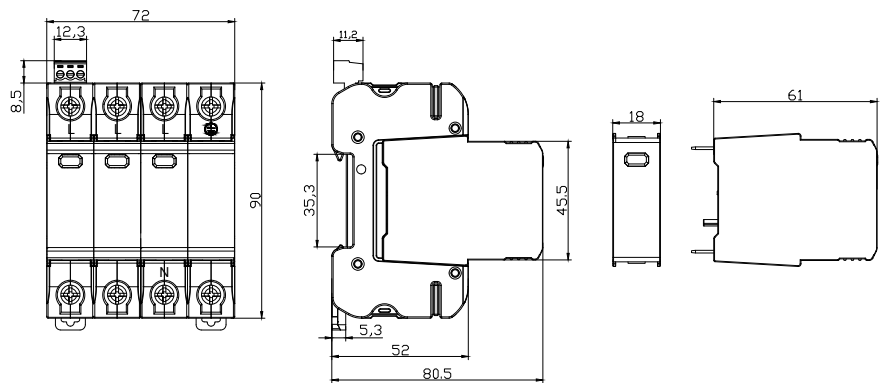

Connection Diagram

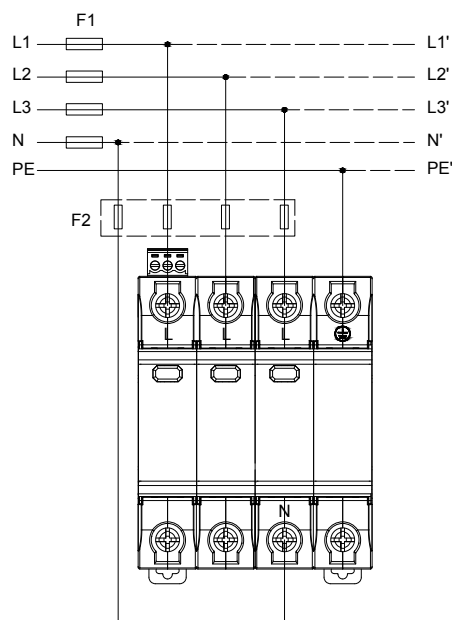

LY1-B25/1(S) Monoblock Single-Pole SPD



Class I • Class II • Type 1 • Type 2

Location of Use: Main Distribution Boards

Network Systems: TN-S, TN-C, TT

Mode of Protection: L-PE / N-PE

Surge Ratings: $I_{imp} = 25 \text{ kA} (10/350 \mu\text{s})$

$I_n = 25 \text{ kA} (8 / 20 \mu\text{s})$

IEC/EN Category: Class I+II / Type 1+2

Protective Elements: High Energy MOV

Housing: Monoblock Design

Compliance: IEC 61643-11:2011

EN 61643-11:2012

■ Technical Data

IEC Electrical		150	275	320	385	440
Nominal AC Voltage (50/60Hz)	U_o / U_n	120 V	230 V	230 V	230 V	400 V
Maximum Continuous Operating Voltage (AC)	U_c	150 V	275 V	320 V	385 V	440 V
Nominal Discharge Current (8/20 μs)	I_n			25kA		
Maximum Discharge Current (8/20 μs)	I_{max}			100kA		
Impulse Discharge Current (10/350 μs)	I_{imp}			25kA		
Specific Energy	W/R			156 kJ / Ω		
Charge	Q			12.5 As		
Voltage Protection Level	U_p	1 kV	1.5 kV	1.6 kV	1.8 kV	2 kV
Response Time	t_A			< 25 ns		
Back-Up Fuse (max)				315 A gL / gG		
Short-Circuit Current Rating (AC)	I_{SCCR}			50 kA		
TOV Withstand 5s	U_T	180V	335V	335V	335V	580V
TOV 120min	U_T	230V	440V	440V	440V	765V
Number of Ports				1		
Mechanical & Environmental						
Operating Temperature Range	T_a	-40°F to +158°F [-40°C to +70°C]				
Permissible Operating Humidity	RH	5%...95%				
Atmospheric pressure and altitude		80k Pa ... 106k Pa / -500 m.....2000 m				
Terminal Screw Torque	M_{max}	26.5 lbf-in [3.0 Nm]				
Conductor Cross Section (max)		2 AWG (Solid, Stranded) / 4 AWG (Flexible)				
		35 mm ² (Solid, Stranded) / 25 mm ² (Flexible)				
Mounting		35 mm DIN Rail, EN 60715				
Degree of Protection		IP 20 (built-in)				
Housing Material		Thermoplastic: Extinguishing Degree UL 94 V-0				
Thermal Protection		Yes				
Operating State / Fault Indication		Green ok / Red defect				
Remote Contacts (RC)		Optional				
RC Switching Capacity		AC: 250V / 0.5 A; DC: 250V / 0.1 A; 125 V / 0.2 A; 75 V / 0.5 A				
RC Conductor Cross Section (max)		16 AWG (Solid) / 1.5 mm ² (Solid)				

LY1-B25/1(S)

Monoblock Single-Pole SPD



Internal Configuration

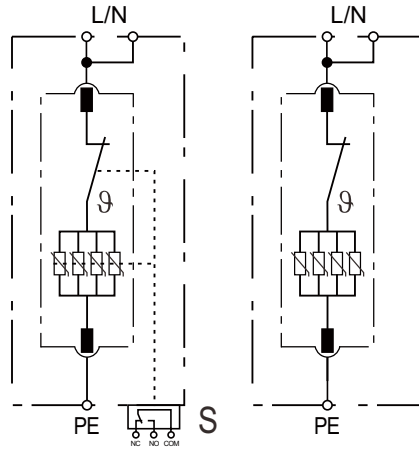

Dimensions & Packaging

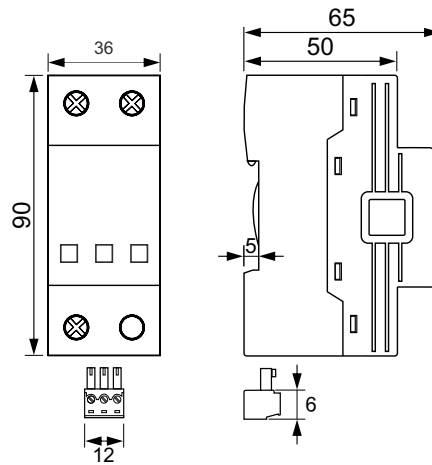

Connection Diagram

TN-S, TN-C, TT (Single-phase, 1+0)

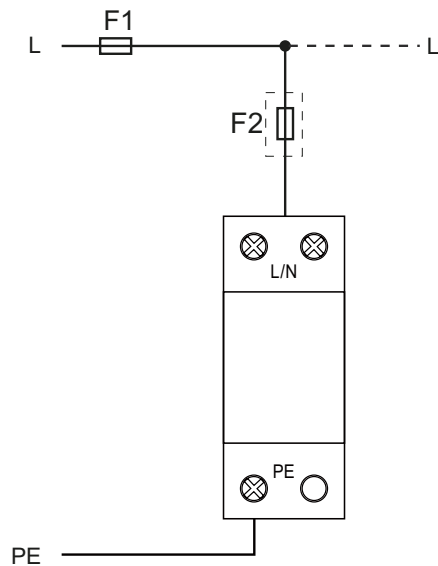



Class I • Class II • Type 1 • Type 2

Location of Use: Main Distribution Boards
 Network Systems: TN-S
 Mode of Protection: L-PE / L'-PE, N-PE / N'-PE
 Surge Ratings: $I_{imp} = 25 \text{ kA} (10/350 \mu\text{s})$
 $I_n = 25 \text{ kA} (8/20 \mu\text{s})$
 IEC/EN Category: Class I+II / Type 1+2
 Protective Elements: High Energy MOV
 Housing: Monoblock Design
 Compliance: IEC 61643-11:2011
 EN 61643-11:2012

■ Technical Data

IEC Electrical		150	275	320	385	440
Nominal AC Voltage (50/60Hz)	U_o / U_n	120 V	230 V	230 V	230 V	400 V
Maximum Continuous Operating Voltage (AC)	U_c	150 V	275 V	320 V	385 V	440 V
Nominal Discharge Current (8/20 μs)	I_n			25kA		
Maximum Discharge Current (8/20 μs)	I_{max}			100kA		
Impulse Discharge Current (10/350 μs)	I_{imp}			25kA		
Total Discharge Current (10/350 μs)	I_{total}			50 kA		
Specific Energy	W/R			156 kJ / Ω		
Charge	Q			12.5 As		
Voltage Protection Level	U_p	1 kV	1.5 kV	1.6 kV	1.8 kV	2 kV
Response Time	t_A			< 25 ns		
Back-Up Fuse (max)				315 A gL / gG		
Short-Circuit Current Rating (AC)	I_{SCCR}			50 kA		
TOV Withstand 5s	U_T	180V	335V	335V	335V	580V
TOV 120min	U_T	230V	440V	440V	440V	765V
Number of Ports				1		
Mechanical & Environmental						
Operating Temperature Range	T_a	-40°F to +158°F [-40°C to +70°C]				
Permissible Operating Humidity	RH	5%...95%				
Atmospheric pressure and altitude		80k Pa ... 106k Pa / -500 m.....2000 m				
Terminal Screw Torque	M_{max}	26.5 lbf·in [3.0 Nm]				
Conductor Cross Section (max)		2 AWG (Solid, Stranded) / 4 AWG (Flexible)				
		35 mm ² (Solid, Stranded) / 25 mm ² (Flexible)				
Mounting		35 mm DIN Rail, EN 60715				
Degree of Protection		IP 20 (built-in)				
Housing Material		Thermoplastic: Extinguishing Degree UL 94 V-0				
Thermal Protection		Yes				
Operating State / Fault Indication		Green ok / Red defect				
Remote Contacts (RC)		Optional				
RC Switching Capacity		AC: 250V / 0.5 A; DC: 250V / 0.1 A; 125 V / 0.2 A; 75 V / 0.5 A				
RC Conductor Cross Section (max)		16 AWG (Solid) / 1.5 mm ² (Solid)				

LY1-B25/2(S)

Monoblock Multi-Pole SPD



Internal Configuration

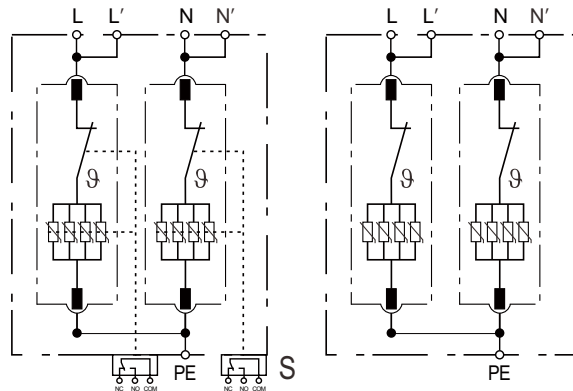

Dimensions & Packaging

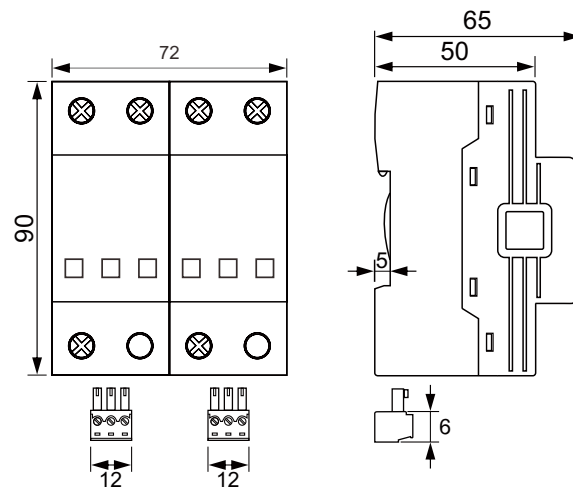

Connection Diagram

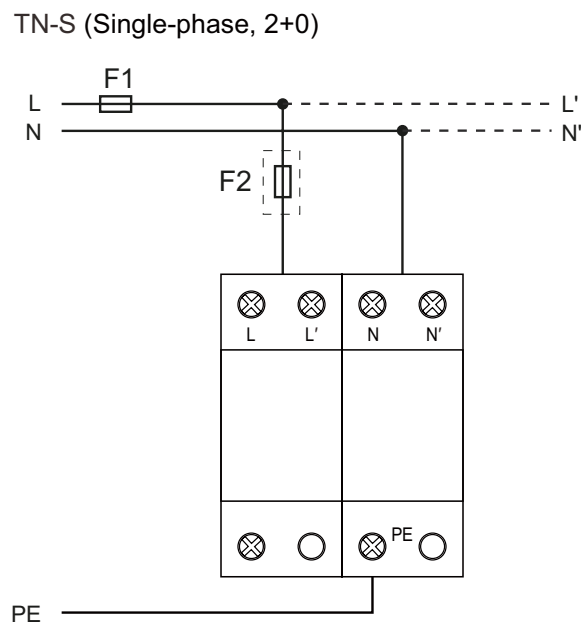

LY1-B25/3(S) Monoblock Multi-Pole SPD



Class I • Class II • Type 1 • Type 2

Location of Use: Main Distribution Boards

Network Systems: TN-C

Mode of Protection: L-PE / L'-PE

Surge Ratings: $I_{imp} = 25 \text{ kA} (10/350 \mu\text{s})$

$I_n = 25 \text{ kA} (8/20 \mu\text{s})$

IEC/EN Category: Class I+II / Type 1+2

Protective Elements: High Energy MOV

Housing: Monoblock Design

Compliance: IEC 61643-11:2011

EN 61643-11:2012

■ Technical Data

IEC Electrical		150	275	320	385	440
Nominal AC Voltage (50/60Hz)	U_o / U_n	120 V	230 V	230 V	230 V	400 V
Maximum Continuous Operating Voltage (AC)	U_c	150 V	275 V	320 V	385 V	440 V
Nominal Discharge Current (8/20 μs)	I_n			25kA		
Maximum Discharge Current (8/20 μs)	I_{max}			100kA		
Impulse Discharge Current (10/350 μs)	I_{imp}			25kA		
Total Discharge Current (10/350 μs)	I_{total}			75 kA		
Specific Energy	W/R			156 kJ / Ω		
Charge	Q			12.5 As		
Voltage Protection Level	U_p	1 kV	1.5 kV	1.6 kV	1.8 kV	2 kV
Response Time	t_A			< 25 ns		
Back-Up Fuse (max)				315 A gL / gG		
Short-Circuit Current Rating (AC)	I_{SCCR}			50 kA		
TOV Withstand 5s	U_T	180V	335V	335V	335V	580V
TOV 120min	U_T	230V	440V	440V	440V	765V
Number of Ports				1		
Mechanical & Environmental						
Operating Temperature Range	T_a	-40°F to +158°F [-40°C to +70°C]				
Permissible Operating Humidity	RH	5%...95%				
Atmospheric pressure and altitude		80k Pa ... 106k Pa / -500 m.....2000 m				
Terminal Screw Torque	M_{max}	26.5 lbf·in [3.0 Nm]				
Conductor Cross Section (max)		2 AWG (Solid, Stranded) / 4 AWG (Flexible)				
		35 mm ² (Solid, Stranded) / 25 mm ² (Flexible)				
Mounting		35 mm DIN Rail, EN 60715				
Degree of Protection		IP 20 (built-in)				
Housing Material		Thermoplastic: Extinguishing Degree UL 94 V-0				
Thermal Protection		Yes				
Operating State / Fault Indication		Green ok / Red defect				
Remote Contacts (RC)		Optional				
RC Switching Capacity		AC: 250V / 0.5 A; DC: 250V / 0.1 A; 125 V / 0.2 A; 75 V / 0.5 A				
RC Conductor Cross Section (max)		16 AWG (Solid) / 1.5 mm ² (Solid)				

LY1-B25/3(S)

Monoblock Multi-Pole SPD



Internal Configuration

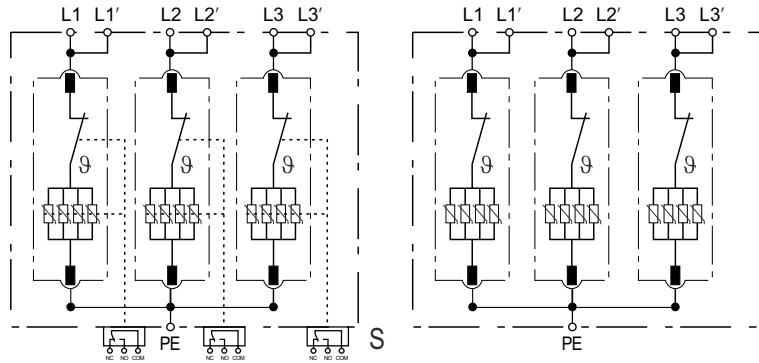

Dimensions & Packaging

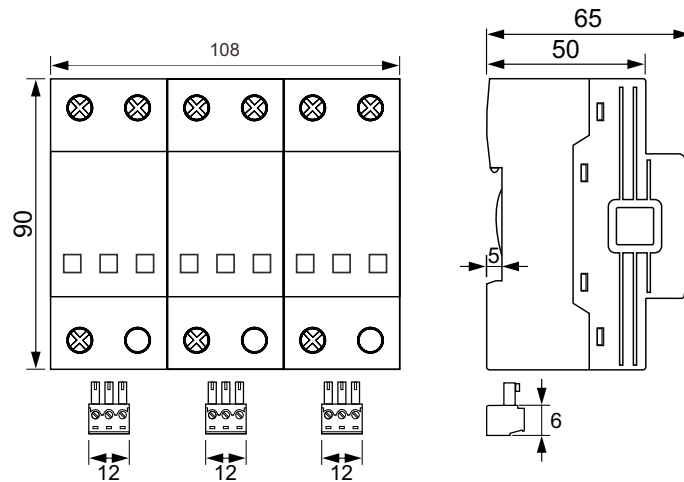

Connection Diagram

TN-C (Three-phase, 3+0)

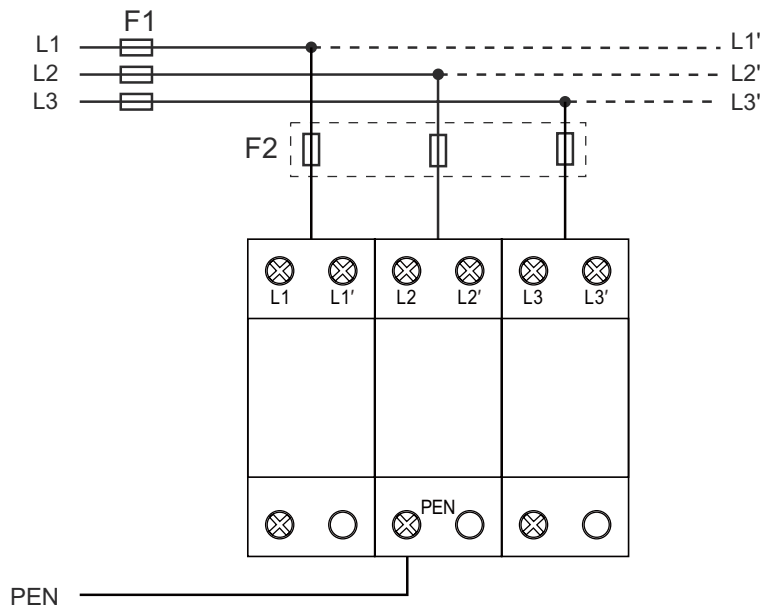

LY1-B25/4(S) Monoblock Multi-Pole SPD



Class I • Class II • Type 1 • Type 2

Location of Use: Main Distribution Boards
 Network Systems: TN-S
 Mode of Protection: L-PE / L'-PE, N-PE / N'-PE
 Surge Ratings: $I_{imp} = 25 \text{ kA}$ (10/350 μs)
 $I_n = 25 \text{ kA}$ (8 /20 μs)
 IEC/EN Category: Class I+II / Type 1+2
 Protective Elements: High Energy MOV
 Housing: Monoblock Design
 Compliance: IEC 61643-11:2011
 EN 61643-11:2012

■ Technical Data

IEC Electrical		150	275	320	385	440
Nominal AC Voltage (50/60Hz)	U_o / U_n	120 V	230 V	230 V	230 V	400 V
Maximum Continuous Operating Voltage (AC)	U_c	150 V	275 V	320 V	385 V	440 V
Nominal Discharge Current (8/20 μs)	I_n			25kA		
Maximum Discharge Current (8/20 μs)	I_{max}			100kA		
Impulse Discharge Current (10/350 μs)	I_{imp}			25kA		
Total Discharge Current (10/350 μs)	I_{total}			100 kA		
Specific Energy	W/R			156 kJ / Ω		
Charge	Q			12.5 As		
Voltage Protection Level	U_p	1 kV	1.5 kV	1.6 kV	1.8 kV	2 kV
Response Time	t_A			< 25 ns		
Back-Up Fuse (max)				315 A gL / gG		
Short-Circuit Current Rating (AC)	I_{SCCR}			50 kA		
TOV Withstand 5s	U_T	180V	335V	335V	335V	580V
TOV 120min	U_T	230V	440V	440V	440V	765V
Number of Ports				1		
Mechanical & Environmental						
Operating Temperature Range	T_a	-40°F to +158°F [-40°C to +70°C]				
Permissible Operating Humidity	RH	5%...95%				
Atmospheric pressure and altitude		80k Pa ... 106k Pa / -500 m.....2000 m				
Terminal Screw Torque	M_{max}	26.5 lbf·in [3.0 Nm]				
Conductor Cross Section (max)		2 AWG (Solid, Stranded) / 4 AWG (Flexible)				
		35 mm ² (Solid, Stranded) / 25 mm ² (Flexible)				
Mounting		35 mm DIN Rail, EN 60715				
Degree of Protection		IP 20 (built-in)				
Housing Material		Thermoplastic: Extinguishing Degree UL 94 V-0				
Thermal Protection		Yes				
Operating State / Fault Indication		Green ok / Red defect				
Remote Contacts (RC)		Optional				
RC Switching Capacity		AC: 250V / 0.5 A; DC: 250V / 0.1 A; 125 V / 0.2 A; 75 V / 0.5 A				
RC Conductor Cross Section (max)		16 AWG (Solid) / 1.5 mm ² (Solid)				

LY1-B25/4(S)

Monoblock Multi-Pole SPD



Internal Configuration

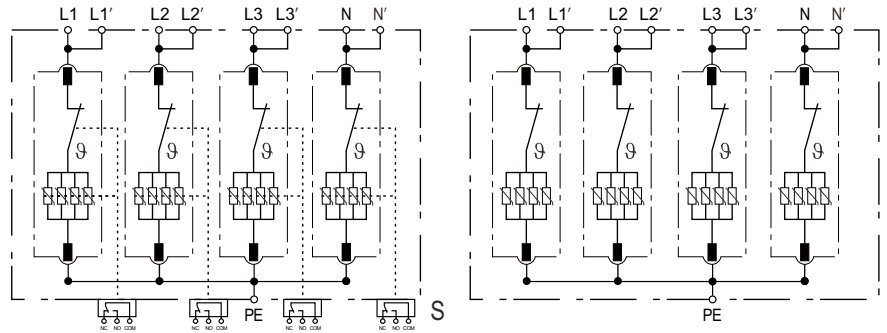

Dimensions & Packaging

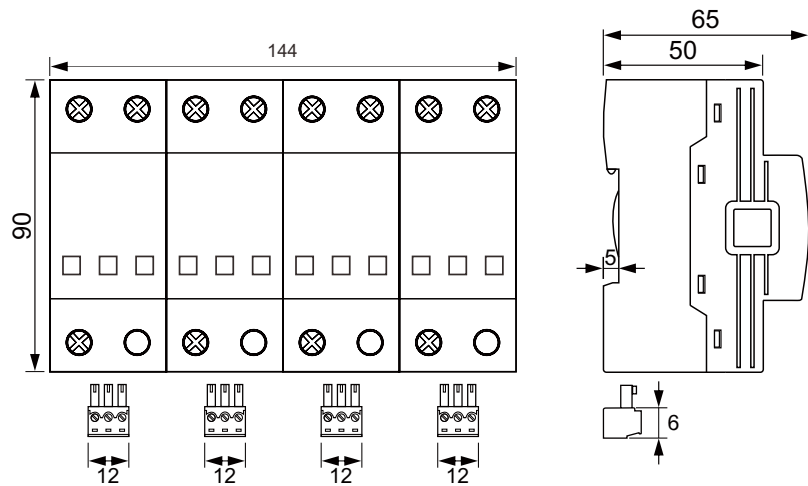

Connection Diagram

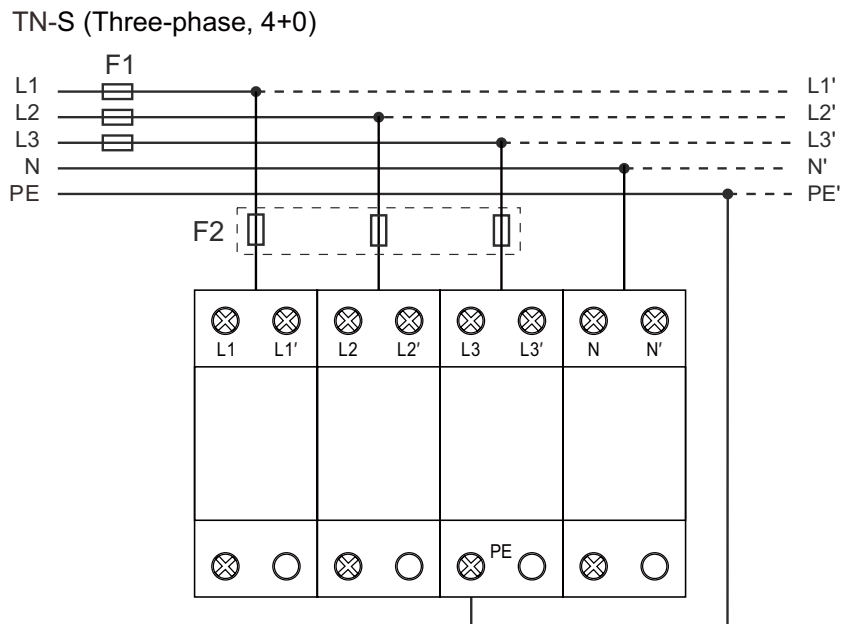



Class I • Class II • Type 1 • Type 2

Location of Use: Main Distribution Boards

Network Systems: TT, TN-S

Mode of Protection: L-N / L'-N, N-PE

Surge Ratings: $I_{imp} = 25 \text{ kA} / 50 \text{ kA} (10/350 \mu\text{s})$
 $I_n = 25 \text{ kA} / 50 \text{ kA} (8/20 \mu\text{s})$

IEC/EN Category: Class I+II / Type 1+2

Protective Elements: High Energy MOV and GDT

Housing: Monoblock Design

Compliance: IEC 61643-11:2011

EN 61643-11:2012

■ Technical Data

IEC Electrical			150	275	320	385
Nominal AC Voltage (50/60Hz)		U_o / U_n	120 V	230 V	230 V	230 V
Maximum Continuous Operating Voltage (AC)	(L-N)	U_c	150 V	275 V	320 V	380 V
	(N-PE)	U_c	255 V	255 V	255 V	255 V
Nominal Discharge Current (8/20 μs)	(L-N) / (N-PE)	I_n		25 kA / 50 kA		
Maximum Discharge Current (8/20 μs)	(L-N) / (N-PE)	I_{max}		100 kA		
Impulse Discharge Current (10/350 μs)	(L-N) / (N-PE)	I_{imp}		25 kA / 50 kA		
Total Discharge Current (10/350 μs)		I_{total}		50 kA		
Specific Energy	(L-N) / (N-PE)	W/R		156 kJ / Ω / 625 kJ / Ω		
Charge	(L-N) / (N-PE)	Q		12.5 As / 25 As		
Voltage Protection Level	(L-N) / (N-PE)	U_p	1 kV / 1.5 kV	1.5 kV / 1.5 kV	1.6 kV / 1.5 kV	1.8 kV / 1.5 kV
	(N-PE)	I_{ri}		100 A _{RMS}		
Response Time	(L-N) / (N-PE)	t_A		< 25 ns / < 100 ns		
Back-Up Fuse (max)				315 A gL / gG		
Short-Circuit Current Rating (AC)	(L-N)	I_{SCCR}		50 kA		
TOV Withstand 5s	(L-N)	U_T	180 V	335 V	335 V	335 V
TOV 120min	(L-N)	U_T	230 V	440 V	440 V	440 V
TOV Withstand 200ms	(N-PE)	U_T		1200 V		
Number of Ports				1		
Mechanical & Environmental						
Operating Temperature Range		T_a		-40°F to +158°F [-40°C to +70°C]		
Permissible Operating Humidity		RH		5%...95%		
Atmospheric pressure and altitude				80k Pa ... 106k Pa / -500 m.....2000 m		
Terminal Screw Torque		M_{max}		39.9 lbf-in [4.5 Nm]		
Conductor Cross Section (max)				2 AWG (Solid, Stranded) / 4 AWG (Flexible)		
				35 mm ² (Solid, Stranded) / 25 mm ² (Flexible)		
Mounting				35 mm DIN Rail, EN 60715		
Degree of Protection				IP 20 (built-in)		
Housing Material				Thermoplastic: Extinguishing Degree UL 94 V-0		
Thermal Protection				Yes		
Operating State / Fault Indication				Green ok / Red defect		
Remote Contacts (RC)				Optional		
RC Switching Capacity				AC: 250V / 0.5 A; DC: 250V / 0.1 A; 125 V / 0.2 A; 75 V / 0.5 A		
RC Conductor Cross Section (max)				16 AWG (Solid) / 1.5 mm ² (Solid)		

LY1-B25/1(S)+1

Monoblock Multi-Pole SPD



Internal Configuration

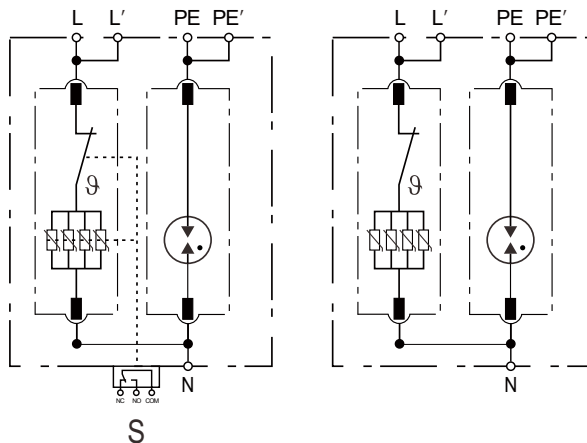

Dimensions & Packaging

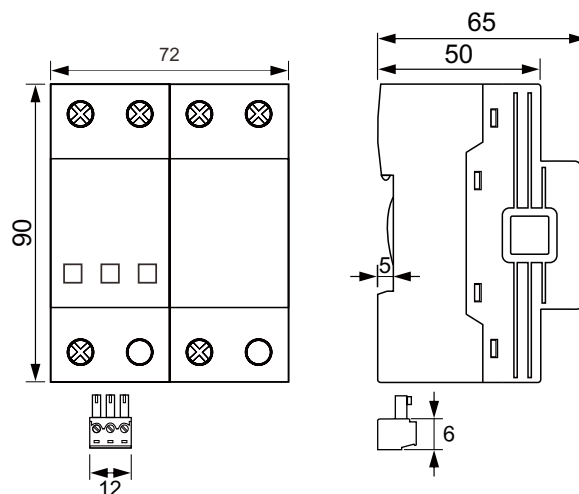

Connection Diagram

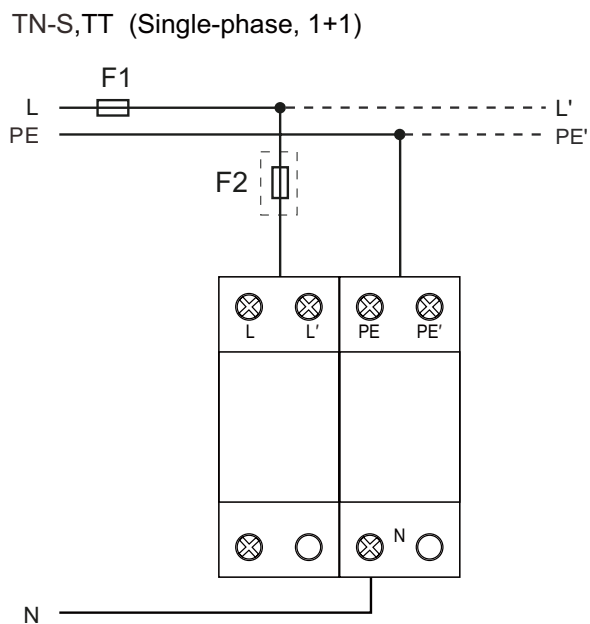



Class I • Class II • Type 1 • Type 2

Location of Use: Main Distribution Boards

Network Systems: TT, TN-S

Mode of Protection: L-N / L'-N, N-PE

Surge Ratings: $I_{imp} = 25 \text{ kA} / 100 \text{ kA} (10/350 \mu\text{s})$

$I_n = 25 \text{ kA} / 100 \text{ kA} (8/20 \mu\text{s})$

IEC/EN Category: Class I+II / Type 1+2

Protective Elements: High Energy MOV and GDT

Housing: Monoblock Design

Compliance: IEC 61643-11:2011

EN 61643-11:2012

■ Technical Data

IEC Electrical			150	275	320	385
Nominal AC Voltage (50/60Hz)		U_o / U_n	120 V	230 V	230 V	230 V
Maximum Continuous Operating Voltage (AC)	(L-N)	U_c	150 V	275 V	320 V	380 V
	(N-PE)	U_c	255 V	255 V	255 V	255 V
Nominal Discharge Current (8/20 μs)	(L-N) / (N-PE)	I_n	25 kA / 100 kA			
Maximum Discharge Current (8/20 μs)	(L-N) / (N-PE)	I_{max}	100 kA			
Impulse Discharge Current (10/350 μs)	(L-N) / (N-PE)	I_{imp}	25 kA / 100 kA			
Total Discharge Current (10/350 μs)		I_{total}	75 kA			
Specific Energy	(L-N) / (N-PE)	W/R	156 kJ / Ω / 2.5 M kJ / Ω			
Charge	(L-N) / (N-PE)	Q	12.5 As / 50 As			
Voltage Protection Level	(L-N) / (N-PE)	U_p	1 kV / 1.5 kV	1.5 kV / 1.5 kV	1.6 kV / 1.5 kV	1.8 kV / 1.5 kV
	(N-PE)	I_{fi}	100 A _{RMS}			
Response Time	(L-N) / (N-PE)	t_A	< 25 ns / < 100 ns			
Back-Up Fuse (max)			315 A gL / gG			
Short-Circuit Current Rating (AC)	(L-N)	I_{SCCR}	50 kA			
TOV Withstand 5s	(L-N)	U_T	180 V	335 V	335 V	335 V
TOV 120min	(L-N)	U_T	230 V	440 V	440 V	440 V
TOV Withstand 200ms	(N-PE)	U_T	1200 V			
Number of Ports			1			
Mechanical & Environmental						
Operating Temperature Range		T_a	-40°F to +158°F [-40°C to +70°C]			
Permissible Operating Humidity		RH	5%...95%			
Atmospheric pressure and altitude			80k Pa ... 106k Pa / -500 m.....2000 m			
Terminal Screw Torque		M_{max}	39.9 lbf-in [4.5 Nm]			
Conductor Cross Section (max)			2 AWG (Solid, Stranded) / 4 AWG (Flexible)			
			35 mm ² (Solid, Stranded) / 25 mm ² (Flexible)			
Mounting			35 mm DIN Rail, EN 60715			
Degree of Protection			IP 20 (built-in)			
Housing Material			Thermoplastic: Extinguishing Degree UL 94 V-0			
Thermal Protection			Yes			
Operating State / Fault Indication			Green ok / Red defect			
Remote Contacts (RC)			Optional			
RC Switching Capacity			AC: 250V / 0.5 A; DC: 250V / 0.1 A; 125 V / 0.2 A; 75 V / 0.5 A			
RC Conductor Cross Section (max)			16 AWG (Solid) / 1.5 mm ² (Solid)			

LY1-B25/2(S)+1

Monoblock Multi-Pole SPD



Internal Configuration

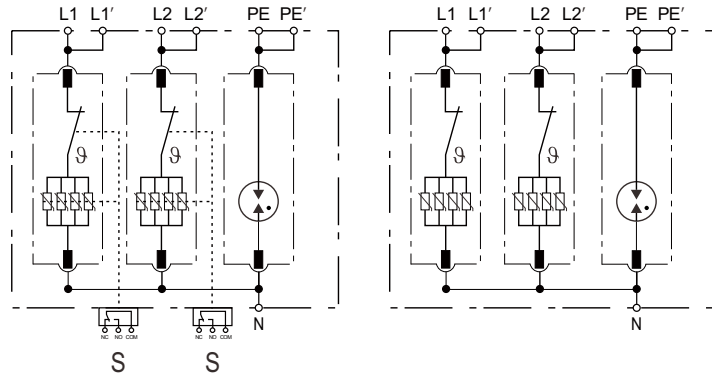

Dimensions & Packaging

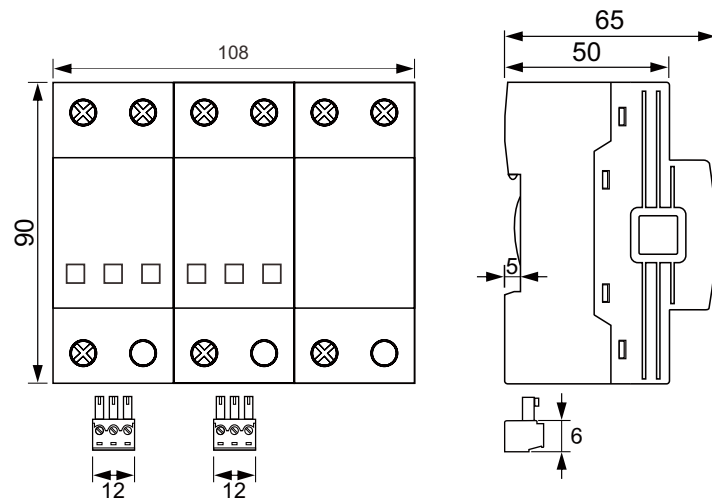

Connection Diagram

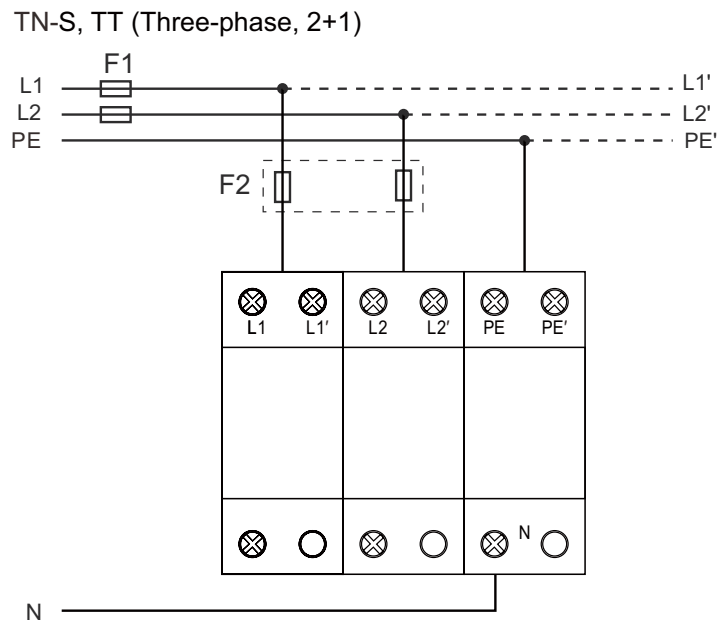



Class I • Class II • Type 1 • Type 2

Location of Use: Main Distribution Boards
 Network Systems: TT, TN-S
 Mode of Protection: L-N / L'-N, N-PE
 Surge Ratings: $I_{imp} = 25 \text{ kA} / 100 \text{ kA} (10/350 \mu\text{s})$
 $I_n = 25 \text{ kA} / 100 \text{ kA} (8/20 \mu\text{s})$
 IEC/EN Category: Class I+II / Type 1+2
 Protective Elements: High Energy MOV and GDT
 Housing: Monoblock Design
 Compliance: IEC 61643-11:2011
 EN 61643-11:2012

■ Technical Data

IEC Electrical			150	275	320	385
Nominal AC Voltage (50/60Hz)		U_o / U_n	120 V	230 V	230 V	230 V
Maximum Continuous Operating Voltage (AC)	(L-N)	U_c	150 V	275 V	320 V	380 V
	(N-PE)	U_c	255 V	255 V	255 V	255 V
Nominal Discharge Current (8/20 μs)	(L-N) / (N-PE)	I_n	25 kA / 100 kA			
Maximum Discharge Current (8/20 μs)	(L-N) / (N-PE)	I_{max}	100 kA			
Impulse Discharge Current (10/350 μs)	(L-N) / (N-PE)	I_{imp}	25 kA / 100 kA			
Total Discharge Current (10/350 μs)		I_{total}	100 kA			
Specific Energy	(L-N) / (N-PE)	W/R	156 kJ / Ω / 2.5 M kJ / Ω			
Charge	(L-N) / (N-PE)	Q	12.5 As / 50 As			
Voltage Protection Level	(L-N) / (N-PE)	U_p	1 kV / 1.5 kV	1.5 kV / 1.5 kV	1.6 kV / 1.5 kV	1.8 kV / 1.5 kV
	(N-PE)	I_{fi}	100 A _{RMS}			
Response Time	(L-N) / (N-PE)	t_A	< 25 ns / < 100 ns			
Back-Up Fuse (max)			315 A gL / gG			
Short-Circuit Current Rating (AC)	(L-N)	I_{SCCR}	50 kA			
TOV Withstand 5s	(L-N)	U_T	180 V	335 V	335 V	335 V
TOV 120min	(L-N)	U_T	230 V	440 V	440 V	440 V
TOV Withstand 200ms	(N-PE)	U_T	1200 V			
Number of Ports			1			
Mechanical & Environmental						
Operating Temperature Range		T_a	-40°F to +158°F [-40°C to +70°C]			
Permissible Operating Humidity		RH	5%...95%			
Atmospheric pressure and altitude			80k Pa ... 106k Pa / -500 m.....2000 m			
Terminal Screw Torque		M_{max}	26.5 lbf-in [3.0 Nm]			
Conductor Cross Section (max)			2 AWG (Solid, Stranded) / 4 AWG (Flexible)			
			35 mm ² (Solid, Stranded) / 25 mm ² (Flexible)			
Mounting			35 mm DIN Rail, EN 60715			
Degree of Protection			IP 20 (built-in)			
Housing Material			Thermoplastic: Extinguishing Degree UL 94 V-0			
Thermal Protection			Yes			
Operating State / Fault Indication			Green ok / Red defect			
Remote Contacts (RC)			Optional			
RC Switching Capacity			AC: 250V / 0.5 A; DC: 250V / 0.1 A; 125 V / 0.2 A; 75 V / 0.5 A			
RC Conductor Cross Section (max)			16 AWG (Solid) / 1.5 mm ² (Solid)			

LY1-B25/3(S)+1

Monoblock Multi-Pole SPD



Internal Configuration

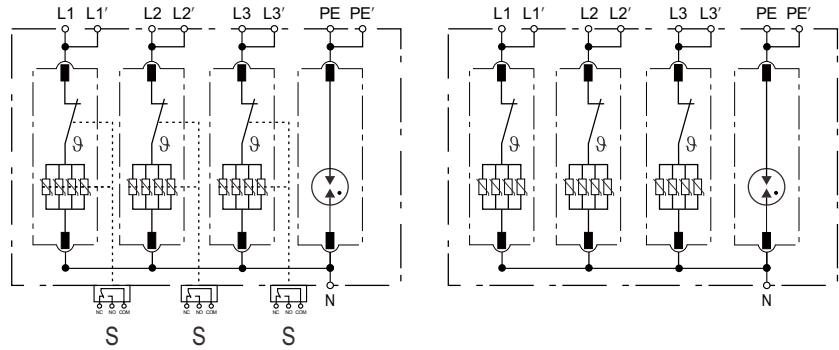

Dimensions & Packaging

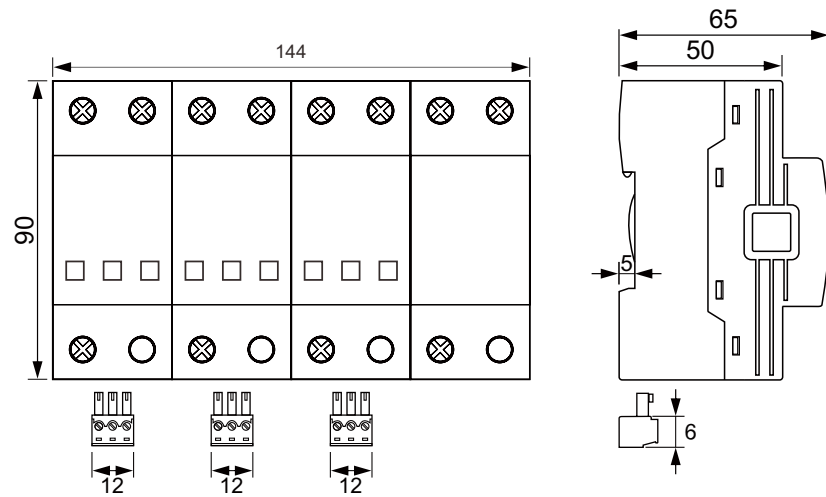

Connection Diagram

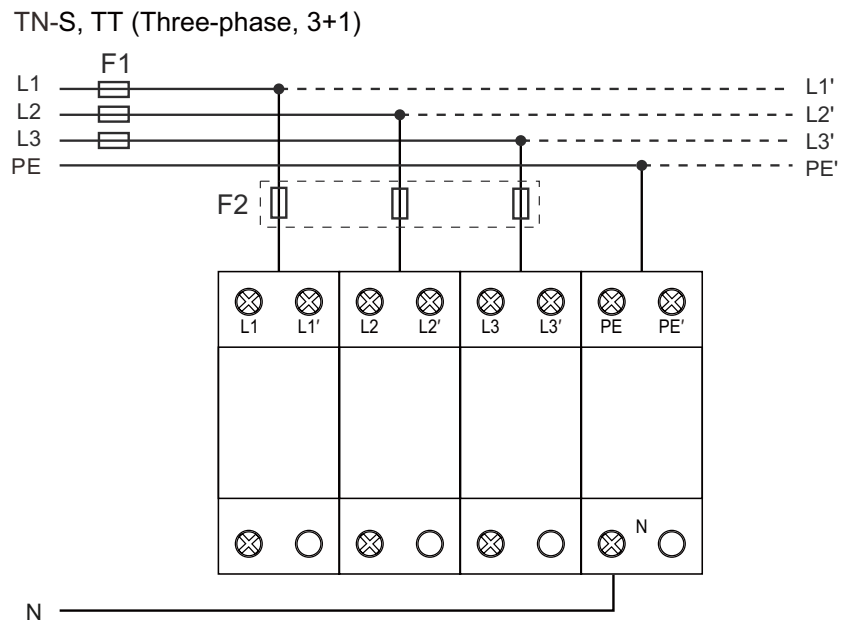



Type 1 + 2 + 3 AC surge protector for 40mm busbar systems

VG Technology

In : 20 kA

Iimp : 12,5kA

Iimp total : 50 kA on 10/350µs impulse

No leakage current

Pluggable module

Optimized to TOV

EN 61643-11, IEC 61643-11

■ Technical Data

Electrical Characteristics		
SPD type		1+2+3
Network		230/400 V 3-phase+N
AC system		TT-TNS
Nominal line voltage	U_n	230/400 Vac
Max. AC operating voltage	U_c	275 Vac
Temporary Over Voltage (TOV) Characteristics - 5 sec. Without disconnection	U_T	335 Vac withstand
Temporary Over Voltage (TOV) Characteristics - 120 mn Without disconnection or with safety disconnection	U_T	770 Vac withstand
Temporary Over Voltage N/PE (TOV HT) Without disconnection or with safety disconnection	U_T	1.2 kV/300A/200 ms withstand
Residual Current Leakage current to Ground	I_{pe}	None
Follow current	I_f	None
Nominal discharge current 15 x 8/20 µs impulses	I_n	20 kA
Max. discharge current max. withstand @ 8/20 µs by pole	I_{max}	50 kA
Impulse current by pole max. withstand 10/350µs by pole	I_{imp}	12.5 kA
Total lightning currentmax. total withstand @ 10/350µs	I_{total}	50 kA
Withstand on Combination waveform IEC 61643-11 Class III test: 1.2/50µs - 8/20µs	U_{oc}	6 kV
Withstand on overvoltages IEEE C62.41.1		20 kV
Specific energy by pole max. withstand 10/350 µs	W/R	40 kJ/ohm
Connection mode(s)		L/N and N/PE
Protection mode(s)		Common/Differential mode
Protection level L/N @ In (8/20µs)	U_p L/N	1.5 kV
Protection level L/PE @ In (8/20µs)	U_p L/PE	1.5 kV
Residual voltage L/N at 5 kA @ 5 kA (8/20µs)	U_p -5kA	0.7 kV
Admissible short-circuit current	I_{SCCR}	50 kA
Mechanical Characteristics		
Technology		VG Technology (MOV+GSG)
SPD configuration		3-phase+Neutral
Connection to Network		By 40mm busbar and wire for PE: 6-35mm ² (50mm ²)
Format		Plug-in modular box
Mounting		40 mm busbar systems
Housing material		Thermoplastic UL94 V-0
Operating temperature	T_u	-40/+85°C
Protection rating		IP20
Outdoor application		No
Failsafe modem		Disconnection from AC network
Disconnection indicator		1 mechanical indicator by pole
Remote signaling of disconnection		Yes
Dimensions		See diagram
Weight		0.7401 kg
Disconnectors		
Thermal disconnector		Internal
Installation ground fault breaker		Type 'S' or delayed
Fuses		max. 315 A (gL/gG)
Standards		
Standards compliance		IEC 61643-11 / EN 61643-11 / UL1449 4ed.

LYB-12.5/275

Pluggable Multi-Pole SPD



■ Dimensions & Packaging

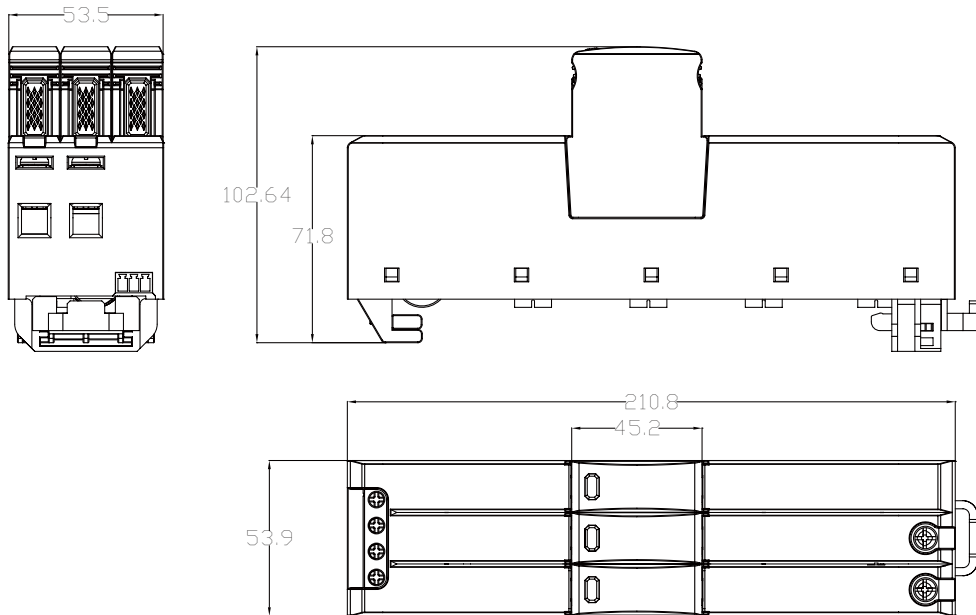

■ Product features



- 1.Parameters control the trip mechanism, and it achieves selective analysis on the through-current;
- 2.Low residual voltage of the surge current, can compare with fuse
- 3.High-energy contacts with long service life;
- 4.Compact appearance and small size are easy to cut off power supply to support SPD;
- 5.Full specifications meet the SPD on T1,T2 and T3 levels;
- 6.35mm standard din rail installation,meets different countries installation requirements.

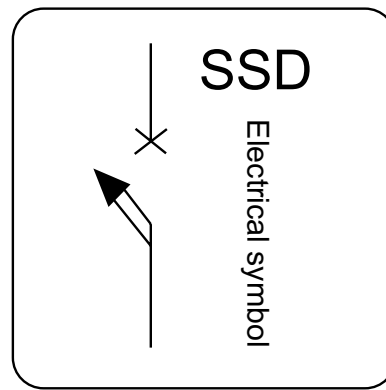

■ Applications

- 1.Breaking off through power frequency current and lightning current, effectively protects SPD from fusing short-circuit due to abnormal transient overvoltage, prevents from serious fire accidents.
- 2.Achieved selective breaking off for throughed frequency current and lightning current.effectively protects SPD from deterioration resulting in start voltage falling to less than the power supply voltage and increasing of leakage current, prevents from serious fire accidents.
- 3.When SPD has a lightning current,the external disconnecter wil not be tripped by mistake, so that lightning protection of electrical equipment is always in valid state.

■ Scope of application

SCB-SPD special backup protector provides professional backup protection for SPD(Surge Protection Device) which provides protection for the first level, second level and third-level equipment it is suitable for places where SPD lightning protection equipment has been installed,such as power equipment in industrial and residential buildings, electrical, communications, road and transportation, petrochemical and other industries.

Specifications

Spec. & Model	LYSCB-20	LYSCB-40	LYSCB-60	LYSCB-80	LYSCB-100	LYSCB-15G
Non-trip impulse current I_e	20kA(8/20)	40kA(8/20)	60kA(8/20)	80kA(8/20)	100kA(8/20)	15kA(8/350)
Non-trip impulse current withstand capacity	10kA(8/20)16 times 20kA(8/20)2 times	20kA(8/20)16 times 40kA(8/20)2 times	40kA(8/20)16 times 60kA(8/20)2 times	60kA(8/20)16 times 80kA(8/20)2 times	80kA(8/20)16 times 100kA(8/20)2 times	Meet the standard GB18802.1-2011 test level T1
Electrical symbol						
Rated operating voltage U_e	230VAC					
Rated insulation voltage U_i	400VAC					
Current tripping value I_o	3±1A					
Running short-circuit capacity $I_{cs}(\cos\phi 0.20\sim 0.25)$	6kA/20kA	6kA/20kA	6kA/20kA	6kA/35kA	50kA/100kA	50kA/100kA
Power frequency short-circuit current breaking time T_{cs}	≤40ms					
Power frequency load current breaking time T_o	≤50ms					
Mechanical life	≤4000times					
Electrical life	≤4000times					
Shell IP code	IP20					
Screw	M5					
Min. area of connecting cable	2.5mm ² /flexible					
Max. area of connecting cable	25mm ² /flexible					
Max. allowable operating current of remote-signaling contact	2A/250VAC NO or NC (default NC)					
Shell material	PBT UL94VO					
Outline dim	91×73×17.8mm					
Protection action and ambient temperature	-25°C ~-60°C inside switch					
Storage condition	Temperature -40°C ~-75°C , relative humidity: <95%(at 25°C)					
Service condition	Temperature -25°C ~-60°C , relative humidity: <95%(at 25°C)					
Shell color	Shell: blue Handle: orange					
Mounting rail	EN60715(35mm)					

Order guide

Model	Protection level	I_{imp}/I_n	Width(W)	Electrical symbol
LYSCB-15G	T1	≤25kA(10/350μs)	35mm	
		≤15kA(10/350μs)	18mm	
LYSCB-100	T2	≤60kA(8/20μs)	18mm	
LYSCB-80				
LYSCB-60	T2/T3	≤20kA(8/20μs)	18mm	
LYSCB-40				
LYSCB-20				

LY10

Data signal/DC surge protective device

■ Product overview

LY10 series surge protective device is in series in front of protected equipment, mainly used in communication lines, telemetry signals, remote control signals etc. signal equipment protection. It can suppress induced over-voltage on the signal lines and protect equipment from hazards lightning induction.



■ Features

1. Large flow tolerance, multilevel protection.
2. Fast response, low limit voltage.
3. Protect a pair of signal lines.
4. Low insertion loss.
5. A variety of protection rated voltage for selection.

■ Specifications

Model	LY10		
Rated operating voltage	12V	24V	48V
Max continuous operating voltage	15V	30V	60V
Rated load current	500mA		
Flow withstand capacity	10KV&5KA		
Clamping voltage x-x (1.2/50)	60V	80V	160V
Transmission rate	10Mbps		
Insertion loss	≤0.2dB		
Interface type	Connection terminal		
Protection grade	IP20		

■ Outline dimensions

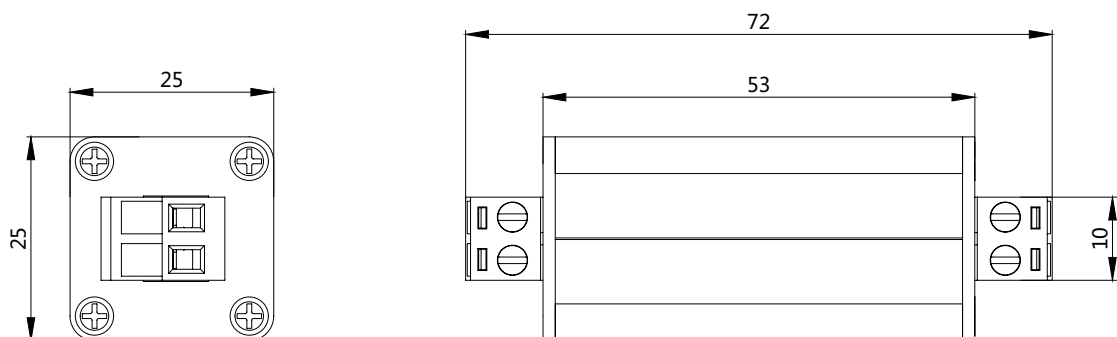

LY10

Data signal/DC surge protective device



■ Specifications

Model	LY10		
Spec	Din rail plug in type		
Rated operating voltage	12V	24V	48V
Max continuous operating voltage	15V	30V	60V
Rated load current	500mA		
Flow withstand capacity	10KV&5KA		
Clamping voltage x-x (1.2/50)	60 V	80 V	160 V
Transmission rate	10Mbps		
Insertion loss	≤0.2dB		
Interface type	Connection terminal		
Protection grade	IP20		

■ Outline dimensions

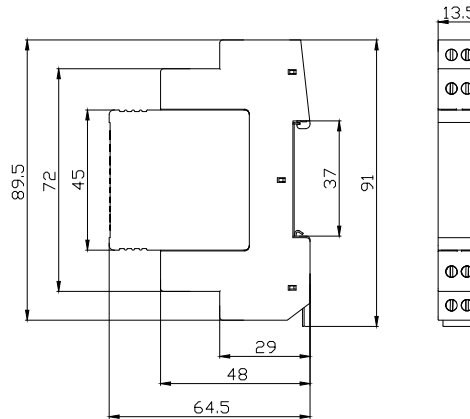

■ Specifications

Model	LY10		
Installations	DIN rail		
Rated operating voltage	12V	24V	48V
Max continuous operating voltage	15V	30V	60V
Rated load current	500mA		
Flow withstand capacity	10KV&5KA		
Clamping voltage x-x (1.2/50)	60V	80V	160V
Transmission rate	10Mbps		
Insertion loss	≤0.2dB		
Type of Connection IN/OUT	Screw		
Protection grade	IP20		

■ Outline dimensions

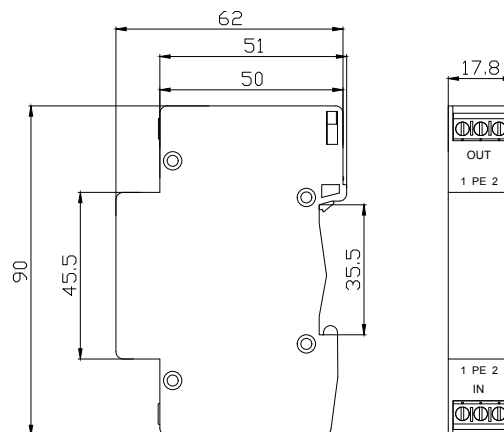

LY11

RS232 surge protective device

■ Product overview

LY11 series signal surge protection device is RS232,RS485/422,wired remote sensing,telemetering sensing,telemetering,remote control equipment etc. There has 9pins and 25pins interface.Supply.line-line,line-ground surge protection. Easy install,no need maintenance,fast response, could fully protect the equipment.



■ Features

- 1.Accurate protection to communication line.
- 2.Quick response, low clamping voltage.
- 3.Transmission characteristic: 1Mbps.
- 4.Low insertion loss.

■ Specifications

Model	LY11	
Rated operating voltage	9V	
Max continuous operating voltage	15V	
Rated load current	500mA	
Flow withstand capacity	1KV&0.5KA	
Clamping voltage x-x (1.2/50)	60V	
Transmission rate	1Mbps	
Insertion loss	≤0.2dB	
Interface type	DB9	DB25
Protection circuit	9-pin	25-pin
Protection grade	IP20	

■ Outline dimensions

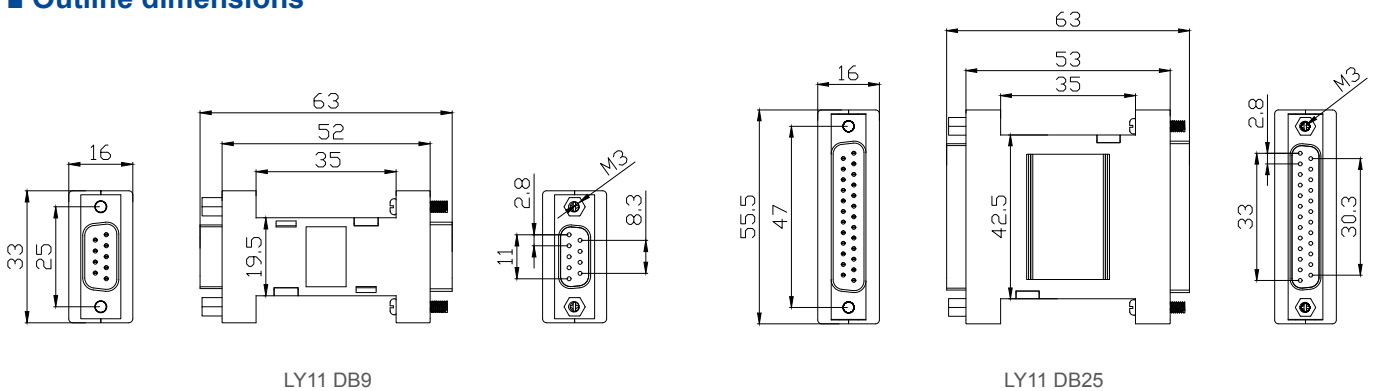

LY21-1

RJ11 telephone surge protective device



LY21-1

■ Product overview

LY21-1 series signal lightning protective device is connected in series in front of the protected equipment, it is mainly used for overvoltage protection intruded through a variety of audio signal lines into the device, such as SPC exchange, fax equipment, MODEM, emergency phones, relay lines and so on.

■ Features

1. Large tolerance to through-current, it adopts multi-level protection.
2. Fast response and low limit voltage.
3. Low insertion loss.
4. Many types of protective rated voltage for option.

■ Specifications

Model	LY10		
Rated operating voltage	45V	130V	170V
Max continuous operating voltage	60V	150V	185V
Rated load current	500mA		
Flow withstand capacity	5KV&2.5KA		
Clamping voltage x-x(1.2/50)	160V/240V/300V		
Transmission rate	2Mbps		
Insertion loss	≤0.2dB		
Interface type	RJ11		
Protection grade	IP20		

■ Outline dimensions

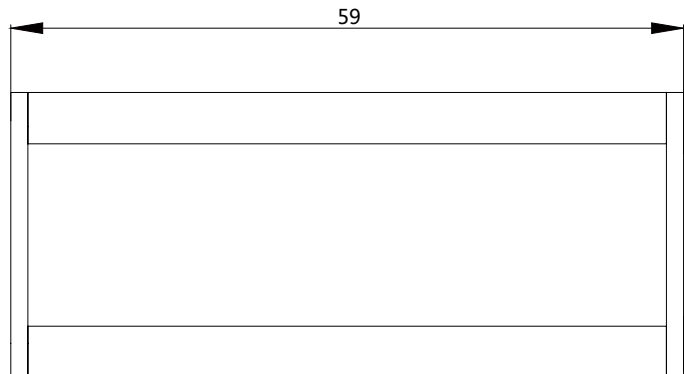
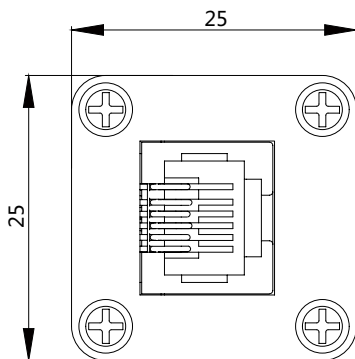



LY21-2

■ Product overview

LY21-2 series signal SPD is connected in front of equipment in series, is mainly used to protect against the overvoltage intruded along with the network lines such as network switch, server, MODEM, network termination equipment and so on. POE network SPD is applicable for power over Ethernet equipment such as POE camera.

■ Features

1. Large tolerance to through-current, it adopts multi-level protection.
2. Built-in fast semiconductor protection devices, fast response, low stray capacitance and low residual voltage.
3. Low insertion loss.
4. POE network lightning protective device uses the network cable to supply power to the equipment, which is security and cost saving.

■ Specifications

Model		LY21-2
Spec		POE
Max continuous operating voltage	Power part	60VDC
Rated load current		500mA
Nominal flow rate		2.5KA
Max flow rate		5KA
Voltage protection level		120V
Rated operating voltage		5V
Max continuous operating voltage		6V
Rated load current		500mA
Flow withstand capacity	Network part	5KV&2.5KA
Clamping voltage x-x (1.2/50)		30V
Transmission rate		100Mbps
Insertion loss		≤0.2dB
Interface type		RJ45
Protection grade		IP20

■ Outline dimensions

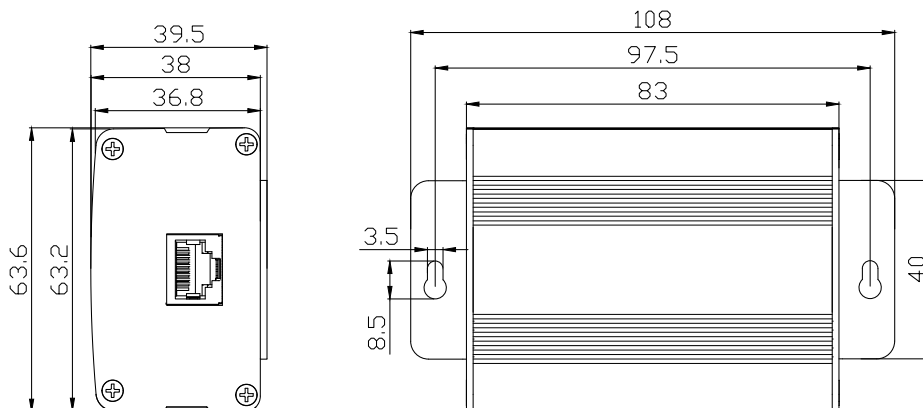

LY21-2

RJ45 network surge protective device



CAT16

LY21-2



CAT24

LY21-2

■ Product overview

LY21-2 series signal SPD is connected in front of equipment in series, is mainly used to protect against the overvoltage intruded along with the network lines such as network switch, server, MODEM, network termination equipment and so on. POE network SPD is applicable for power over Ethernet equipment such as POE camera.

■ Features

1. Large tolerance to through-current, it adopts multi-level protection.
2. Built-in fast semiconductor protection devices, fast response, low stray capacitance and low residual voltage.
3. Low insertion loss.
4. POE network lightning protective device uses the network cable to supply power to the equipment, which is security and cost saving.

■ Specifications

Model	LY21-2
Spec	CAT16/CAT24
Rated operating voltage	5V
Max continuous operating voltage	6V
Rated load current	500mA
Flow withstand capacity	5KV&2.5KA
Clamping voltage $x \times (1.2/50)$	30V
Transmission rate	100Mbps
Insertion loss	≤ 0.2 dB
Interface type	RJ45
Protection grade	IP20

■ Outline dimensions

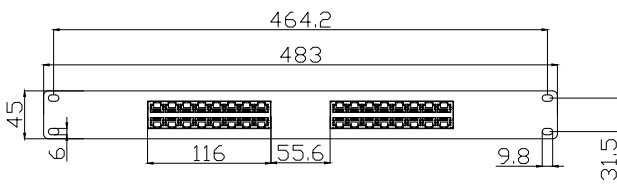

16-port

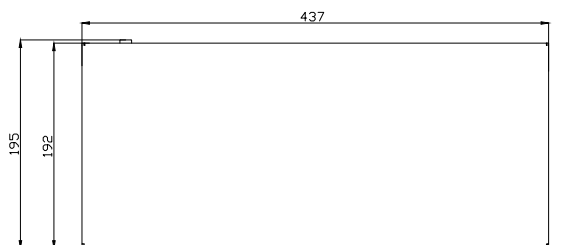
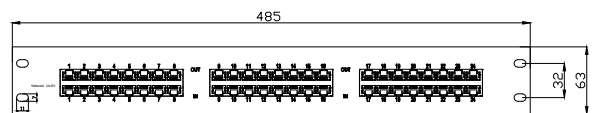

24-port

LY21-2

RJ45 network surge protective device

■ Product overview

LY21-2 series signal SPD is connected in front of equipment in series, is mainly used to protect against the overvoltage intruded along with the network lines such as network switch, server, MODEM, network termination equipment and so on. POE network SPD is applicable for power over Ethernet equipment such as POE camera.



CAT1



CAT4



CAT8

■ Features

1. Large tolerance to through-current, it adopts multi-level protection.
2. Built-in fast semiconductor protection devices, fast response, low stray capacitance and low residual voltage.
3. Low insertion loss.
4. POE network lightning protective device uses the network cable to supply power to the equipment, which is security and cost saving.

■ Specifications

Model	LY21-2
Spec	CAT1/CAT4/CAT8
Rated operating voltage	5V
Max continuous operating voltage	6V
Rated load current	500mA
Flow withstand capacity	5KV&2.5KA
Clamping voltage x-x(1.2/50)	30V
Transmission rate	100Mbps
Insertion loss	≤0.2dB
Interface type	RJ45
Protection grade	IP20

■ Outline dimensions

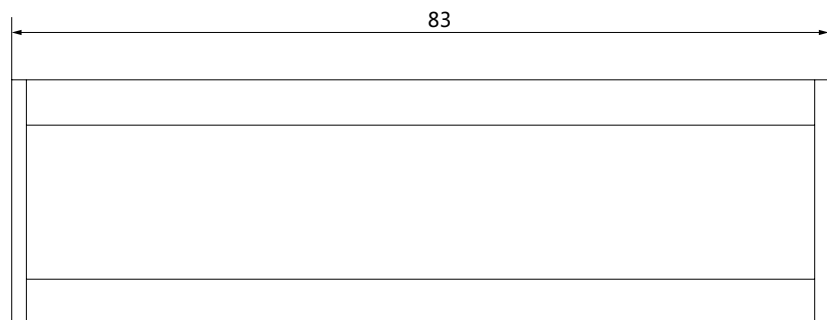
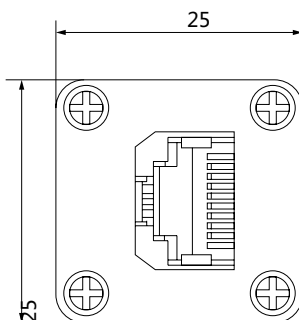

CAT1

LY23

BNC video surge protective device



LY23

■ Product overview

LY23 series SPD is mainly used to protect against the overvoltage intruded along with the video lines such as camera, video monitor, optical transmitter and receiver, display,cable television, homes using television,video matrix, hard disk video, etc.

■ Features

- 1.Large tolerance to through-current, it adopts multi-level protection.
- 2.Fast response and low clamping voltage.
- 3.Low insertion loss.

■ Specifications

Model	LY23
Rated operating voltage	5V
Max continuous operating voltage	6V
Rated load current	500mA
Flow withstand capacity	10KV&5KA
Clamping voltage $x \rightarrow (1.2/50)$	30V
Transmission rate	10Mbps
Insertion loss	$\leq 0.2\text{dB}$
Interface type	BNS
Protection grade	

■ Outline dimensions

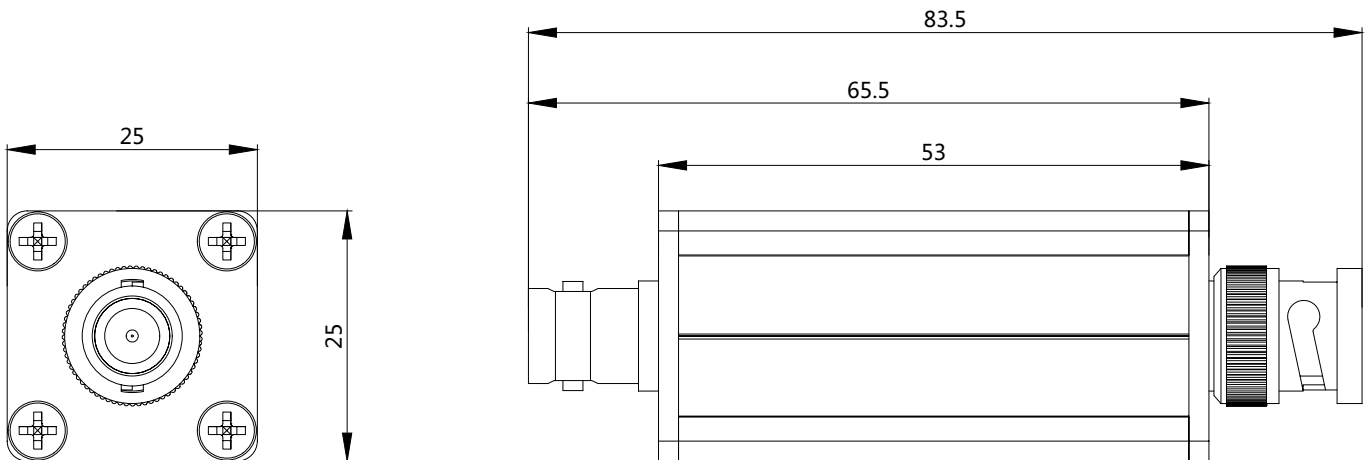

LY23

BNC video surge protective device

■ Product overview

LY23 series SPD is mainly used to protect against the overvoltage intruded along with the video lines such as camera, video monitor, optical transmitter and receiver, display, cable television, homes using television, video matrix, hard disk video, etc.

■ Features

1. Large tolerance to through-current, it adopts multi-level protection.
2. Fast response and low clamping voltage.
3. Low insertion loss.

■ Specifications

Model	LY23	
Spec	4 ports	8 ports
Rated operating voltage	5V	
Max continuous operating voltage	6V	
Rated load current	500mA	
Flow withstand capacity	10KV&5KA	
Clamping voltage $x-(1.2/50)$	30V	
Transmission frequency	10Mbps	
Insertion loss	≤0.2dB	
Interface type	BNC	
Protection grade	IP20	



LY23



LY23

■ Outline dimensions

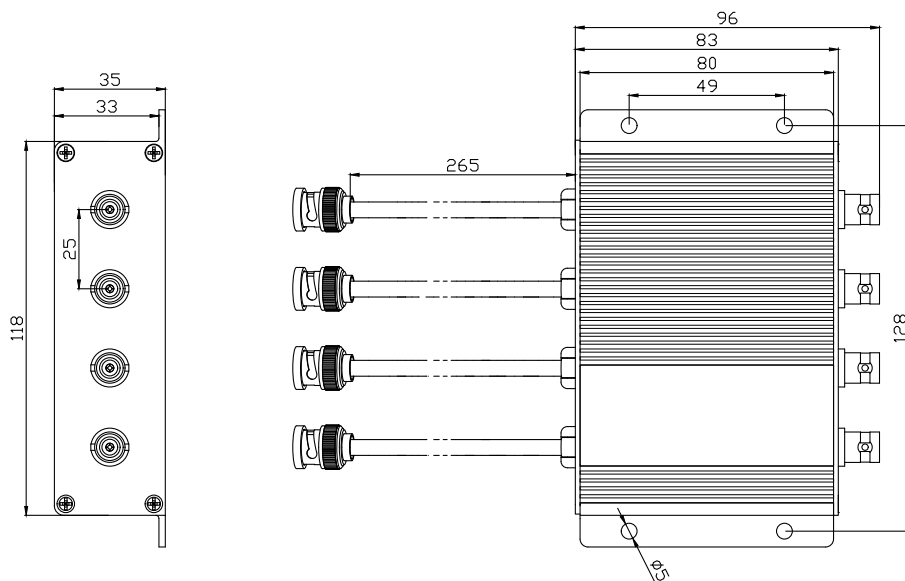

LY23

BNC video surge protective device



Product overview



LY23

LY23 series SPD is mainly used to protect against the overvoltage intruded along with the video lines such as camera, video monitor, optical transmitter and receiver, display, cable television, homes using television, video matrix, hard disk video, etc.

Features

- 1. Large tolerance to through-current, it adopts multi-level protection.
- 2. Fast response and low clamping voltage.
- 3. Low insertion loss.



LY23

Specifications

Model	LY23	
Spec	16 ports	24 ports
Rated operating voltage	5V	
Max continuous operating voltage	6V	
Rated load current	500mA	
Flow withstand capacity	10KV&5KA	
Clamping voltage x-(1.2/50)	30V	
Transmission frequency	10Mbps	
Insertion loss	≤0.2dB	
Interface type	BNC	
Protection grade	IP20	

Outline dimensions

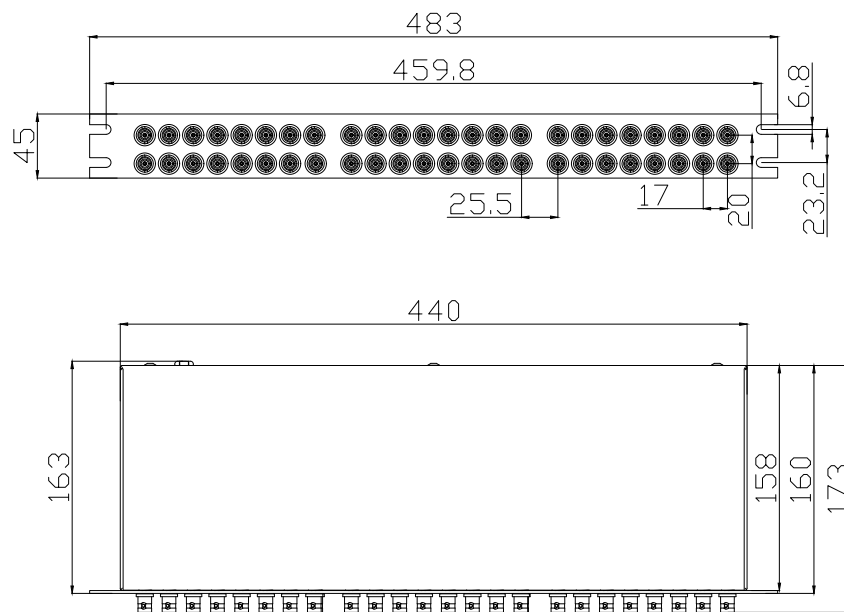



LYX3



LYX2



LYX2



LYX2

■ Product overview

Signal LYX combination series has three-in-one video surveillance lightning protective device, two-in-one video surveillance lightning protective device and power network lightning protective device. Customized special lightning protective device according to the specific characteristics of the surveillance camera is connected in series to the front of the protected equipment; it is suitable for overvoltage protection of power, PTZ control, analog video, network video lines of indoor and outdoor monitoring system camera for city monitoring, communication places, buildings and other security places.

■ Features

1. The product uses series structure design and multi-level protection.
2. It uses terminals with large gap to ensure that product will not be damaged caused by electrical clearance and creepage distance.
3. Large current capacity, fast response, low loss.
4. Indicators at power part indicate work state of the lightning protective device.
5. Integrated combination of the product has features of small size, easy wiring and easy installation.

■ Specifications

Model				
Rated operating voltage		12VAC	24VAC	220VAC
Max continuous operating voltage		15VAC	30VAC	320VAC
Nominal flow rate	Power part	5KA		
Max flow rate		10KA		
Voltage protection level		200V	300V	1100V
Interface type		Connection terminal		
Rated operating voltage		12V		
Max continuous operating voltage		15V		
Rated load current		500mA		
Flow withstand capacity	Control part	10KV&5KA		
Clamping voltage x-x (1.2/50)		60V		
Transmission rate		100Mbps		
Insertion loss		≤0.2dB		
Interface type		Connection terminal		

■ Outline dimensions

LYX2

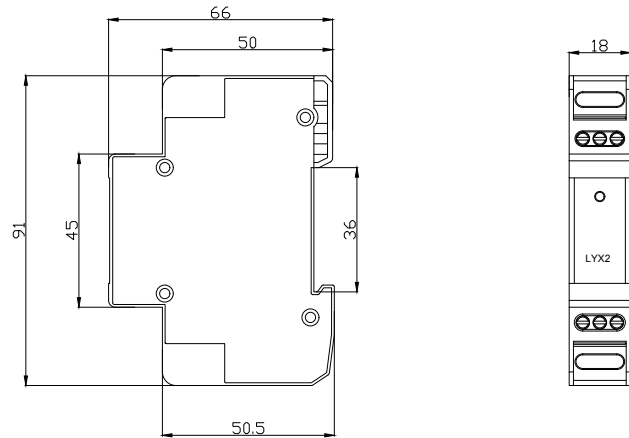

LYX2-S

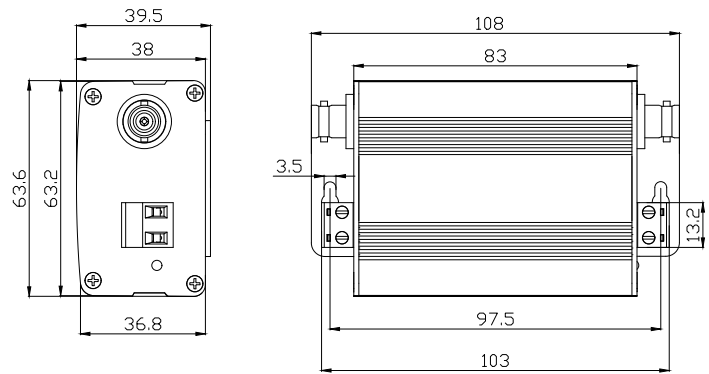

LYX2-W

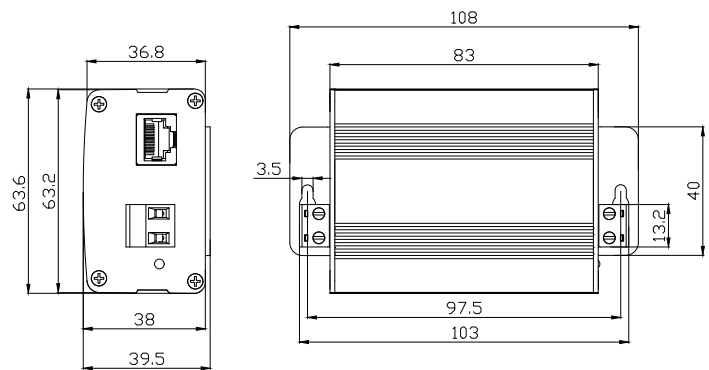

LYX3

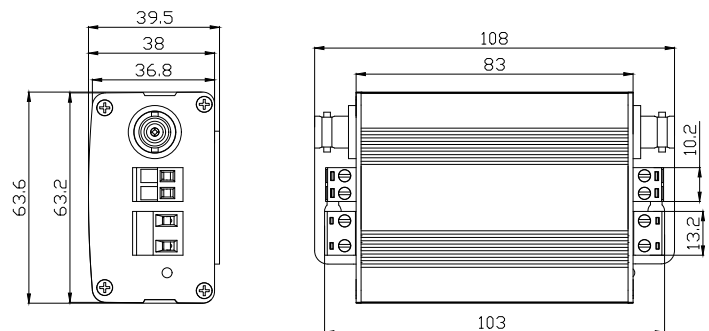



■ Product overview

The waterproof explosion-proof product is suitable for lightning and surge overvoltage protection of 485 data transmission control lines, data communications lines and on-site control signal lines.

■ Features

- 1.The product uses imported semiconductor clamping components through strict quality control, it has stable performance, has multi-level protection and reasonable match between levels.
- 2.Fast response to overvoltage (action time is less than 1ns).
- 3.Accurate clamping, low output residual voltage, small insertion loss, dual overcurrent protection function, reasonable match between levels, all these greatly ensures the safety of protected equipment.
- 4.Waterproof and explosion-proof data signal SPD is pioneering technology in China; it can be applied to overvoltage protection for outdoor and explosion-proof signal lines.
- 5.The product is typically used in overvoltage protection for data control, field control, data communications and other signal lines in workshops of chemical plants, gas station tanker, gas storage, oil depots, chemical warehouses and other inflammable and explosive occasions.
- 6.The product also applies to overvoltage protection for signal lines of security, information technology and other systems in outdoors where requests waterproof and moisture proof.

■ Applications and installation location

This series of product is installed at the interface of data line equipment from LPZ1 area to LPZ3 area.

It applies to overvoltage protection for outdoor security equipment (such as monitoring, cordon prevention, intelligent firefighting, etc.) it does not need to install waterproof device.

It applies to overvoltage protection for signal lines of automatic control equipment in flammable and explosive places such as oil depots, gas storage, gas stations, chemical plants, warehouses and other places , it should be sealed connection to the original explosion-proof device. All wiring must be strongly protected and reliably connected; lightning protection and grounding should comply with lightning protection requirements and the ground wire should be as short and straight as possible.

■ Specifications

Model	LY26-XF					
Rated operating voltage Un (V)	5V	12V	24V	48V	110V	220V
Max continuous voltage Uc (V)	6V	15V	30V	50V	230V	420V
Nominal discharge current (8/20μs)	5kA					
Response time	≤1ns					
Insertion loss	≤0.3dB304					
Shell material	Waterproof and explosion-proof shell					
Protection circuit	Single-channel 1 and 2, double-channel 1,2, 3 and 4					

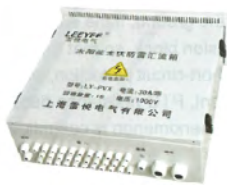

Product overview

In solar photovoltaic power generation system, DC combiner device should be added between PV module and inverter in order to reduce the connection between PV module and inverter, to facilitate maintenance and to improve reliability for large-scale photovoltaic grid-connected power generation system.

The user can combine a certain number of PV modules with the same specifications in series into a PV modules string within the DC voltage range inputted by the inverter, and then connect a number of strings into the photovoltaic combiner box for convergence, then output to the inverter through lightning protective device and circuit breaker, which simplify the system wiring and improve the security of the system.

Features

1. Meet the requirements of outdoor installation;
2. 16 channels of solar battery can be connected at the same time, current of each channel can be up to 10A;
3. Equipped with a high-voltage lightning protective device especially for PV power, both the positive and negative have lightning protection function;
4. Four-pole circuit breaker which positive and negative are connected in series separately can increase DC voltage to not less than DC1000V.

Specifications

Model	LY-PVX							
spec	4	6	8	10	12	16	18	20
PV array input voltage range (V)	DC24-1000							
PV array input channel number	4-channel	6-channel	8-channel	10-channel	12-channel	16-channel	18-channel	20-channel
Max current of each channel (A)	10							
Spec. of output terminal (max)	SAK-10N	SAK-16N	SAK-25N	SAK-25N	SAK-35N	SAK-50N	SAK-75N	SAK-75N

Outline dimensions

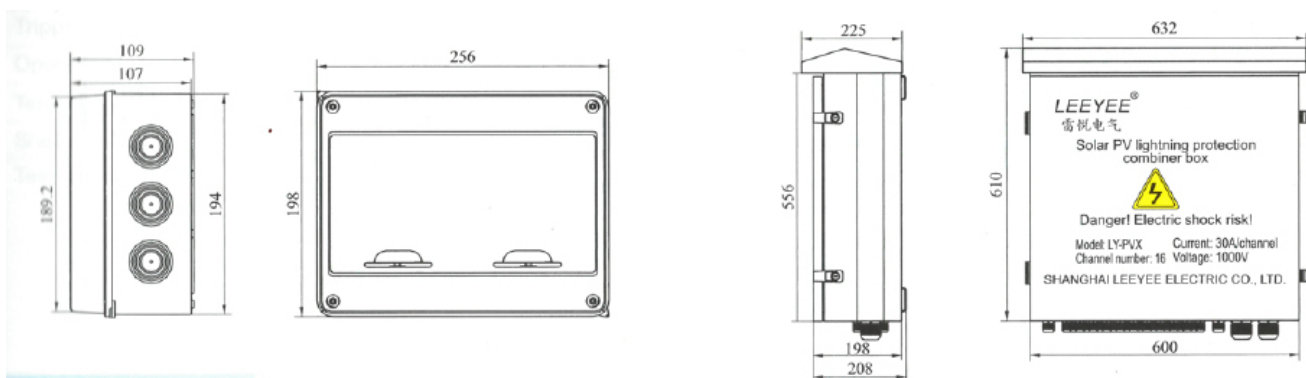

LY30-Z Lightning rod

■ Product overview

Advantages:

Non-electronic type, long life.

The quality of protection will not change after lightning strikes.

Model with different protection radius for selection.

Fully active triggered lightning system.

When there is lightning, self-activation will be acted.

Elegant appearance.

No need maintenance.

LY30Z series of pre-discharge lightning rod uses high-quality steel materials; each model has different characteristics corresponding to different protection range.



LY30-Z-3.1



LY30-Z-3.3



LY30-Z-4.3



LY30-Z-5.3



LY30-Z-6.3

■ Scope of application

Petrochemical warehouse, gasoline station, architecture building, beacon station, communication base station, meteorological station, military base, radar machine room, bank building, etc.

■ Product structure

1. Central collection rod
2. Reflector
3. Trigger device
4. Actuator
5. Fixed plate for actuator

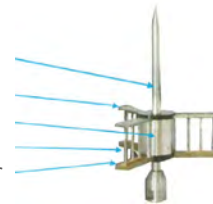

There is a round hole on the reflector corresponding to each actuator, and the reflector is electrically connected to the central collection rod and the ground, and the base of actuator is made of synthetic resin and it is suitable for any corrosive environment.

■ Installation of lightning rod

Installation of LY30-Z lightning rod must strictly follow mandatory provisions in "Building Lightning Protection Design Code"(GB50057-2010) of Lightning Protection Standards of the People's Republic of China.

LY30-Z

Lightning rod



■ Height and protection radius (m)

Cat	Protection height Cat. I D-20M	Protection radius (m)	Protection height Cat. II D-50M	Protection radius (m)	Protection height Cat. III D-60M	Protection radius (m)
Height of the tip of LY-30-Z-300 lightning rod to the ground Contrast list of protection radius (m)	5	42	42	57	5	64
	6	42	42	58	8	67
	7	43	43	59	10	68
	8	43	43	60	15	72
	10	43	43	63	20	75
	15	44	44	65	45	83
	20	45	45	70	60	85

Note: The above data is the test result when the height of the lightning rod H = 5 meters.

Calculation method of the protection radius of the active pre-discharge lightning rod

Suppose that the forestall start time of the lightning rod is T, then the forestall distance of upward leader $\Delta L = V \cdot \Delta T$ according to the calculation method provided by NFC-17-102 standard, the protection radius Rp is calculated according to the following formula:

Representative= $h(2D-h) + \Delta L(2d + \Delta L)h \geq 5$

D motor distance, it depends on the level of protected buildings, for level III protection object, D values are 20m, 45m, 60m separately.

h is the distance from the top of the lightning rod to the protected plane.

ΔT is tested by the evaluation and calculated (see table above) $V = 106\text{m/s}$, $\Delta L = V \cdot \Delta T$

■ Main technical parameters

Installation height of LY30-Z lightning rod	5	6	7	8	10	15	20	45	60
LY30-Z protection Cat. I									
LY30-Z-3.1 lightning rod	22	22	23	23	25	25	25	-	-
LY30-Z-3.3 lightning rod	42	42	43	43	43	44	45	-	-
LY30-Z-4.3 lightning rod	51	51	52	52	53	53	54	-	-
LY30-Z-5.3 lightning rod	61	61	61	61	62	62	63	-	-
LY30-Z-6.3 lightning rod	70	70	70	70	71	71	72	-	-
LY30-Z protection Cat. II									
LY30-Z-3.1 lightning rod	44	44	46	47	48	51	59	-	-
LY30-Z-3.3 lightning rod	57	58	59	60	63	65	70	-	-
LY30-Z-4.3 lightning rod	68	69	69	70	73	74	79	-	-
LY30-Z-5.3 lightning rod	78	79	79	80	82	84	88	-	-
LY30-Z-6.3 lightning rod	88	89	89	90	92	93	97	-	-
LY30-Z protection Cat. III									
LY30-Z-3.1 lightning rod	50	50	52	52	55	59	74	-	-
LY30-Z-3.3 lightning rod	64	67	68	72	75	83	85	-	-
LY30-Z-4.3 lightning rod	76	78	79	82	85	92	94	-	-
LY30-Z-5.3 lightning rod	87	88	90	92	94	101	103	-	-
LY30-Z-6.3 lightning rod	97	99	100	102	104	110	112	-	-

LY-J, 3M Lightning counter



Inductive lightning counter

■ Main technical parameters

Model	Operating voltage	Action current	Counting times	Sampling mode
LY-J inductive lightningcounter	220VAC	1KA-150KA (8/20us)	0-99 times	Mutual inductance sampling

Model	LY-3M direct lightning counter
Sensitivity of counter	≥3KA above lightning current
Recording times	1×10 ⁵ times
Shell dim	150×70×40
Installation method	Stainless steel anchor ear of Φ90, installed with stainless steel bolts directly

■ Features

- 1.Accurate technology
- 2.Strong anti-interference capacity
- 3.Save data for 1 month after power failure
- 4.Easy use and installation, can be used with various surge protective devices and equipment

■ Application

LY-3M direct lightning counter is a passive counter that can be installed on the lower lead wire (or bar) of lightning rod, and records the lightning current of 3KA above directly. It has functions of rainproof,dustproof and sunlight proof ,with stainless steel shell, it is convenient to install, especially suitable for lightning record for lightning rod.

■ LY-J wiring method

Connect the transformer with ground circuit in series, connect the two binding posts of transformer to lightning counter 5, 6, binding posts should be wired firmly, then push down the display switch to get lightning counting times.

■ Installation and wiring diagram

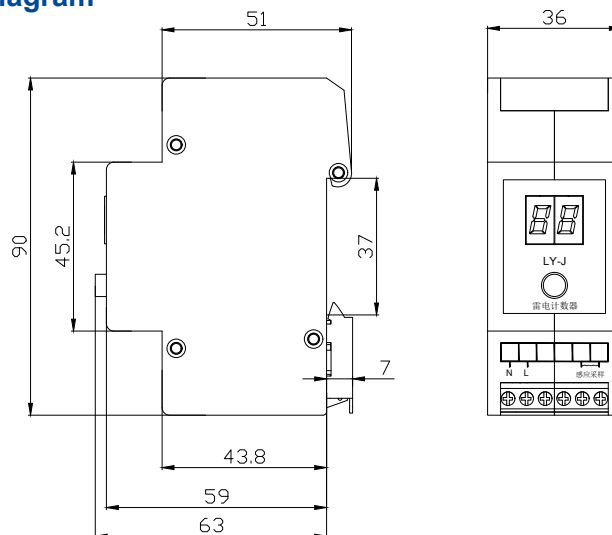

Product overview



Lightning counter is designed to analyze the lightning accident, it almost has no practical significance in the practical application, the most important problem is that it cannot record the actual time of lightning strike, intelligent lightning counter can accurately and timely transmit the lightning time to the background for saving, it can accurately help customers to analyze the lightning accidents.

Features

1. DIN rail installation, it is easy for installation and use together with lightning protection module
2. 220V power supply
3. Standard modbus protocol
4. It can be connected to the background server, the computer can remotely monitor any one of the collection terminals in the network.

Specifications

Model	LY-ZJ
Power grid system	220/380 power supply
The number of lightning stroke	0-99 times of circulation, the background will record the time of lightning stroke
Communication mode	RS485, wireless
Protocol	Modbus
Input voltage	220V
Operating temperature	-20°C ~+60°C
Dimension	90×36×66mm

Installation and wiring diagram

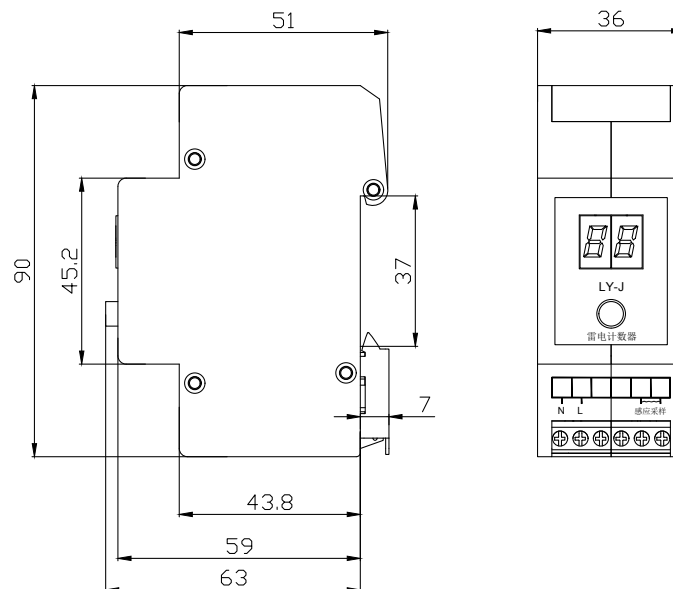

LY-ZFC Intelligent lightning detection module



■ Product overview

Intelligent lightning protection and monitoring module contains monitoring of switching value, the number of lightning, open state and ambient temperature. One way of switching value monitors whether the lightning protection module is degraded; the number of lightning is displayed in nixie tube, and at the same time, the number of lightning can be transmitted to the background through 485; air switch state monitors the voltage between live wire and zero line at the output end, if it is 220V, then it judged that the air switch is normal, if it is 0 then the air switch is open. (4P.air switch should be integrated); ambient temperature monitoring can be set with alarm value when the temperature of SPD reached to a certain value.

■ Features

1. Module type, DIN rail installation, it is easy for installation and use together with lightning protection module
2. 220V power supply
3. Standard modbus protocol
4. It can be connected to the background server, the computer can remotely monitor any one of the collection terminals in the network.

■ Specifications

Model	LY-ZFC
Power grid system	220/380 power supply
The number of lightning stroke	0-99 times circulation, the background will record the time of lightning stroke
SPD remote signaling monitoring	1-channel
Temperature monitoring	1-channel
Air switch status monitoring	1-channel
Communication mode	Rs485 □ wireless
Protocol	Modbus
Input voltage	220V
Operating temperature	-20°C ~+60°C
Dimension	90×36 ×66mm

■ Outline dimensions

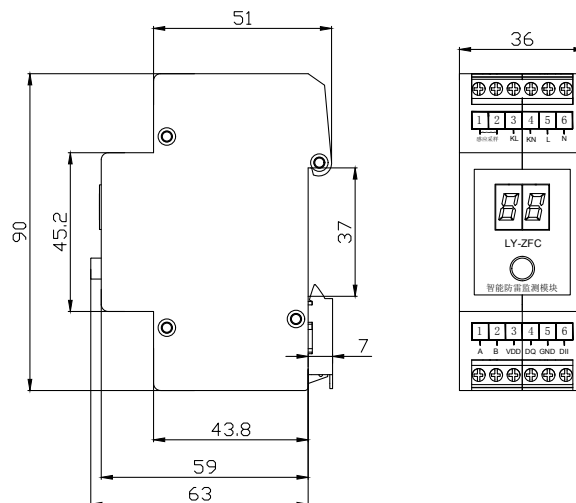



■ Product overview

LY type varistor has advantages of large discharge current capacity, wide voltage range, quick response, strong surge suppression, easy installation and replacement and so on. It is widely used in switching overvoltage protection and atmospheric overvoltage protection for railway automatic signal, traffic control center, communication relay station, low-voltage distribution, semiconductor device and all kinds of electric apparatuses.

■ Features

1. Wide voltage range 47V-1200V
2. High nonlinear coefficient
3. Large discharge current capacity



■ Main applications

1. Protection of semiconductor devices
2. Household electric surge and overvoltage protection
3. Surge protection of communication, measurement and control instruments
4. Switching overvoltage protection of solenoid valves and relays

■ Model and connotation

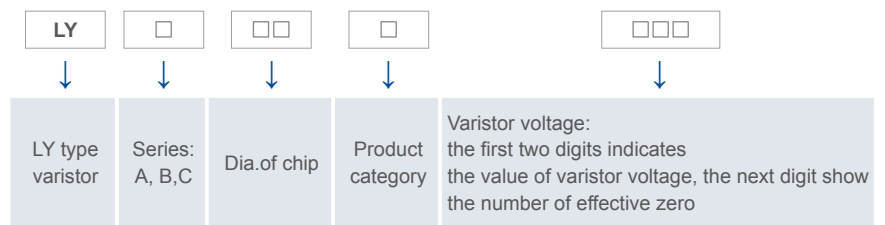

■ Specifications

Model	Varistor voltage V(V)	Max allowable loop voltage		Max clamping voltage $V_{150A}(V)$	Energy tolerance (J)	Max peak current		Capacitance (reference value) pF
		Acrms	DC			1time (A)	2time (A)	
LYA25D341	430(387-473)	275	350	710	220	15000	10000	1250
LYA25D471	470(423-517)	300	385	775	250	15000	10000	1100
LYA25D511	510(459-561)	320	415	845	270	15000	10000	1000
LYA25D561	560(504-616)	350	455	925	270	15000	10000	950
LYA25D621	620(538-682)	385	505	1025	270	15000	10000	900
LYA25D681	680(612-748)	420	560	1120	270	15000	10000	850
LYA25D751	750(675-825)	460	615	1240	300	15000	10000	800
LYA25D781	780(702-858)	485	640	1280	300	15000	10000	750
LYA25D821	820(738-902)	510	670	1355	325	15000	10000	720
LYA25D911	910(819-1001)	550	745	1500	360	15000	10000	680
LYA25D102	1000(900-1100)	625	825	1650	400	15000	10000	650
LYA25D112	1100(990-1210)	680	895	1815	440	15000	10000	600

Model	Varistor voltage V(V)	Max allowable loop voltage		Max clamping voltage $V_{150A}(V)$	Energy tolerance (J)	Max peak current		Capacitance (reference value) pF
		Acrms	DC			1time (A)	2time (A)	
LYA25S341	430(387-473)	275	350	710	360	25000	20000	4200
LYA25S471	470(423-517)	300	385	775	360	25000	20000	3800
LYA25S511	510(459-561)	320	415	845	390	25000	20000	3500
LYA25S561	560(504-616)	350	455	925	390	25000	20000	3150
LYA25S621	620(538-682)	385	505	1025	390	25000	20000	2800
LYA25S681	680(612-748)	420	560	1120	400	25000	20000	2500
LYA25S751	750(675-825)	460	615	1240	440	25000	20000	2100
LYA25S781	780(702-858)	485	640	1280	440	25000	20000	1800
LYA25S821	820(738-902)	510	670	1355	500	25000	20000	1500
LYA25S911	910(819-1001)	550	745	1500	550	25000	20000	1100
LYA25S102	1000(900-1100)	625	825	1650	600	25000	20000	900
LYA25S112	1100(990-1210)	680	895	1815	650	25000	20000	850

