

# LM2596 Buck Converter Module

## FEATURES

- LM2596 DC-DC Buck Converter Step Down Module
- Input voltage range: DC 4V to 35V (Input voltage must be higher than the voltage output to 1.5V or more cannot be boosted.)
- Output voltage range: 1.25V to 30V DC voltage is continuously adjustable, high efficiency and maximum output current of 3A.
- Output current: Rated current 2A, maximum 3A. (Heat sink required.)
- Switching Frequency: 150kHz
- All solid capacitors and High-Q inductors.

## APPLICATIONS

- Simple high efficiency step-down regulator
- On-card switching regulator
- Efficient Pre-Regulator for Linear Regulators

## DESCRIPTION

The LM2596 Buck Converter Module is a non-isolated step-down DC-DC converter with non-synchronous rectification.

## APPLICATION GUIDE

The power dissipation of the LM2596 Buck Converter Module is internally limited. Small sized PCB and thermal resistance of IC package have limited the power dissipation of the module.

Depending on the conversion condition, 3A full loading is not might possible due to the internally limited power dissipation.



## ORDERING INFORMATION

Part Number	MBC2596-01
Device	LM2596 Buck Converter Module
Package	Assembled Module

# LM2596 Buck Converter Module

## PARTS LIST & LAYOUT

Name	Description	P/N	Qty.	Distributor
PCB	Printed Circuit Board	Lead-Free PCB	1	TAEJIN
IC	LM2596-ADJ, TO-263-5L	LM2596R-ADJ, LM2596GR-ADJ	1	TAEJIN
Diode	Schottky Diode	SS34, 1N5822, DO-214AC	1	Generic
Capacitor	100 $\mu$ F Capacitor	100 $\mu$ F/50V Electrolytic Capacitor	1	Generic
Capacitor	220 $\mu$ F Capacitor	220 $\mu$ F/35V Electrolytic Capacitor	1	Generic
Inductor	47 $\mu$ H Inductor	3A	1	Generic
Resistor	1K $\Omega$ Resistor	1.0K $\Omega$ 5% Resistor	1	Generic
Resistor	330 $\Omega$ Resistor	330 $\Omega$ 5% Resistor	1	Generic
LED	LED for Power Indicator	3mm LED, Red	1	Generic
Capacitor	10nF Capacitor	10nF/25V Ceramic Capacitor	1	Generic
Capacitor	1 $\mu$ F Capacitor	1 $\mu$ F/16V Ceramic Capacitor	1	Generic

## SCHEMATICS

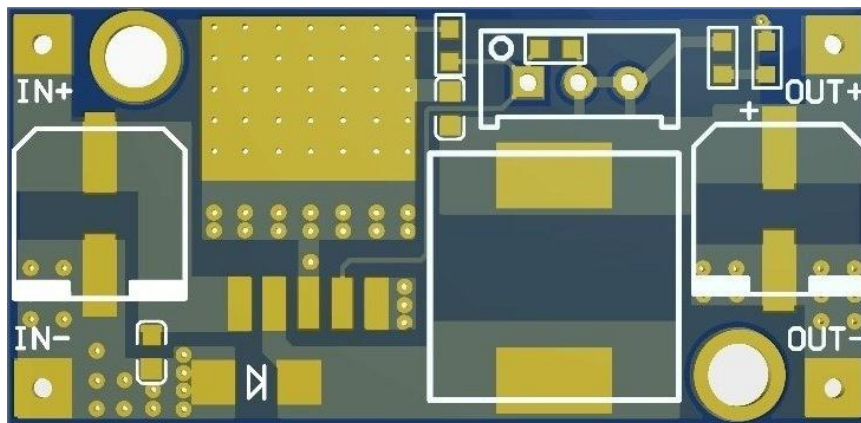

# LM2596 Buck Converter Module

---

## LAYOUT



## I/O PORT CONFIGURATION AND DESCRIPTION

Designator	Port Name	Port Description
IN+	Input Positive	Power In.
IN-	Input Negative	Ground for Power In. Connect GND for normal use.
OUT+	Output Positive	Power Out.
OUT-	Output Negative	Ground for Power Out. Connect GND for normal use.

# LM2596 Buck Converter Module

---

## REVISION NOTICE

The description in this datasheet is subject to change without any notice to describe its electrical characteristics properly.

## FEATURES

- 3.3V, 5.0V, 12V, and Adjustable Output version
- Adjustable Output Voltage range, 1.2V to 37V  
±4% Max. Over Line and Load conditions
- Guaranteed Output Current of 3A
- Available in TO-263, TO-220 Packages
- Requires Only 4 External Components
- Excellent Line and Load Regulation Specifications
- 150kHz Fixed Frequency Internal Oscillator
- TTL Shutdown Capability
- Low Power Standby Mode, IQ typically 100mA
- Thermal Shutdown and Current Limit Protection
- Moisture Sensitivity Level 3

## APPLICATION

- Simple High-Efficiency Step-Down(Buck) Regulator
- Efficient Pre-Regulator for Linear Regulators
- On-Card Switching Regulators
- Positive to Negative Converter(Buck-Boost)
- Negative Step-Up Converters
- Power Supply for Battery Chargers

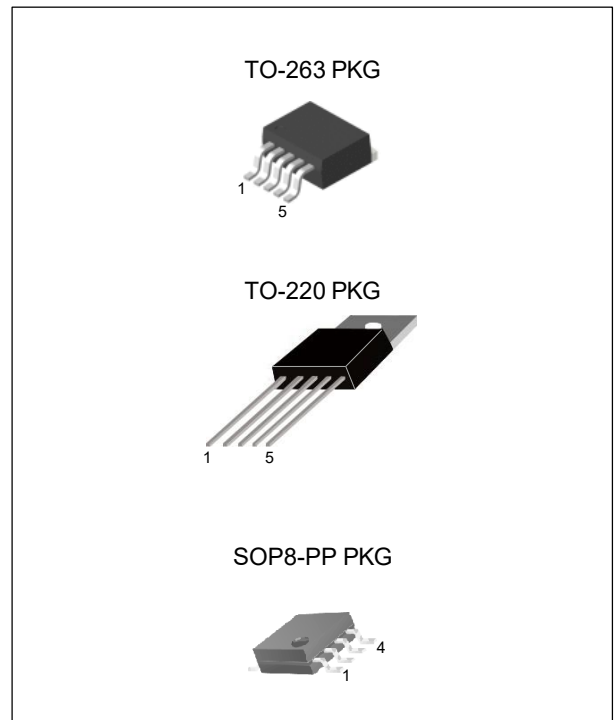

## ORDERING INFORMATION

Device	Package
LM2596R-X.X	TO-263-5L
LM2596T-X.X	TO-220-5L
LM2596DP-X.X	SOP-8PP

X.X = Output Voltage = 3.3, 5.0, 12, ADJ

## DESCRIPTION

The LM2596 series of regulators are monolithic integrated circuits ideally suited for easy and convenient design of a step-down switching regulator (buck converter). All circuits of this series are capable of driving a 3.0A load with excellent line and load regulation. These devices are available in fixed output voltages of 3.3V, 5.0V, 12V, and an adjustable output version. These regulators were designed to minimize the number of external components to simplify the power supply design. Standard series of inductors optimized for use with the LM2596 are offered by several different inductor manufacturers. Since the LM2596 converter is a switch-mode power supply, its efficiency is significantly higher in comparison with popular three-terminal linear regulators, especially with higher input voltages. In many cases, the power dissipated is so low that no heatsink is required or its size could be reduced dramatically. A standard series of inductors optimized for use with the LM2596 are available from several different manufacturers. This feature greatly simplifies the design of switch-mode power supplies. The LM2596 features include a guaranteed +/- 4% tolerance on output voltage within specified input voltages and output load conditions, and +/-15% on the oscillator frequency (+/- 2% over 0°C to 125°C). External shutdown is included, featuring 80µA (typical) standby current. Self-protection features include a two stage frequency reducing current limit for output switch and an over temperature shutdown for complete protection under fault conditions.

## 3.0A, 150kHz, Step-Down Switching Regulator

LM2596

### Ordering Information

V <sub>OUT</sub>	Package	Order No.	Description	Package Marking	Status
ADJ	SOP-8PP	LM2596DP-ADJ	3A, Adjustable, 150kHz, On/off	LM2596-ADJ	Active
	TO-220-5L	LM2596T-ADJ	3A, Adjustable, 150kHz, On/off	LM2596-ADJ	Active
	TO-263-5L	LM2596R-ADJ	3A, Adjustable, 150kHz, On/off	LM2596-ADJ	Active
3.3V	SOP-8PP	LM2596DP-3.3	3A, Fixed, 150kHz, On/off	LM2596-3.3	Active
	TO-220-5L	LM2596T-3.3	3A, Fixed, 150kHz, On/off	LM2596-3.3	Active
	TO-263-5L	LM2596R-3.3	3A, Fixed, 150kHz, On/off	LM2596-3.3	Active
5.0V	SOP-8PP	LM2596DP-5.0	3A, Fixed, 150kHz, On/off	LM2596-5.0	Active
	TO-220-5L	LM2596T-5.0	3A, Fixed, 150kHz, On/off	LM2596-5.0	Active
	TO-263-5L	LM2596R-5.0	3A, Fixed, 150kHz, On/off	LM2596-5.0	Active
12V	SOP-8PP	LM2596DP-12	3A, Fixed, 150kHz, On/off	LM2596-12	Contact Us
	TO-220-5L	LM2596T-12	3A, Fixed, 150kHz, On/off	LM2596-12	Active
	TO-263-5L	LM2596R-12	3A, Fixed, 150kHz, On/off	LM2596-12	Active

## PIN CONFIGURATION

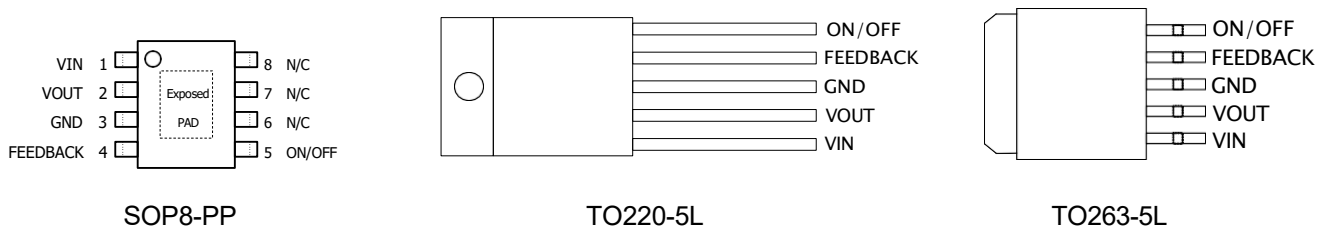

## PIN DESCRIPTION

Package		Symbol	Description
TO-220 5L	SOP8-PP		
TO-263 5L			
1	1	VIN	This pin is the positive input supply for the LM2596 step-down switching regulator. In order to minimize voltage transients and to supply the switching currents needed by the regulator, a suitable input bypass capacitor must be present.
2	2	VOUT	This is the emitter of the internal switch. The saturation voltage $V_{sat}$ of this output switch is typically 1.5 V. It should be kept in mind that the PCB area connected to this pin should be kept to a minimum in order to minimize coupling to sensitive circuitry.
3	3	GND	Circuit ground pin.
4	4	FEEDBACK	This pin senses regulated output voltage to complete the feedback loop. The signal is divided by the internal resistor divider network R2, R1 and applied to the non-inverting input of the internal error amplifier. In the Adjustable version of the LM2596 switching regulator this pin is the direct input of the error amplifier and the resistor network R2, R1 is connected externally to allow programming of the output voltage.
5	5	ON/OFF	It allows the switching regulator circuit to be shut down using logic level signals, thus dropping the total input supply current to approximately 80uA. The threshold voltage is typically 1.3V. Applying a voltage above this value (up to +Vin) shuts the regulator off. If the voltage applied to this pin is lower than 1.3V or if this pin is left open, the regulator will be in the "on" condition.
-	6, 7, 8	N.C.	No Connect.

\* Exposed Pad of SOP8-PP package should be externally connected to GND.

# 3.0A, 150kHz, Step-Down Switching Regulator

LM2596

## Typical Application (Fixed Output Voltage Versions)

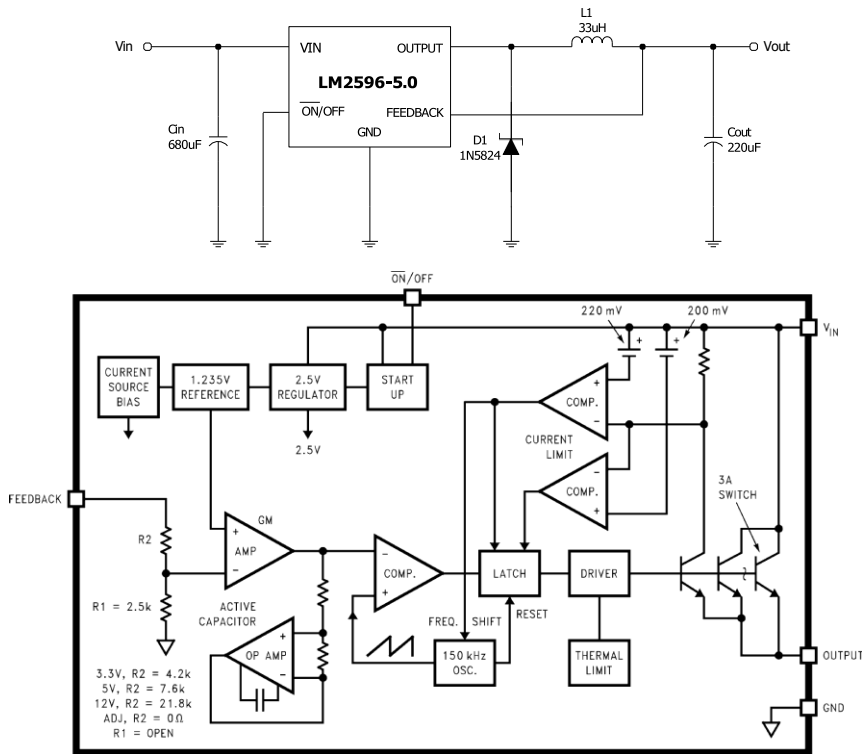

## Absolute Maximum Ratings

Rating	Symbol	Value	UNIT
Maximum Supply Voltage	Vin	45	V
On/Off Pin Input Voltage	-	$-0.3V \leq V \leq +Vin$	V
Output Voltage to Ground (Steady-State)	-	-1.0	V
Power Dissipation			
SOP8-PP-8Lead	$P_D$	Internally Limited	W
Thermal Resistance, Junction to Ambient	$\theta_{JA}$	Contact us	$^{\circ}C/W$
Thermal Resistance, Junction to Case	$\theta_{JC}$	Contact us	$^{\circ}C/W$
TO-220-5Lead	$P_D$	Internally Limited	W
Thermal Resistance, Junction to Ambient	$\theta_{JA}$	65	$^{\circ}C/W$
Thermal Resistance, Junction to Case	$\theta_{JC}$	5	$^{\circ}C/W$
TO-263-5Lead	$P_D$	Internally Limited	W
Thermal Resistance, Junction to Ambient	$\theta_{JA}$	70	$^{\circ}C/W$
Thermal Resistance, Junction to Case	$\theta_{JC}$	5	$^{\circ}C/W$
Storage Temperature Range	$T_{STG}$	-60 to +150	$^{\circ}C$
Minimum ESD Rating (Human Body Model)	-	2	kV
Lead Temperature (Soldering, 10seconds)	-	260	$^{\circ}C$
Maximum Junction Temperature	$T_J$	150	$^{\circ}C$

### 3.0A, 150kHz, Step-Down Switching Regulator

LM2596

**OPERATING RATINGS** (Operating Ratings indicate conditions for which the device is intended to be functional, but do not guarantee specific performance limits. For guaranteed specifications, see the Electrical Characteristics.)

Rating	Symbol	Value.	Unit
Operating Junction Temperature Range	T <sub>J</sub>	-40 to +125	°C
Supply Voltage	V <sub>in</sub>	40	V

### ELECTRICAL CHARACTERISTICS / SYSTEM PARAMETERS ([Note 1] Test Circuit Figure 2)

(Unless otherwise specified, V<sub>in</sub> = 12V for the 3.3V, 5.0V, and Adjustable version, V<sub>in</sub> = 25V for the 12V version. I<sub>LOAD</sub> = 500 mA. For typical values T<sub>J</sub> = 25°C, for min/max values T<sub>J</sub> is the operating junction temperature range that applies [Note 2], unless otherwise noted.)

Characteristics	Symbol	Min	TYP	Max	Unit
<b>LM2596-3.3V ([Note 1] Test Circuit Figure 2)</b>					
Output Voltage (V <sub>in</sub> =12V, I <sub>LOAD</sub> =0.5A, T <sub>J</sub> =25°C)	V <sub>out</sub>	3.234	3.3	3.366	V
Output Voltage (6.0V≤V <sub>in</sub> ≤40V, 0.5A≤I <sub>LOAD</sub> ≤3.0A	V <sub>out</sub>				V
T <sub>J</sub> =25°C		3.168	3.3	3.432	
T <sub>J</sub> =-40°C ~ +125°C		3.135	-	3.465	
Efficiency (V <sub>in</sub> =12V, I <sub>LOAD</sub> =3.0A)	η	-	73	-	%

<b>LM2596-5.0V ([Note 1] Test Circuit Figure 2)</b>					
Output Voltage (V <sub>in</sub> =12V, I <sub>LOAD</sub> =0.5A, T <sub>J</sub> =25°C)	V <sub>out</sub>	4.9	5.0	5.1	V
Output Voltage (8.0V≤V <sub>in</sub> ≤40V, 0.5A≤I <sub>LOAD</sub> ≤3.0A	V <sub>out</sub>				V
T <sub>J</sub> =25°C		4.8	5.0	5.2	
T <sub>J</sub> =-40°C ~ +125°C		4.75	-	5.25	
Efficiency (V <sub>in</sub> =12V, I <sub>LOAD</sub> =3.0A)	η	-	80	-	%

<b>LM2596-12V ([Note 1] Test Circuit Figure 2)</b>					
Output Voltage (V <sub>in</sub> =25V, I <sub>LOAD</sub> =0.5A, T <sub>J</sub> =25°C)	V <sub>out</sub>	11.76	12	12.24	V
Output Voltage (15V≤V <sub>in</sub> ≤40V, 0.5A≤I <sub>LOAD</sub> ≤3.0A	V <sub>out</sub>				V
T <sub>J</sub> =25°C		11.52	12	12.48	
T <sub>J</sub> =-40°C ~ +125°C		11.4	-	12.6	
Efficiency (V <sub>in</sub> =12V, I <sub>LOAD</sub> =3.0A)	η	-	90	-	%

<b>LM2596-ADJ ([Note 1] Test Circuit Figure 2)</b>					
Feedback Voltage (V <sub>in</sub> =12V, I <sub>LOAD</sub> =0.5A, T <sub>J</sub> =25°C)	V <sub>out</sub>	1.217	1.23	1.243	V
Feedback Voltage(8.0V≤V <sub>in</sub> ≤40V, 0.5A≤I <sub>LOAD</sub> ≤3.0A, V <sub>out</sub> =5.0V)	V <sub>out</sub>				V
T <sub>J</sub> =25°C		1.193	1.23	1.267	
T <sub>J</sub> =-40°C ~ +125°C		1.18	-	1.28	
Efficiency (V <sub>in</sub> =12V, I <sub>LOAD</sub> =3.0A, V <sub>out</sub> =5.0V)	η	-	73	-	%

### 3.0A, 150kHz, Step-Down Switching Regulator

LM2596

Characteristics	Symbol	Min	TYP	Max	Unit
<b>All Output Voltage Versions</b>					
Feedback Bias Current (Vout=5.0V [Adjustable Version Only]) T <sub>J</sub> =25°C T <sub>J</sub> = 0 ~ +125°C	I <sub>b</sub>	11.52 11.4	12 -	12.48 12.6	nA
Oscillator Frequency T <sub>J</sub> =25°C T <sub>J</sub> = 0 ~ +125°C	F <sub>osc</sub>	127 110	150 -	173 173	kHz
Saturation Voltage (I <sub>out</sub> =3.0A [note 3]) T <sub>J</sub> =25°C T <sub>J</sub> = 0 ~ +125°C	V <sub>sat</sub>	- -	1.16 -	1.4 1.5	V
Max Duty Cycle ("0") [Note 4]	DC	-	100	-	%
Current Limit (Peak Current [Note 3]) T <sub>J</sub> =25°C T <sub>J</sub> = 0 ~ +125°C	I <sub>CL</sub>	3.6 3.4	4.5 -	6.9 7.5	A
Output Leakage Current [Note 5 and 6], T <sub>J</sub> =25°C Output = 0V Output = -1.0V	I <sub>L</sub>	- -	- 2	25 10	μA mA
Quiescent Current [Note 5] T <sub>J</sub> =25°C T <sub>J</sub> = 0 ~ +125°C	I <sub>Q</sub>	- -	5 -	- 10	mA
Standby Quiescent Current (ON/OFF Pin = 5.0V ("off")) T <sub>J</sub> =25°C T <sub>J</sub> = 0 ~ +125°C	I <sub>STBY</sub>	- -	80 -	200 250	μA
ON/OFF Pin Logic Input Level (Test circuit Figure 2) V <sub>out</sub> =0V T <sub>J</sub> =25°C T <sub>J</sub> = 0 ~ +125°C V <sub>out</sub> =Nominal Output Voltage T <sub>J</sub> =25°C T <sub>J</sub> = 0 ~ +125°C	V <sub>IH</sub>  V <sub>IL</sub>	2.0 2.0 - -	1.3 - 1.3 -	- - 0.6 0.6	V
ON/OFF Pin Input Current (Test Circuit Figure 2) V <sub>LOGIC</sub> = 2.5V (Regulator OFF) V <sub>LOGIC</sub> = 0.5V (Regulator ON)	I <sub>IH</sub> I <sub>IL</sub>	- -	5 0.02	15 5.0	μA

- External components such as the catch diode, inductor, input and output capacitors can affect switching regulator system performance. When the LM2596 is used as shown in the Figure 1 test circuit, system performance will be as shown in system parameters section .
- Tested junction temperature range for the LM2596 : T<sub>LOW</sub> = -40°C T<sub>HIGH</sub> = +125°C
- Output (Pin 2) sourcing current. No diode, inductor or capacitor connected to output pin.
- Feedback (Pin 4) removed from output and connected to 0 V.
- Feedback (Pin 4) removed from output and connected to +12V for the Adjustable, 3.3V, and 5.0V versions, and +25 V for the 12V versions, to force the output transistor "off".C195
- V<sub>in</sub> = 40 V.

## TYPICAL PERFORMANCE CHARACTERISTICS (Circuit of Figure 2)

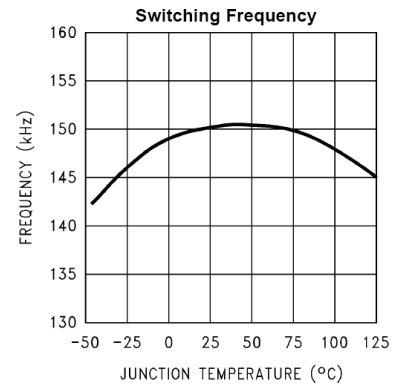
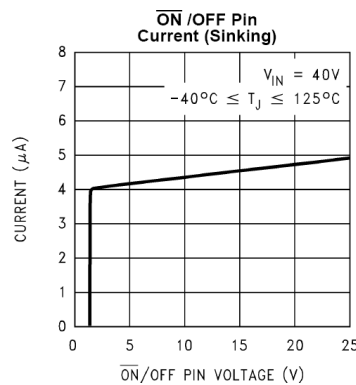
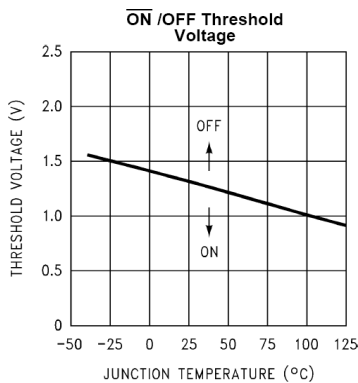
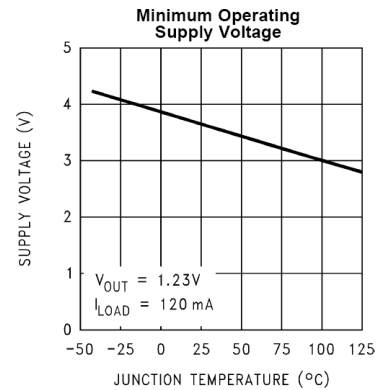
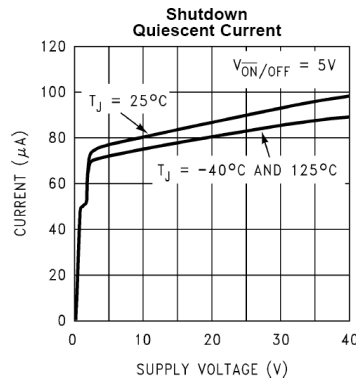
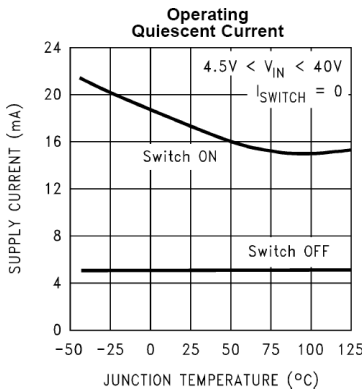
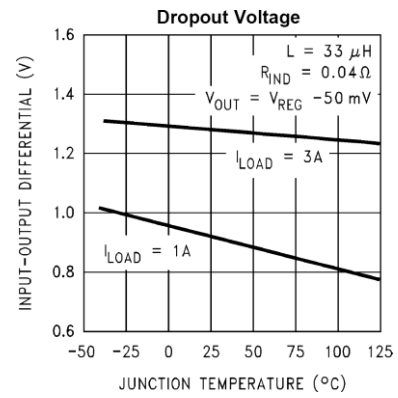
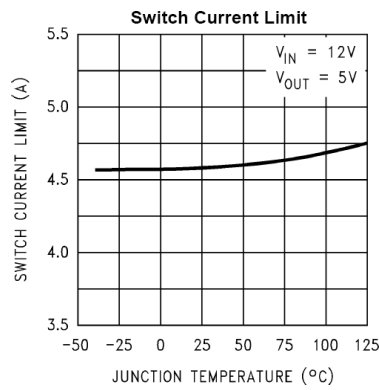
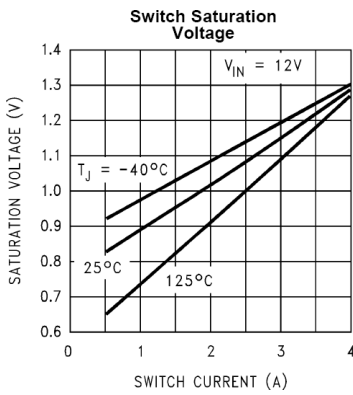
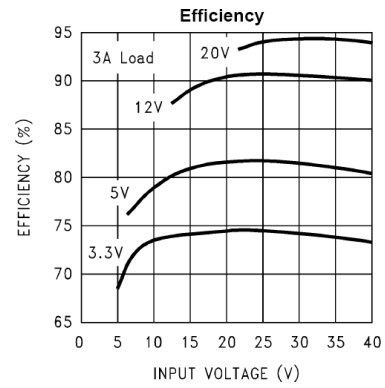
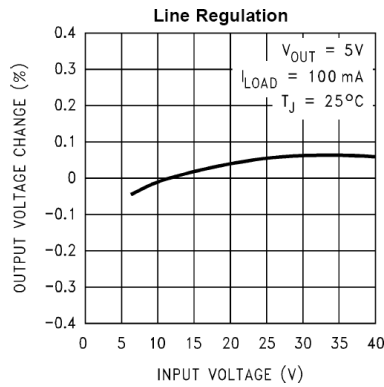
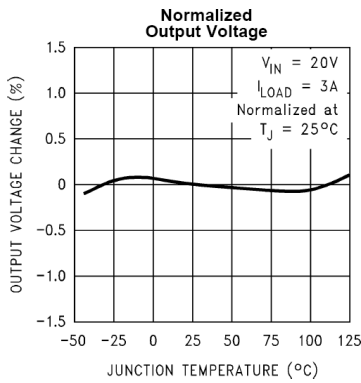

## TYPICAL PERFORMANCE CHARACTERISTICS (Circuit of Figure 2)

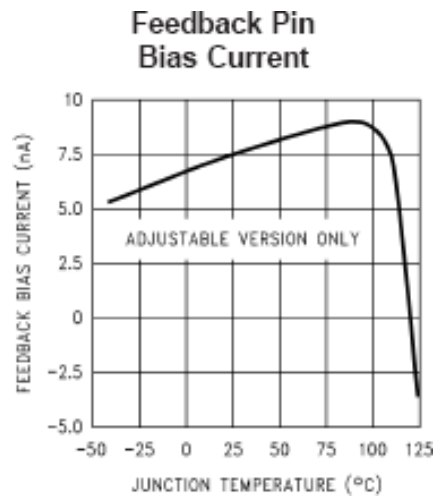

### Continuous Mode Switching Waveforms

$V_{IN} = 20V$ ,  $V_{OUT} = 5V$ ,  $I_{LOAD} = 2A$   
 $L = 32 \mu H$ ,  $C_{OUT} = 220 \mu F$ ,  $C_{OUT} ESR = 50 m\Omega$

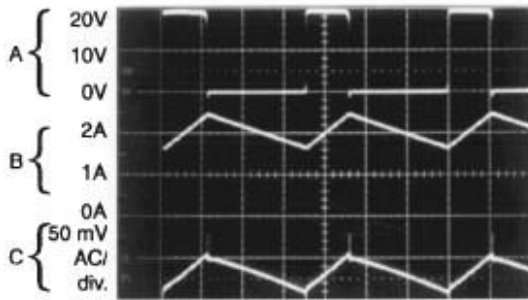

Horizontal Time Base: 2  $\mu s$ /div.

- A: Output Pin Voltage, 10V/div.
- B: Inductor Current 1A/div.
- C: Output Ripple Voltage, 50 mV/div.

### Discontinuous Mode Switching Waveforms

$V_{IN} = 20V$ ,  $V_{OUT} = 5V$ ,  $I_{LOAD} = 500 mA$   
 $L = 10 \mu H$ ,  $C_{OUT} = 330 \mu F$ ,  $C_{OUT} ESR = 45 m\Omega$

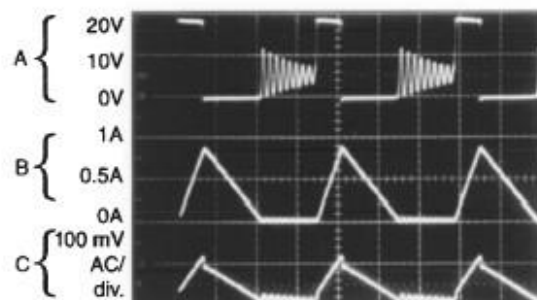

Horizontal Time Base: 2  $\mu s$ /div.

- A: Output Pin Voltage, 10V/div.
- B: Inductor Current 0.5A/div.
- C: Output Ripple Voltage, 100 mV/div.

### Load Transient Response for Continuous Mode

$V_{IN} = 20V$ ,  $V_{OUT} = 5V$ ,  $I_{LOAD} = 500 mA$  to  $2A$   
 $L = 32 \mu H$ ,  $C_{OUT} = 220 \mu F$ ,  $C_{OUT} ESR = 50 m\Omega$

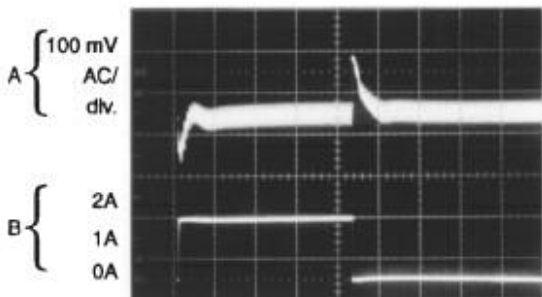

Horizontal Time Base: 100  $\mu s$ /div.

- A: Output Voltage, 100 mV/div. (AC)
- B: 500 mA to 2A Load Pulse

### Load Transient Response for Discontinuous Mode

$V_{IN} = 20V$ ,  $V_{OUT} = 5V$ ,  $I_{LOAD} = 500 mA$  to  $2A$   
 $L = 10 \mu H$ ,  $C_{OUT} = 330 \mu F$ ,  $C_{OUT} ESR = 45 m\Omega$

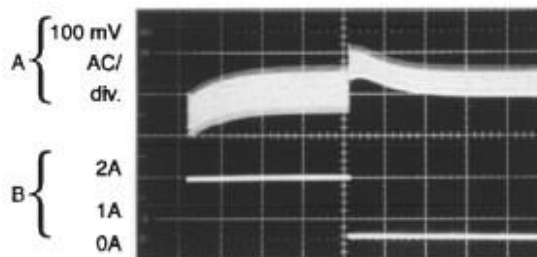

Horizontal Time Base: 200  $\mu s$ /div.

- A: Output Voltage, 100 mV/div. (AC)
- B: 500 mA to 2A Load Pulse

## Test Circuit and Layout Guidelines

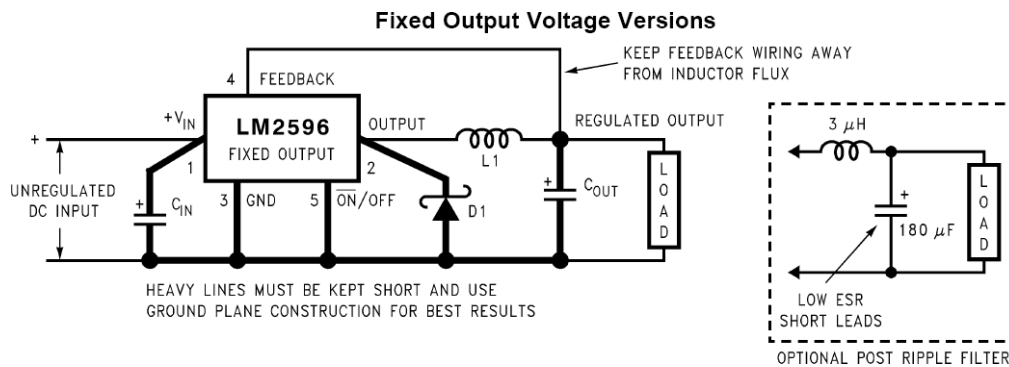

$C_{IN} = 470\mu\text{F}$ , 50V,  $C_{OUT} = 220\mu\text{F}$ , 25V (Aluminum Electrolytic Nichicon "PL Series")

D1 = 5A, 40V Schottky Rectifier, IN5825

L1 = 68uH, L38

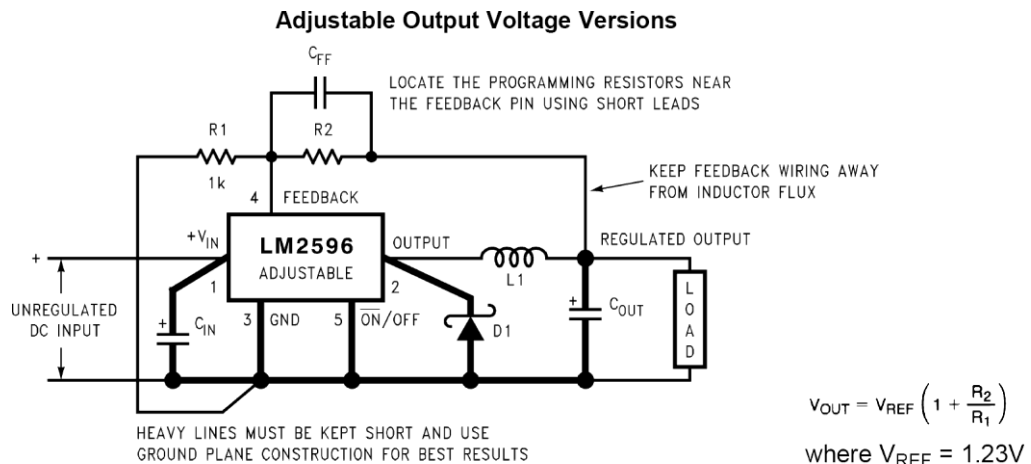

$$V_{OUT} = V_{REF} \left( 1 + \frac{R_2}{R_1} \right)$$

where  $V_{REF} = 1.23\text{V}$

$C_{in} = 470\mu\text{F}$ , 50V,  $C_{out} = 220\mu\text{F}$ , 35V (Aluminum Electrolytic Nichicon "PL Series")

D1 = 5A, 40V Schottky Rectifier, IN5825

L1 = 68uH, R1 = 1 kΩ, 1%, R2 = R1 x (Vout / Vref - 1)

As in any switching regulator, layout is very important. Rapidly switching currents associated with wiring inductance can generate voltage transients which can cause problems. For minimal inductance and ground loops, the wires indicated by heavy lines should be wide printed circuit traces and should be kept as short as possible. For best results, external components should be located as close to the switching IC as possible using ground plane construction or single point grounding. If open core inductors are used, special care must be taken as to the location and positioning of this type of inductor. Allowing the inductor flux to intersect sensitive feedback, IC ground path and COUT wiring can cause problems. When using the adjustable version, special care must be taken as to the location of the feedback resistors and the associated wiring. Physically locate both resistors near the IC, and route the wiring away from the inductor, especially an open core type of inductor.

### REVISION NOTICE

The description in this datasheet is subject to change without any notice to describe its electrical characteristics properly.